

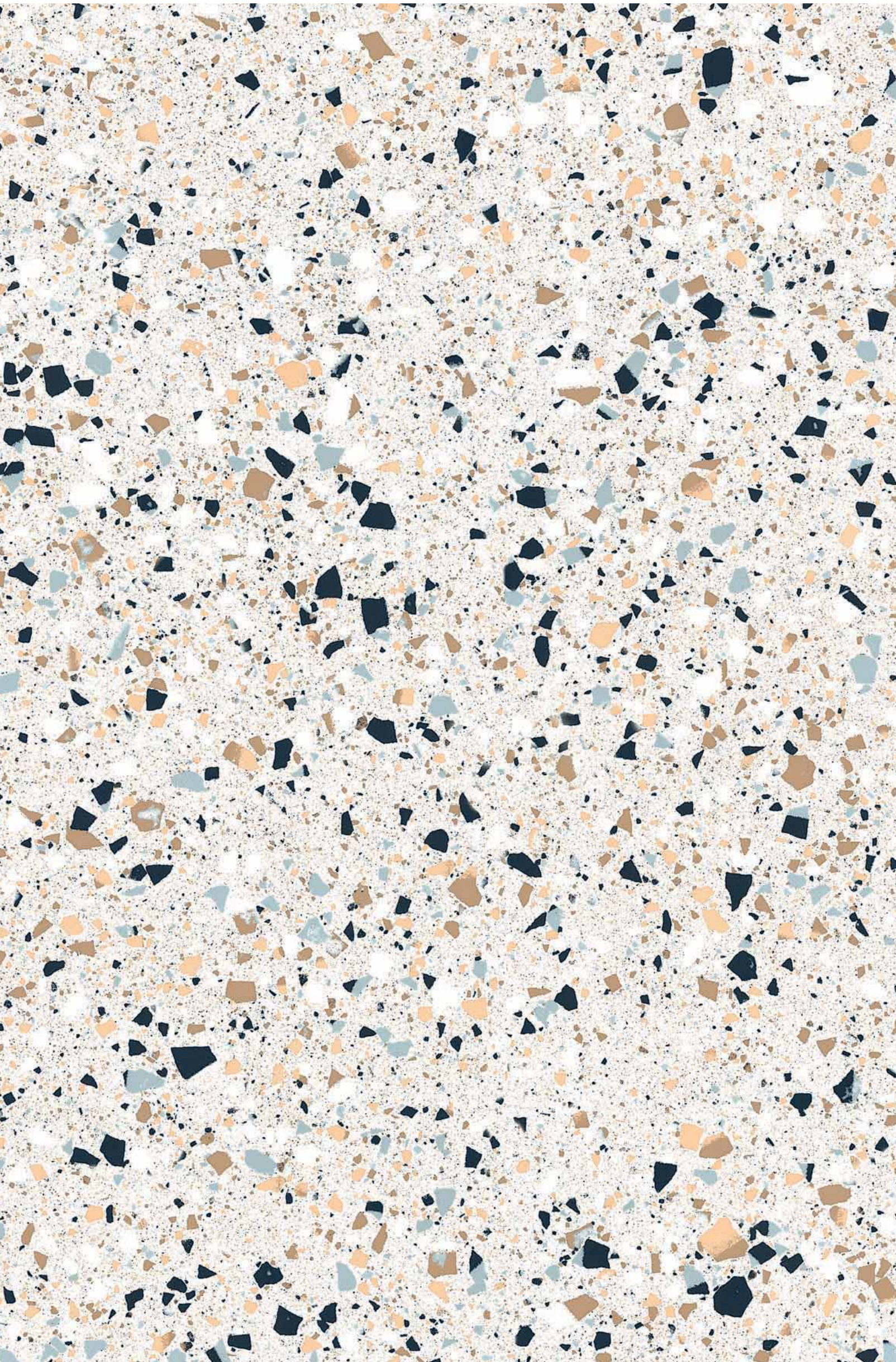

NIGHT COLLECTION

HAND MADE IN ITALY SINCE 1990

BEDSTORIES



BedStories...  
un successo che continua  
nel tempo.

La storia dei letti Felis è il racconto di un'esperienza che attraversa i decenni e di una ricerca stilistica che interpreta il letto in modo creativo e contemporaneo, senza dimenticare il fascino della tradizione. Tutto questo con una cura artigianale per ogni dettaglio ed un'eleganza che non rinuncia alla funzionalità.

Dai rivestimenti sfoderabili, alle testiere rifinite su entrambi i lati, ai meccanismi brevettati, i letti Felis si distinguono per la comodità e l'intelligenza delle soluzioni.

BedStories...  
un succès qui continue  
au fil du temps. L'histoire  
des lits Felis est le récit  
d'une expérience qui  
continue à travers les  
années et d'une recherche  
de style qui interprète le  
lit de manière créative et  
contemporaine, sans oublier  
le charme de la tradition.  
Tout cela avec un soin  
artisanal pour le moindre  
détail et une élégance  
qui ne renonce pas à la  
fonctionnalité.

Des revêtements  
déhoussables, aux têtes de  
lits finies sur les deux côtés,  
aux mécanismes brevetés,  
les lits Felis se distinguent  
pour leur confort et  
l'intelligence des solutions.

BedStories...  
success over time.  
The story of Felis beds is a  
story spanning decades and  
one of a quest to explore  
stylish beds in a creative  
and contemporary way,  
without forgetting the pull  
of tradition. It is a tale of  
an artisan's eye for even  
the finest detail; elegant,  
without compromising on  
practicality. From removable  
covers and headboards  
finished on both sides to  
patented mechanisms, beds  
by Felis stand out for their  
comfort and smart solutions.



1990 YEARS 2020

BedStories...  
Ein bereits lang andauernder  
Erfolg.  
Die Geschichte der  
Felis-Bettmodelle ist  
die Geschichte einer  
jahrzehntelangen Erfahrung  
und von Stilrecherchen, die  
das Bett auf eine kreative  
und zeitgemäße Art und  
Weise zu interpretieren  
wussten, ohne dabei den  
Charme der Tradition zu  
vergessen.

All dies erfolgt mit  
handwerklicher Sorgfalt bis  
ins Detail und einer Eleganz,  
bei der die Zweckmäßigkeit  
nicht zu kurz kommt.  
Von den abnehmbaren  
Bezügen über die beidseitig  
fertiggestellten Kopfteile  
bis hin zu den patentierten  
Mechanismen: Betten von  
Felis zeichnen sich durch  
Komfort und intelligente  
Lösungen aus.

# LA QUALITÀ E IL COMFORT DELL'ECCELLENZA ITALIANA

Da oltre 30 anni in Felis si incontrano la tradizione dei più alti saperi artigiani e la costante ricerca dell'innovazione. La nostra è una storia di specialisti, legata in modo esclusivo agli imbottiti di qualità. Una scelta rigorosa, che ci permette di offrirvi un'ampia gamma di divani, divani letto e letti, curati nel design e duraturi nel tempo. Una vera oasi di benessere.

## THE QUALITY AND COMFORT OF THE ITALIAN EXCELLENCE

At Felis for over 30 years the tradition of the finest craftsmen's skill has gone hand in hand with constant research into innovation. Our story is one of specialists associated exclusively with high quality upholstery products. This rigorous choice enables us to offer you a wide range of meticulously designed sofas, sofa beds and beds that last over time. A true haven of well-being.



**Nasce nel 2020 il nuovo stabilimento di oltre 35.000 mq dotato delle migliori tecnologie disponibili applicabili all'imbottito, con 2.000 mq di showroom aperto al pubblico.**

The new factory was founded in 2020 and with its 35.000 sqm is equipped with the best available technologies applying to padded beds and a showroom of 2.000 sqm open to public.

Le nouvel établissement de plus de 35.000 m<sup>2</sup> naît en 2020, doté des meilleures technologies disponibles des rembourrés, et avec 2000 m<sup>2</sup> de salle d'exposition ouverte au public.

Das neue Werk mit einer Fläche von 35.000 m<sup>2</sup> wurde 2020 eröffnet; es ist mit den besten, für Polstermöbel erhältlichen Technologien ausgestattet und beinhaltet einen 2.000 m<sup>2</sup> großen Ausstellungsbereich, der auch der Öffentlichkeit zugänglich ist.

## LA QUALITÉ ET LE CONFORT DE L'EXCELLENCE ITALIENNE

Depuis plus de 30 ans chez Felis vous rencontrez la tradition des plus savants artisans et la recherche d'innovation constante. Notre histoire est une histoire de spécialistes, liée de façon exclusive aux rembourrés de qualité. Un choix rigoureux qui nous permet de vous offrir une ample gamme de divans lit et de lits, soignés dans le design et durables dans le temps. Une vraie oasis de bien-être.



## DIE QUALITÄT UND DER KOMFORT ITALIENISCHER SPITZENLEISTUNG

Seit mehr als 30 Jahren verbindet Felis die Tradition hochwertiger Handwerkskunst mit ständigem Streben nach Innovation. Unsere Unternehmensgeschichte ist die eines Spezialisten, denn wir beschäftigen uns ausschließlich mit Qualitätspolstermöbeln. Eine konsequente Entscheidung, die es uns ermöglicht, ein umfassendes Sortiment Sofas, Schlafsofas und Betten anzubieten, die sorgfältig entworfen wurden und lange halten. Eine wahre Oase des Wohlbefindens.

# INDEX



Indice alfabetico  
 alphabetical index  
 index alphabétique  
 Alphabetisches Inhaltsverzeichnis

336	<b>Adrian</b>	346	Tech. info.
148	<b>Allen</b>	156	Tech. info.
388	<b>Arley - A/B</b>	396	Tech. info.
530	<b>Boiserie</b>		
200	<b>Bowie</b>	226	Tech. info.
412	<b>Charles</b>	422	Tech. info.
376	<b>Chris</b>	384	Tech. info.
358	<b>Clyde</b>	366	Tech. info.
464	<b>Damian</b>	474	Tech. info.
326	<b>Dennis</b>	334	Tech. info.
240	<b>Demy</b>	248	Tech. info.
158	<b>Edgar</b>	166	Tech. info.
52	<b>Elle</b>	66	Tech. info.
178	<b>Emily</b>	186	Tech. info.
520	<b>Erik</b>	527	Tech. info.
80	<b>Foster</b>	88	Tech. info.
70	<b>Gaber</b>	78	Tech. info.
168	<b>George</b>	176	Tech. info.
318	<b>Hamilton</b>	324	Tech. info.
140	<b>Henry</b>	146	Tech. info.
476	<b>Jason</b>	484	Tech. info.
348	<b>Julius</b>	356	Tech. info.
308	<b>Karl</b>	316	Tech. info.
260	<b>Kevin</b>	272	Tech. info.
300	<b>Lenny</b>	306	Tech. info.
112	<b>Luis</b>	120	Tech. info.
250	<b>Megan</b>	258	Tech. info.
434	<b>Miller</b>	442	Tech. info.
34	<b>Moonlight</b>	50	Tech. info.
228	<b>Murphy</b>	238	Tech. info.
188	<b>Oliver</b>	196	Tech. info.
454	<b>Oscar</b>	462	Tech. info.
100	<b>Paris</b>	108	Tech. info.
368	<b>Parker</b>	374	Tech. info.
534	<b>Panquette Collection</b>	535	Tech. info.
274	<b>Penny</b>	284	Tech. info.
424	<b>Rick</b>	432	Tech. info.
122	<b>Scotty / S. Compact</b>	136	Tech. info.
488	<b>Sommier Collection</b>		
490	<b>Sommy Big / Small</b>	496	Tech. info.
498	<b>Sommy Star / Moon</b>	506	Tech. info.
508	<b>Sommy Sky / Ocean</b>	518	Tech. info.
90	<b>Spencer</b>	98	Tech. info.
12	<b>Taipei</b>	32	Tech. info.
398	<b>Tim - A/B</b>	410	Tech. info.
286	<b>Tiffany</b>	298	Tech. info.
446	<b>Vern</b>	452	Tech. info.

## Air Collection



**Taipei**  
12 Tech. info. 32



**Moonlight**  
34 Tech. info. 50



**Elle**  
52 Tech. info. 66

## Hug Collection



**Gaber**  
70 Tech. info. 78



**Foster**  
80 Tech. info. 88



**Spencer**  
90 Tech. info. 98



**Paris**  
100 Tech. info. 108

## Relax Collection



**Luis**  
112 Tech. info. 120



**Scotty / S.Compact**  
122 Tech. info. 136



**Henry**  
140 Tech. info. 146



**Allen**  
148 Tech. info. 156



**Edgar**  
158 Tech. info. 166



**George**  
168 Tech. info. 176



**Emily**  
178 Tech. info. 186



**Oliver**  
188 Tech. info. 196

## Timeless Collection



**Bowie**  
200 Tech. info. 226



**Murphy**  
228 Tech. info. 238



**Demy**  
240 Tech. info. 248



**Megan**  
250 Tech. info. 258



**Kevin**  
260 Tech. info. 272



**Penny**  
274 Tech. info. 284



**Tiffany**  
286 Tech. info. 298



**Lenny**  
300 Tech. info. 306



**Karl**  
308 Tech. info. 316



**Hamilton**  
318 Tech. info. 324



**Dennis**  
326 Tech. info. 334



**Adrian**  
336 Tech. info. 346



**Julius**  
348 Tech. info. 356



**Clyde**  
358 Tech. info. 366



**Parker**  
368 Tech. info. 374



**Chris**  
376 Tech. info. 384

## Easy Collection



**Arley - A/B**  
388 Tech. info. 396



**Tim- A/B**  
398 Tech. info. 410



**Charles**  
412 Tech. info. 422



**Rick**  
424 Tech. info. 432



**Miller**  
434 Tech. info. 442

## Classic Collection



**Vern**  
446 Tech. info. 452



**Oscar**  
454 Tech. info. 462



**Damian**  
464 Tech. info. 474



**Jason**  
476 Tech. info. 484

## Contract / Home Solution



**Sommier Collection**  
488



**Erik**  
520 Tech. info. 527



**Boiserie Collection**  
530



**Panquette Collection**  
534 Tech. info. 535

## Optional / Info. Tech.

- 540 **Sacca porta oggetti** / Storage bag / Sac porte-objets / Einstecktasche
- 541 **Illuminazione** / Lighting / Éclairage / Beleuchtung
- 542 **Portagioie** / Jewelry box / Porte-bijoux / Schmuckkästchen
- 543 **Relax System**
- 543 **USB**
- 544 **Piedi** / Feet / Pides / Füße
- 547 **Reti** / Supports / Sommier / Bettenroste
- 550 **Meccanismi** / Mechanisms / Mécanismes / Mechanismen
- 552 **Contenitore nel ring** / Container inside the ring / Rangement dans le ring / Bettkasten im Bettgestell
- 552 **Sacca contenitore** / Bag container / Sac coffre de rangement / Aufbewahrungstasche
- 553 **Coprirete** / Support cover / Couvre-sommier / Bettenrostaufgabe
- 554 **Tavolino** / Table / Table basse / Couch-/Beistellfisch
- 555 **Cuscino per tavolino** / Table seat cushion / Coussin pour table basse / Kissen für Couch-/Beistellfisch
- 556 **Clean up System**
- 557 **Sempre l'altezza giusta** / Always the right height / Toujours la bonne hauteur / Immer die richtige Höhe

# Air Collection

Aria, l'idea stessa di leggerezza e di respiro. È il nuovo programma di letti Felis, l'incipit di una collezione che si arricchirà nel tempo di nuovi modelli. Il design leggero e di tendenza, caratterizzato dal ring sottile e un raffinato minimalismo, non rinuncia alla solidità della struttura. Air Collection è disponibile sia nella versione con alti piedini sia in quella con doppia barra, per provare l'emozione di dormire sospesi nell'aria.

Air, the very idea of lightness and breath. It's the new bedding program of Felis, the beginning of a collection which over time will be enriched with new models. Lightness for a trendy design defined by high feet, a slim ring and an elegant minimalism in a solid structure. And breath: the ideal place where to indulge, finally, to moments of well-deserved rest.

Air, l'idée même de légèreté et de souffle. C'est le nouveau programme de lits Felis, l'incipit d'une collection qui s'enrichira, avec le temps, grâce à de nouveaux modèles. Légèreté: pour le design de tendance, caractérisé par des pieds hauts, cadre fin et un minimalisme raffiné qui ne renonce de toute façon pas à la solidité de la structure. Et souffle: lieu idéal dans lequel s'abandonner, finalement, à des moments de relax bien mérité.

Aria, steht - wie der Name schon sagt - für Leichtigkeit und einen Moment des Aufatmens. Dies ist das neue Bettenprogramm von Felis, und der Beginn einer Kollektion, die im Lauf der Zeit um neue Modelle erweitert wird. Leichtigkeit: für das trendige Design, das sich durch hohe Füße, ein schmales Bettgestell und raffinierten Minimalismus auszeichnet, ohne auf eine solide Struktur zu verzichten. Und ein Moment des Aufatmens: der ideale Ort, um sich endlich einmal wohlverdienter Entspannung hinzugeben.

# Taipei



Richiami d'oriente: nel design della testiera ispirato all'iconico grattacielo taiwanese Taipei 101 e nel legno fresato che evoca il bambù. Su Taipei è facile abbandonarsi a sogni lontani.

Oriental hints in the headboard design inspired by the iconic Taiwanese skyscraper Taipei 101 and in the milled wood evoking bamboo. On Taipei it is easy to indulge to far dreams.

Rappels d'Orient: dans le design de la tête de lit inspiré au gratte-ciel iconique taiwanais Taipei 101 et dans le bois fraisé qui évoque le bambou. Avec Taipei il est facile de s'abandonner aux rêves lointains.

Ein Hauch Orient: durch das Design des Kopfteils, das am ikonischen taiwanesischen Wolkenkratzer Taipei 101 inspiriert ist, und das gefräste Holz, das an Bambus erinnert. Auf Taipei können Sie sich problemlos fernen Träumen hingeben.









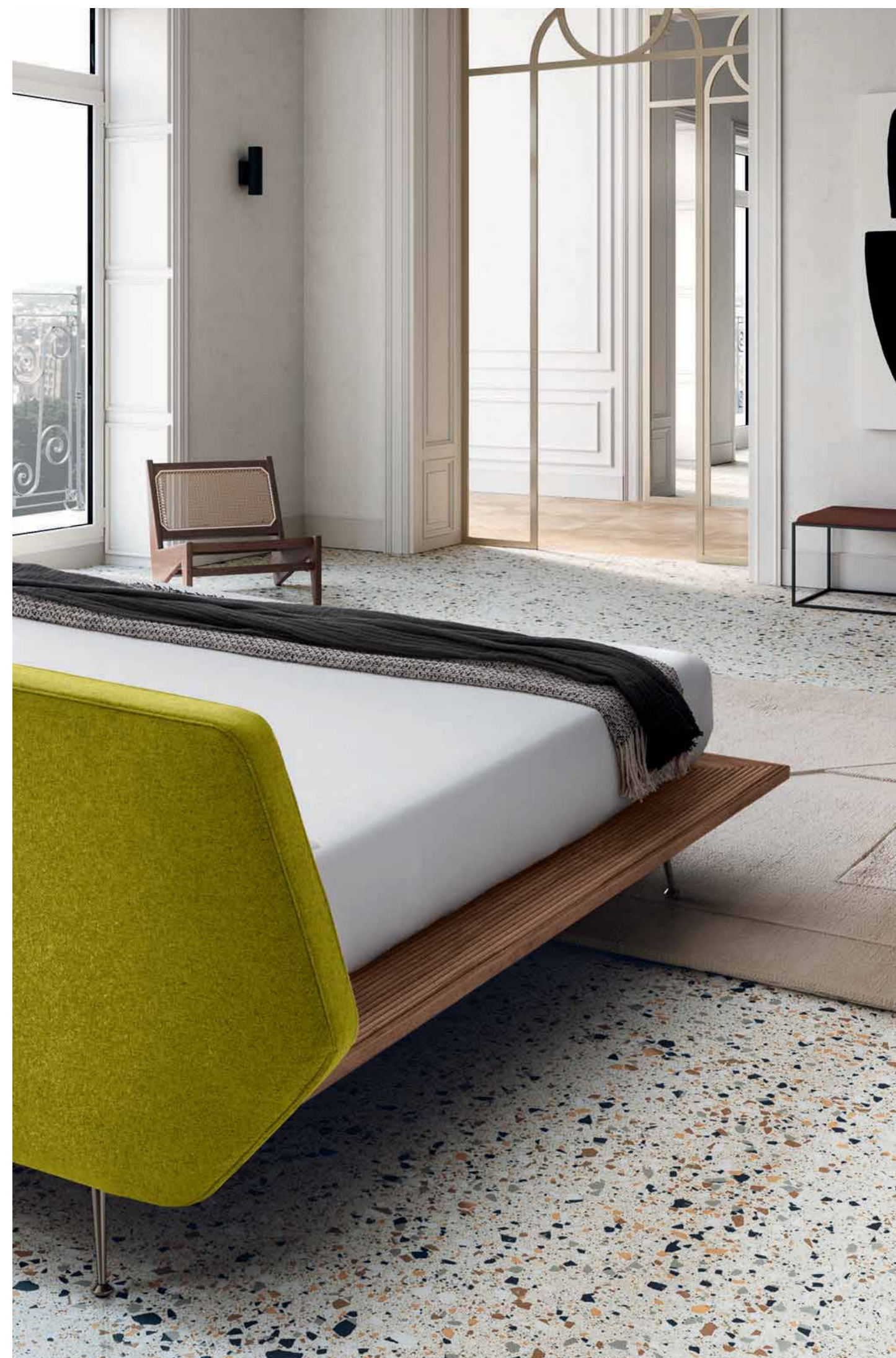

Taipei nasce da una ricerca di essenzialità, a vantaggio di materiali il più possibile naturali. Il pianale in legno multistrato, tutto a vista, è trattato ad acqua e oli naturali.

Taipei comes from a research of simplicity favouring materials as natural as possible. The visible plywood bed plan is water and natural oils treated.

Taipei nait suite à la recherche de l'essentiel, au profit de matériaux les plus naturels possibles. Le pourtour en bois multicouches, totalement à vue, est traité à l'eau et aux huiles essentielles.

Taipeh entspringt dem Streben nach Wesentlichkeit und dem Wunsch einer Verwendung möglichst natürlicher Materialien. Die sichtbare Liegefläche aus Mehrschichtholz wurde mit Wasser und natürlichen Ölen behandelt.



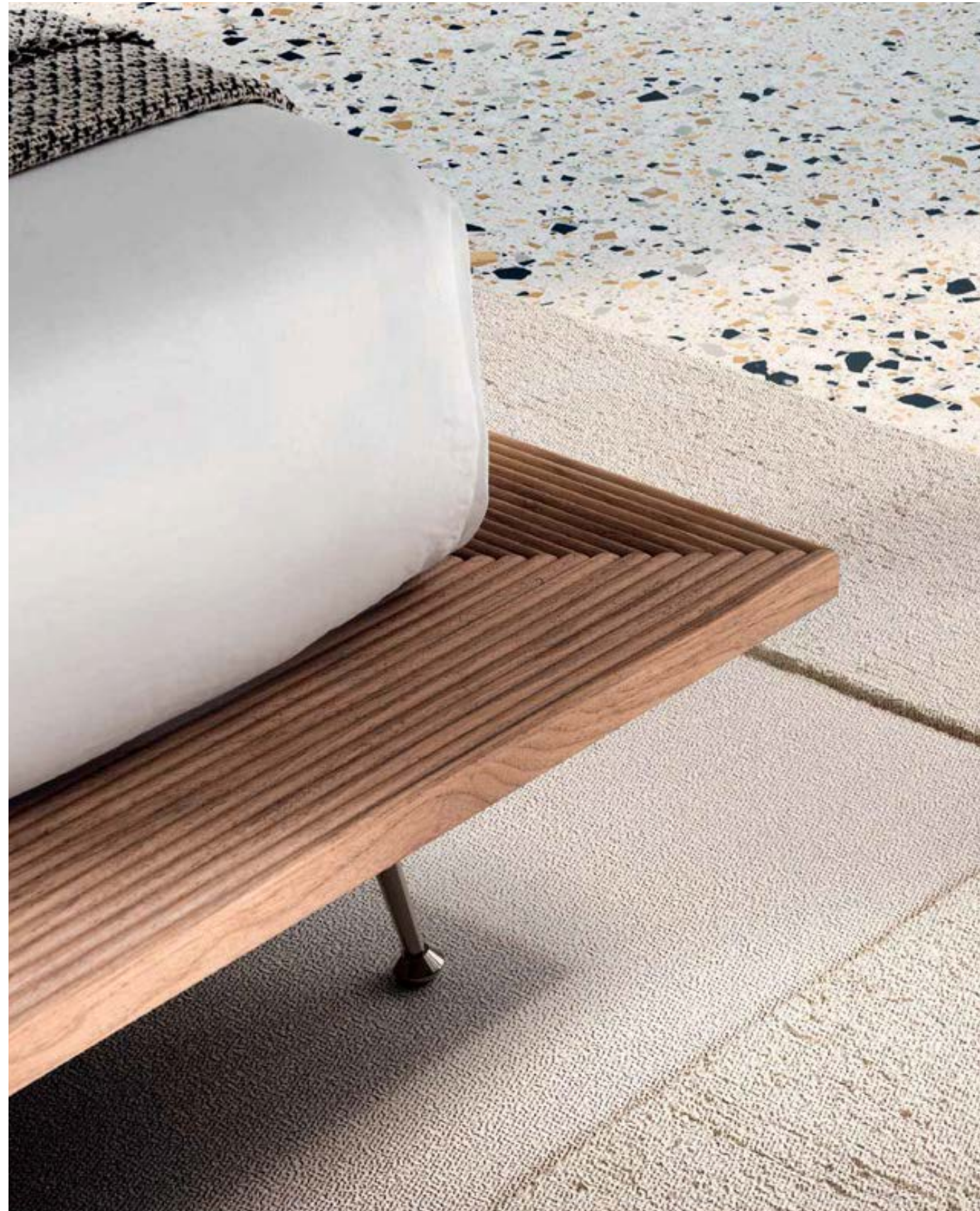

Il ring in noce canaletto è dedicato agli amanti del legno. Con le sue fessature ricrea un effetto bambù che accentua le note orientali del modello.

The ring in canaletto walnut is dedicated to wood lovers. Its grooves recreate a bamboo effect emphasizing the oriental notes of the model.

Le cadre en noyer canaletto est voué aux amants du bois. Par ses fraisages il recrée un effet bambou qui accentue les notes orientales de ce modèle.

Das Bettgestell aus Canaletto Nussbaum ist allen Holzliebhabern gewidmet. Mit seinen Fräsarbeiten erzeugt das Bett einen Bambus-Effekt, der die orientalische Note des Modells unterstreicht.

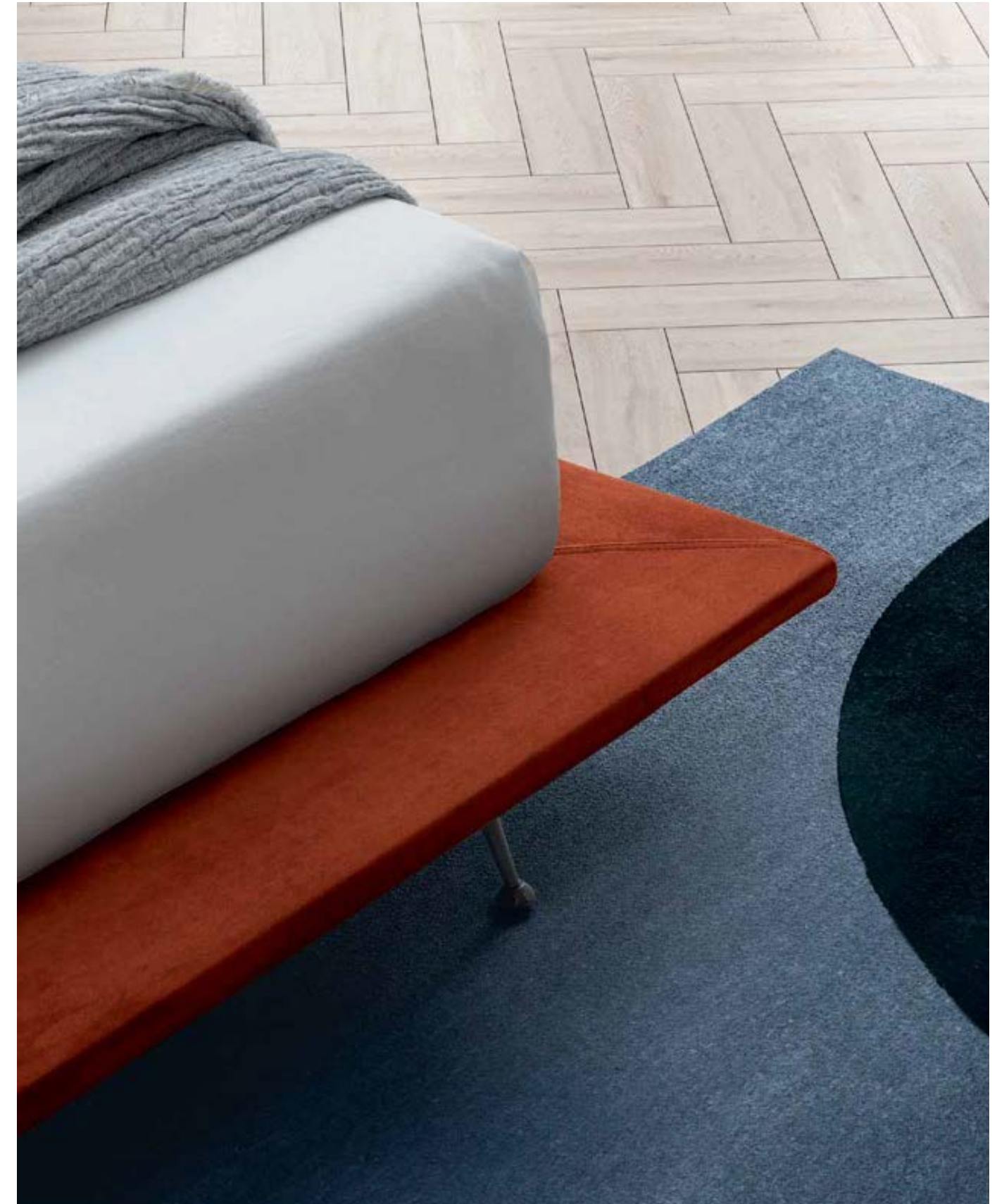

A chi invece preferisce la versione con ring imbottito, Taipei offre la possibilità di scegliere tra le innumerevoli varianti di tessuto Felis.

For those who instead prefer the version with padded ring, Taipei offers a choice among the countless Felis fabric options.

A ceux qui au contraire préfèrent la version avec cadre rembourré, Taipei offre la possibilité de choisir entre de nombreuses variantes de tissu Felis.

All diejenigen, die die gepolsterte Bettgestellversion bevorzugen, können für Taipei einen der zahlreichen Felis-Stoffe wählen.



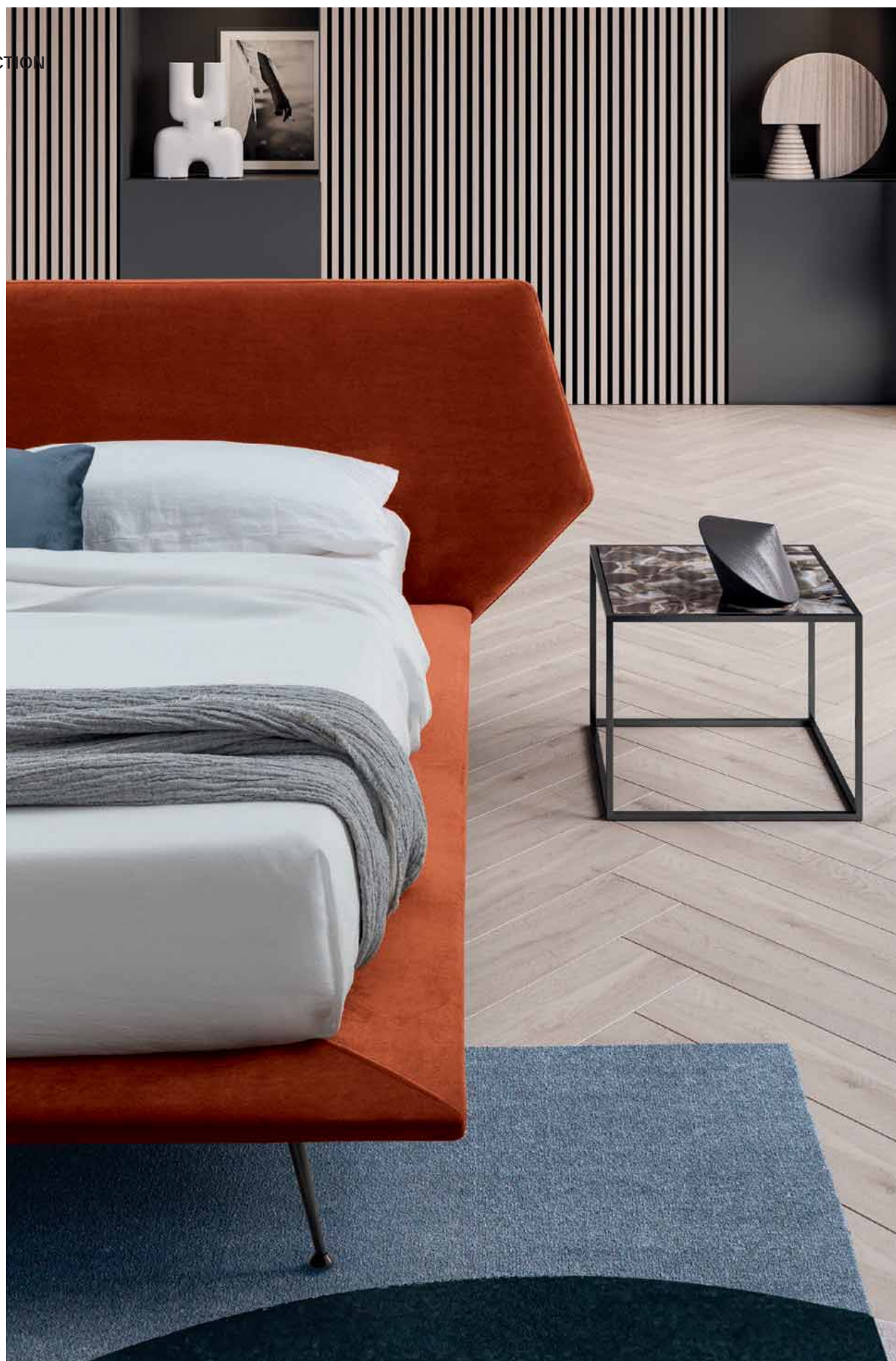

Nel loro particolare disegno, i piedini si ispirano alla forma della sezione del bambù e sono disponibili in quattro varianti colore: ottone, carbon look, rame e cromo.

The particular design of the feet is inspired by the form of the bamboo section and are available in four color variants: brass, carbon look, copper and chrome.

Avec leur design particulier, les petits pieds s'inspirent à la forme de la section du bambou et sont disponibles en quatre variantes de couleur: laiton, look carbone, cuivre et chrome.

Die Füße sind an der Form des Bambusprofils inspiriert und in vier Farbvarianten erhältlich: Messing, Carbon Look, Kupfer und Chrom.



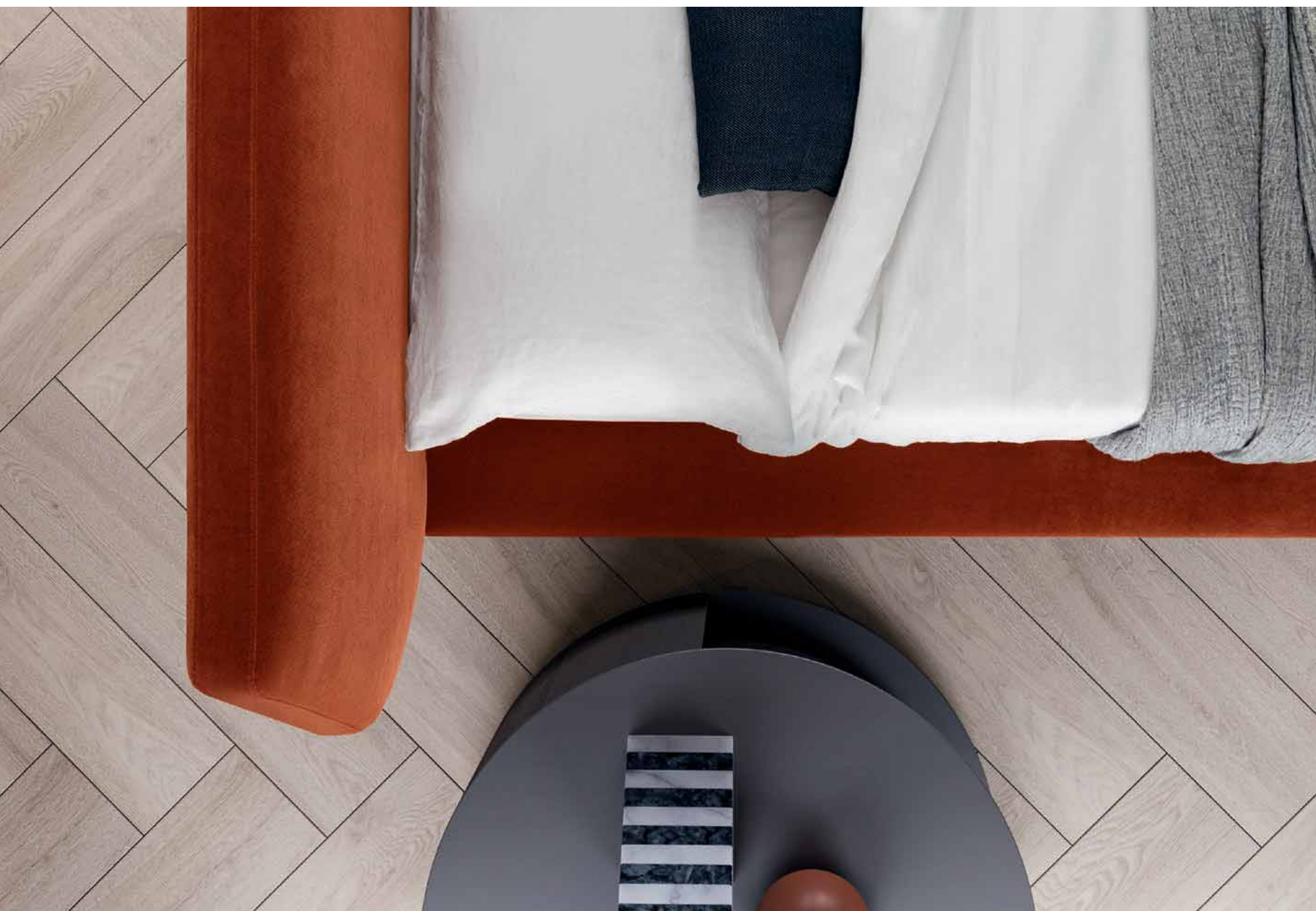

La testiera, così come il ring nella variante tessuto, è completamente sfoderabile per garantire sempre massima funzionalità e igiene.

The headboard and the bedframe in the fabric version have covers fully removable to provide always the best functionality and hygiene.

La tête de lit, ainsi comme le cadre dans la version tissu, est complètement déhoussable afin de garantir toujours la plus grande fonctionnalité et hygiène.

Das Kopfteil ist - wie das Bettgestell in der Stoffversion - komplett abziehbar, damit immer maximale Zweckmäßigkeit und Hygiene gewährleistet ist.





**CLOUD SYSTEM: LEGGERO COME UNA NUVOLOLA / CLOUD SYSTEM: AS LIGHT AS A CLOUD**  
 / SYSTÈME CLOUD : LÉGER COMME UN NUAGE / CLOUD SYSTEM: SO LEICHT WIE EINE WOLKE



Tutti abbiamo sognato almeno una volta di dormire su una nuvola. Grazie al sistema di barre Cloud System, il letto appare sospeso e offre la sensazione di fluttuare leggeri nell'aria.

Nous avons tous rêvé au moins une fois de dormir sur un nuage. Grâce au système de barres du Système Cloud, le lit semble suspendu et offre la sensation de fluctuer légers dans l'air.

We all dreamed just once to sleep on a cloud. By the bar system Cloud System, the bed appears to be suspended and gives you the feeling you are floating in mid air.

Wir alle haben schon einmal davon geträumt, auf einer Wolke zu schlafen. Dank des mit Stangen arbeitenden Cloud Systems scheint das Bett zu schweben und suggeriert das Gefühl, leicht in der Luft zu gleiten.

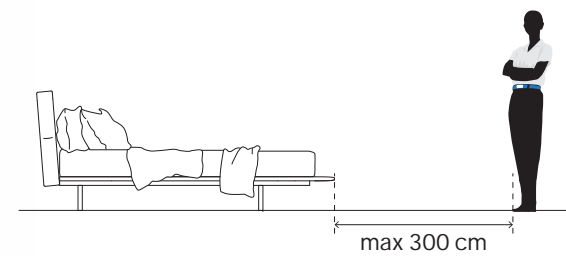

**RING CON TECNOLOGIA ANTISHOCK / BEDFRAME WITH ANTISHOCK TECHNOLOGY**  
 / CADRE DE LIT AVEC TECHNOLOGIE ANTI SHOCK / BETTGESTELL MIT ANTIAUFPRALL-TECHNOLOGIE

L'imbottitura del ring è realizzata con una gomma a elevata densità che consente di attutire eventuali occasioni di impatto con il telaio. Una protezione para-colpi studiata per massimizzare nello stesso tempo sicurezza e piacere estetico.

Le rembourrage du cadre est réalisé avec une gomme à haute densité qui permet d'amortir d'éventuels impacts avec la structure. Une protection tour de lit étudiée afin d'augmenter également sécurité et plaisir esthétique.

The ring padding is made of a high density rubber allowing to cushion any impacts with the frame. A shock absorber protection developed to maximize at the same time safety and aesthetic pleasure.

Die Polsterung des Bettgestells besteht aus hochdichtem Gummi, das jeden Aufprall auf den Rahmen abfedert. Ein Stoßschutz, der angenehm anzusehen ist und auch für mehr Sicherheit sorgt.

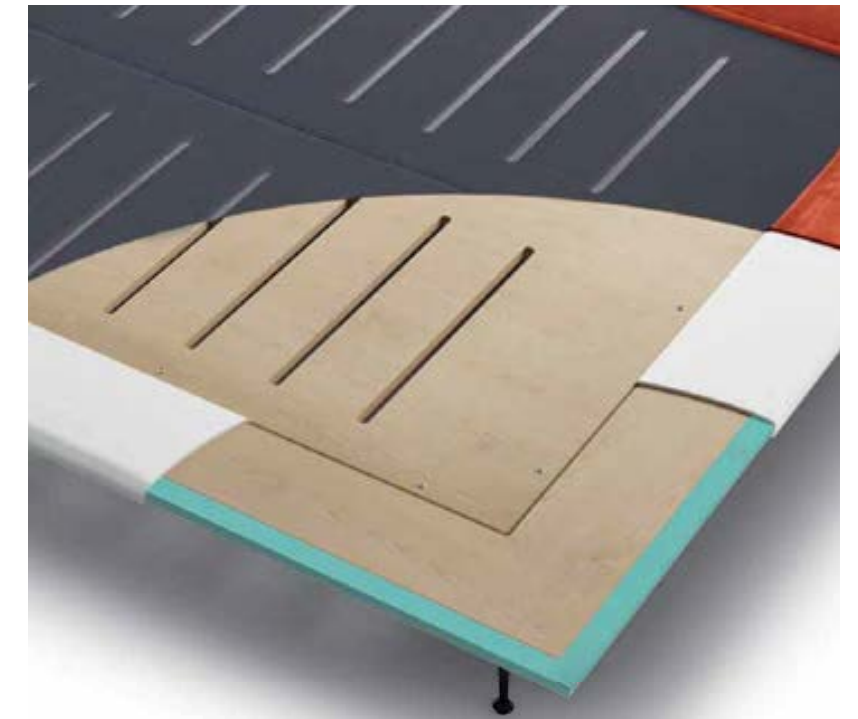

# Taipei

COMPLETAMENTE SFODERABILE / COMPLETELY REMOVABLE FABRIC / COMPLÈTEMENT DÉHOUSSABLE / VOLLSTÄNDIG ABZIEHBAR

## TESTIERA

**TELAIO** in multistrato di legno di pioppo in classe E1 da 18 mm a bassa emissione di formaldeide e fibra di legno naturale.

**ESPANSI** di poliuretano indeformabile a portanza differenziata. Olmosoft 22 / D40 rivestito con falda termolegata da 300g/mq.

**PRIMO RIVESTIMENTO** in resinato 200 gr. poliestere accoppiato a vellutino in maglina.

## PANNELLI

**TELAIO** in multistrato di legno di pioppo in classe E1 da 20 mm a bassa emissione di formaldeide e fibra di legno naturale.

**PRIMO RIVESTIMENTO** in resinato 200 gr. poliestere accoppiato a vellutino in maglina e tessuto 3D traspirante.

## RETE

Tubolare in metallo a sezione rettangolare verniciata con polveri epossidiche.

## HEADBOARD

Poplar plywood **FRAME** 18 mm in E1 class at low formaldehyde emissions and natural wood fiber.

## POLYURETHANE FOAM

crushproof of different capacity. Olmosoft 22 / D40 covered with staple thermo bonded 300g/mq. **FIRST COVER** in resin fabric 200 gr. polyester bonding knitted light velvet and breathable 3D fabric.

## PANELS

Poplar plywood **FRAME** 20 mm in E1 class at low formaldehyde emissions and natural wood fiber.

**FIRST COVER** in resin fabric 200 gr. polyester bonding knitted light velvet and breathable 3D fabric.

## FRAME

Rectangular cross-section metal tubing, epoxy painted.

## TÊTE DE LIT

**STRUCTURE** en multicouches de peuplier classe E1 de 18 mm à basse émission de formaldéhyde et fibre de bois naturel.

**EXPANSÉS** de polyuréthane indéformable à portance différenciée. Olmosoft 22 / D40 revêtu avec bord thermo-lié de 300 g. /m<sup>2</sup>.

**PREMIER REVÊTEMENT** en résiné 200 gr. polyester accouplé à du velours en maille.

## PANNEAUX

**STRUCTURE** en multicouches de peuplier classe E1 de 20 mm. à basse émission de formaldéhyde et fibre de bois naturel.

**PREMIER REVÊTEMENT** en résiné 200 gr. polyester accouplé à du velours en maille et tissu 3D transpirant.

## SOMMIER

Tubulaire en métal à section rectangulaire verni aux poudres époxydes.

## KOPFTEIL

**RAHMEN** aus Pappelmehrschichtholz mit 18 mm Schichtdicke der Klasse E1, geringer Formaldehydabgabe und natürlichen Holzfasern.

Formbeständiger Polyurethan**SCHAUM** mit differenzierter Tragfähigkeit. Olmosoft 22 / D40 verkleidet mit heiß verbundener Schicht zu 300g/qm.

**ERSTE VERKLEIDUNG** aus 200 g Polyesterharz mit aufkaschiertem Samt.

## PANEELE

**RAHMEN** aus Pappelmehrschichtholz mit 20 mm Schichtdicke der Klasse E1, geringer Formaldehydabgabe und natürlichen Holzfasern.

**ERSTE VERKLEIDUNG** aus 200 g Polyesterharz mit aufkaschiertem Samt und atmungsaktivem 3D-Gewebe.

## BETTENROST

Vierkantrohr mit rechteckigem Querschnitt, mit Epoxidpulver lackiert.

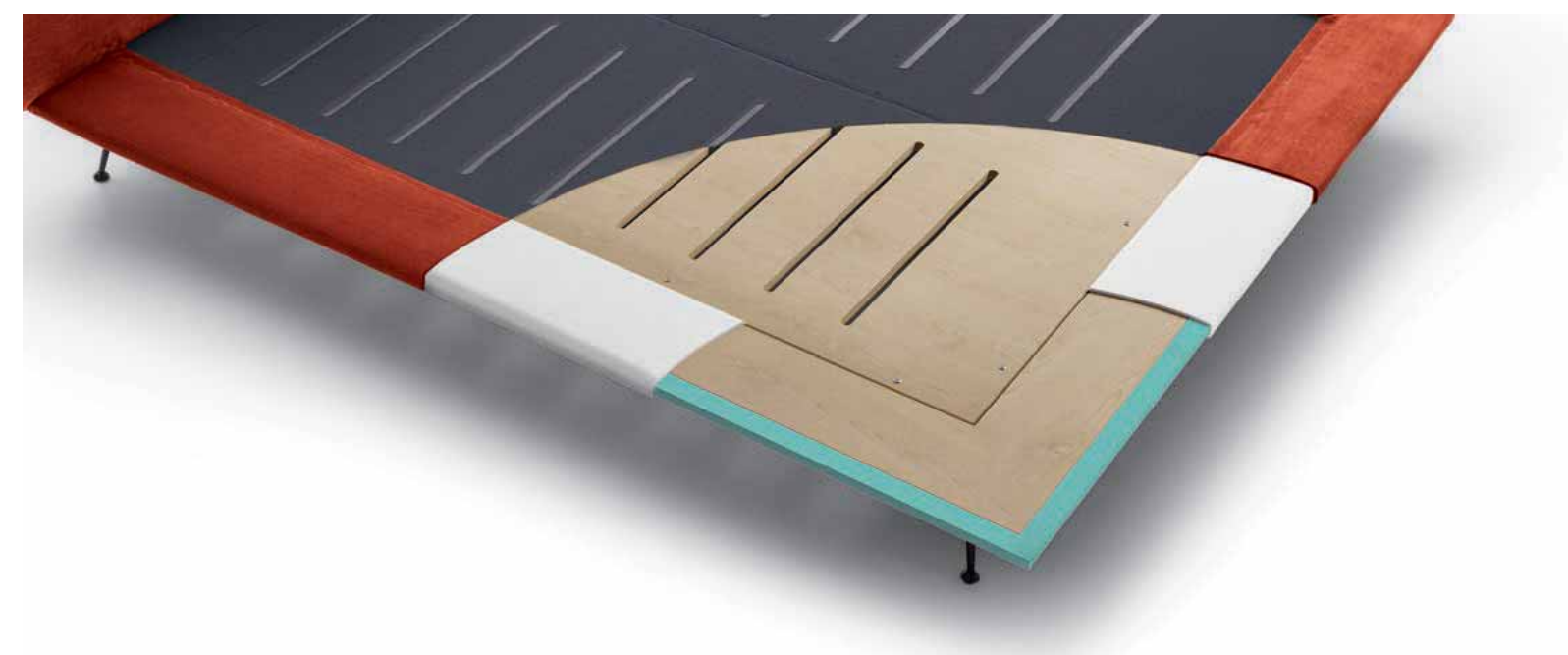

**RING TESSUTO / FABRIC RING**  
/ CADRE TISSU / BETTGESTELL STOFF



**RING LEGNO / WOOD RING**  
/ CADRE BOIS / BETTGESTELL HOLZ



**TESSUTO TRASPIRANTE / BREATHABLE FABRIC**  
/ TISSU TRANSPIRANT / ATMUNGSAKTIVER STOFF

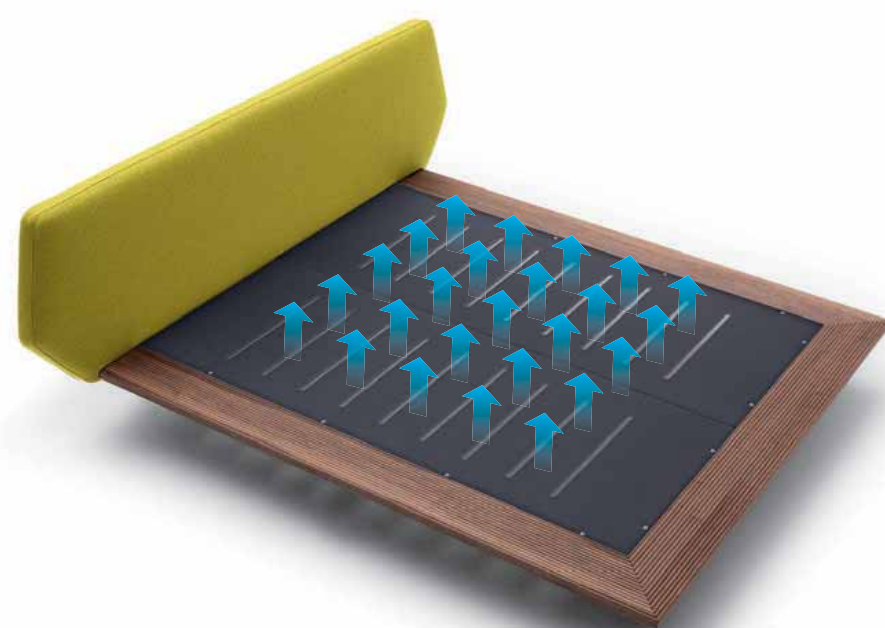

Il tessuto che copre i pannelli è un tessuto 3D antipolvere che lascia però passare l'aria, tenendo il materasso asciutto e pulito.  
The fabric covering the panels is a 3D dustproof textile allowing air through and keeping the mattress dry and clean.  
Le tissu qui couvre les panneaux est un tissu 3D anti-poussière qui laisse passer par contre l'air, en conservant le matelas sec et propre.  
Der Stoff zur Verkleidung der Paneele ist ein vor Staub schützendes 3D-Gewebe, das luftdurchlässig ist und die Matratze trocken und sauber hält.

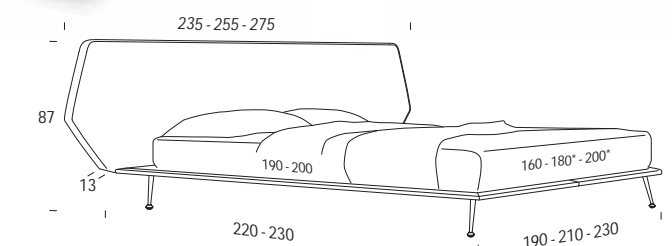

Disponibile con ring in tessuto o legno / Available with fabric or wood ring / Disponible avec cadre en tissu ou bois / Erhältlich mit Bettgestell aus Stoff oder Holz

\* Rete L. 180 e L. 200 cm solo profondità 200 cm / Support W. 180 and W. 200 cm only D 200 cm / Sommier L. 180 et L. 200 cm uniquement en profondeur 200 cm / Attenrost B. 180 und B. 200 cm nur mit Tiefe 200 cm

**PIEDE SIXTY H 21 / Sixty H 21 foot**  
/ Pied Sixty H 21 / Fuss Sixty H 21

Pag 544



Ottone / Brass  
/ Laiton / Messing

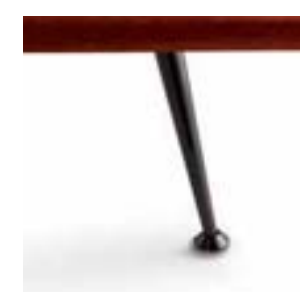

Carbon look

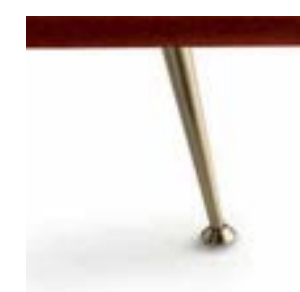

Rame / Copper  
/ Cuivre / Kupfer



Cromo lucido / Shining chrome  
/ Chrome brillant / Chrom Hochglanz

**CLOUD SYSTEM**

Pag 544



Nero opaco / Mat black  
/ Noir mat / Mattschwarz

Disponibile per materasso  
Available for mattress  
Disponible pour matelas  
Verfügbar für Matratze  
L.160-180-200

# Moonlight



Chi ci dorme soltanto non sa cosa si perde. La testiera di Moonlight è un morbido appoggio che accoglie comodamente chiunque voglia concedersi il piacere di un buon libro o della tv a letto.

Those who merely sleep there do not know what they're missing. The Moonlight headboard is a soft and cosy support for the pleasure of a good reading or watching TV in bed.

Qui ne fait qu'y dormir ne sait pas ce qu'il se perd. La tête de lit de Moonlight est un appui souple qui accueille confortablement quiconque veuille s'offrir le plaisir d'un bon livre ou regarder la télévision au lit.

Wer nur darin schläft, weiß nicht, was er verpasst. Das Kopfteil von Moonlight ist wie eine weiche Stütze, die jeden bequem abstützt, der sich im Bett dem Genuss eines guten Buches hingeben oder in Ruhe fernsehen möchte.







Impreziosita da cuciture pizicate e rifinita su entrambi i lati, la generosa testiera gioca in contrasto con il sottile ring.

The wide headboard embellished by pinched stitchings finished on both sides plays in contrast to the thin ring.

Enrichit par des coutures pincées et avec finitions sur les deux côtés, la tête de lit généreuse joue en contraste avec le cadre de lit fin.

Das an beiden Seiten mit Pinched-Nähten aufgepepptte Kopfteil bildet einen schönen Kontrast zum schmalen Bettgestell.

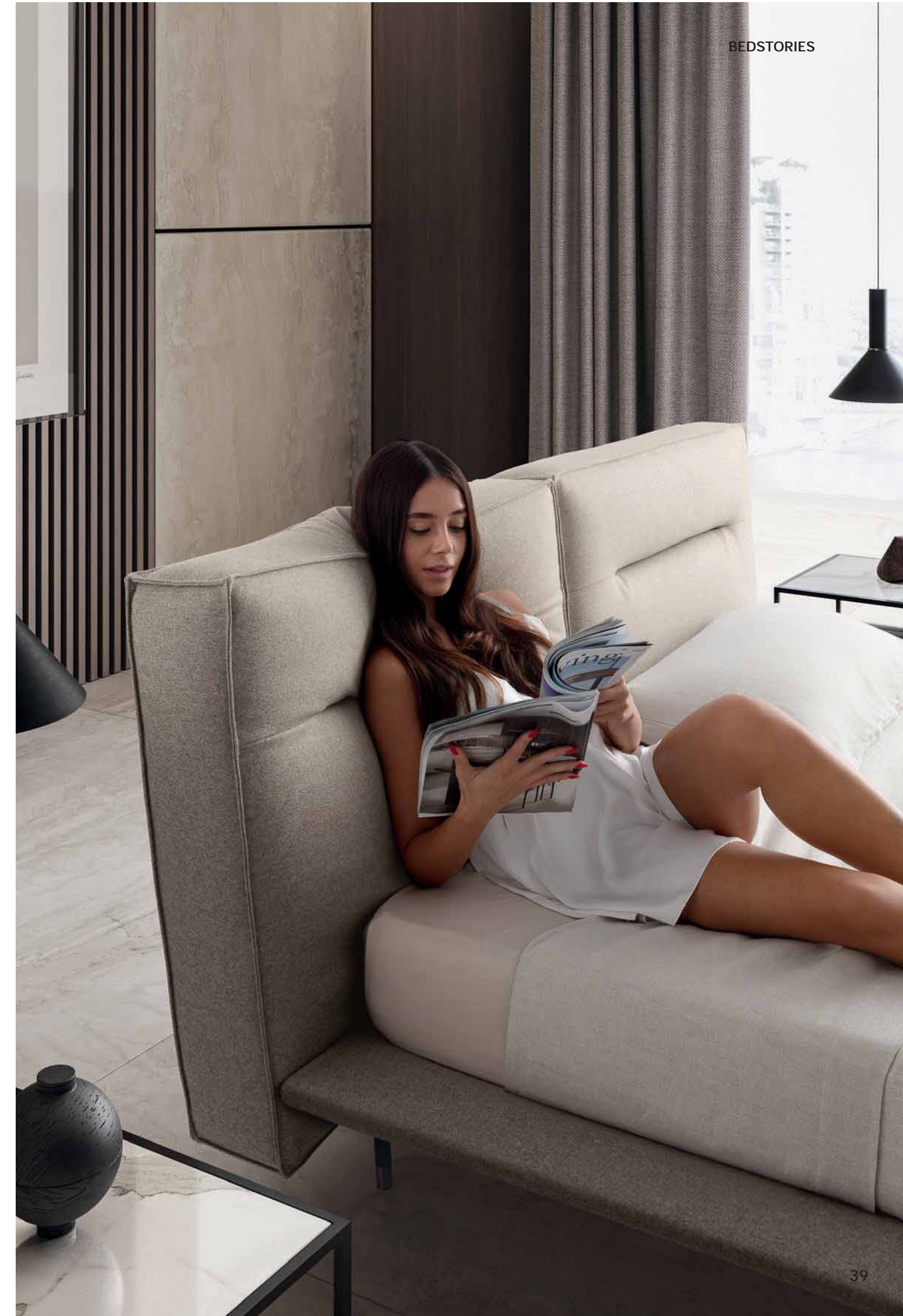









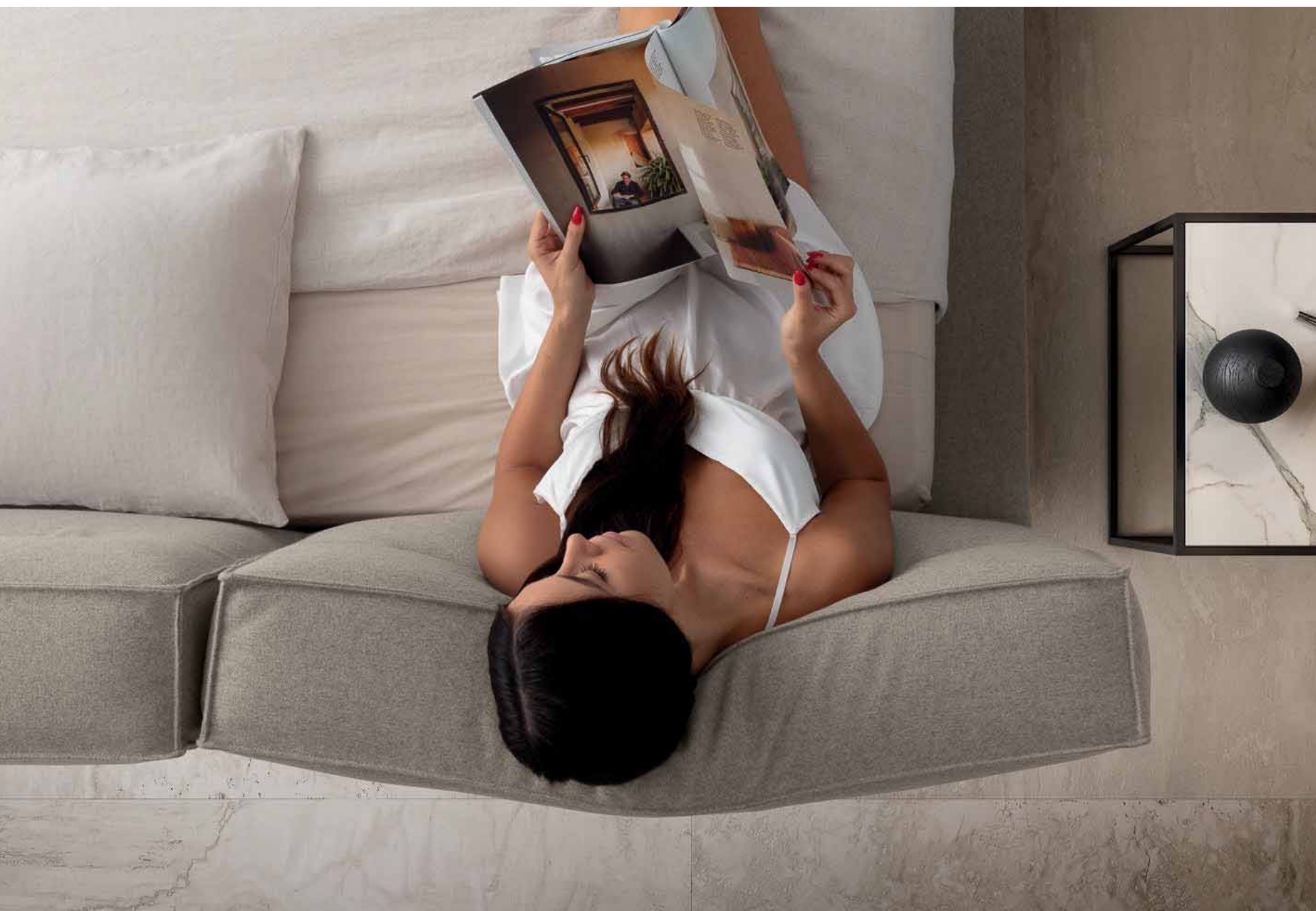

Il cuscino della testiera è una sorpresa di comfort: grazie a un molleggio interno, adatta la sua forma per sorreggere e avvolgere la testa e la schiena.

The headboard cushion is surprisingly comfortable: the springing inside fits its shape to sustain and envelop head and back.

Le coussin de la tête de lit est une surprise de confort: grâce aux ressorts à l'intérieur sa forme s'adapte pour soutenir et enrouler la tête et le dos.

Das Kissen des Kopfteils bietet überraschend viel Komfort: dank seiner internen Federung, passt es sich in der Form an, um Kopf und Rücken gut aufzunehmen und abzustützen.

Il piedino a stiletto è proposto con il puntale in evidenza rispetto al resto della struttura. Moonlight è disponibile anche in versione letto singolo.

The toe cap of the stiletto foot is highlighted compared to the remaining structure. Moonlight is also available in the single bed option.

Le petit pied aiguille est proposé avec la pointe mise en valeur par rapport au reste de la structure. Moonlight est disponible également en version lit simple.

Die Spitze des Stiletto-Fußes wird betont und fällt im Vergleich zum Rest der Struktur sofort ins Auge. Moonlight ist auch in der Version als Einzelbett erhältlich.



**CLOUD SYSTEM: LEGGERO COME UNA NUVOLOLA / CLOUD SYSTEM: AS LIGHT AS A CLOUD**  
 / SYSTÈME CLOUD: LÉGER COMME UN NUAGE / CLOUD SYSTEM: SO LEICHT WIE EINE WOLKE



Tutti abbiamo sognato almeno una volta di dormire su una nuvola. Grazie al sistema di barre Cloud System, il letto appare sospeso e offre la sensazione di fluttuare leggeri nell'aria.

Nous avons tous rêvé au moins une fois de dormir sur un nuage. Grâce au système de barres du Système Cloud, le lit semble suspendu et offre la sensation de fluctuer légers dans l'air.

We all dreamed just once to sleep on a cloud. By the bar system Cloud System, the bed appears to be suspended and gives you the feeling you are floating in mid air.

Wir alle haben schon einmal davon geträumt, auf einer Wolke zu schlafen. Dank des mit Stangen arbeitenden Cloud Systems scheint das Bett zu schweben und suggeriert das Gefühl, leicht in der Luft zu gleiten.

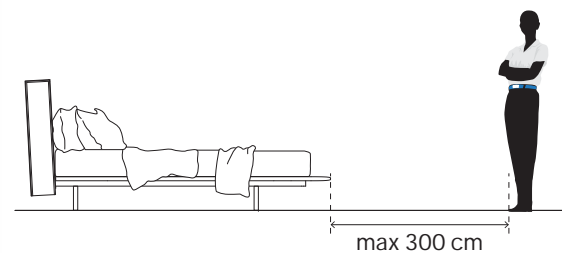

**RING CON TECNOLOGIA ANTISHOCK / BEDFRAME WITH ANTISHOCK TECHNOLOGY**  
 / CADRE DE LIT AVEC TECHNOLOGIE ANTI SHOCK / BETTGESTELL MIT ANTIAUFPRALL-TECHNOLOGIE

L'imbottitura del ring è realizzata con una gomma a elevata densità che consente di attutire eventuali occasioni di impatto con il telaio. Una protezione para-colpi studiata per massimizzare nello stesso tempo sicurezza e piacere estetico.

Le rembourrage du cadre est réalisé avec une gomme à haute densité qui permet d'amortir d'éventuels impacts avec la structure. Une protection tour de lit étudiée afin d'augmenter également sécurité et plaisir esthétique.

The bedframe padding is made of a high density rubber allowing to cushion any impacts with the frame. A shock absorber protection developed to maximize at the same time safety and aesthetic pleasure.

Die Polsterung des Bettgestells besteht aus hochdichtem Gummi, das jeden Aufprall auf den Rahmen abfedert. Ein Stoßschutz, der angenehm anzusehen ist und auch für mehr Sicherheit sorgt.

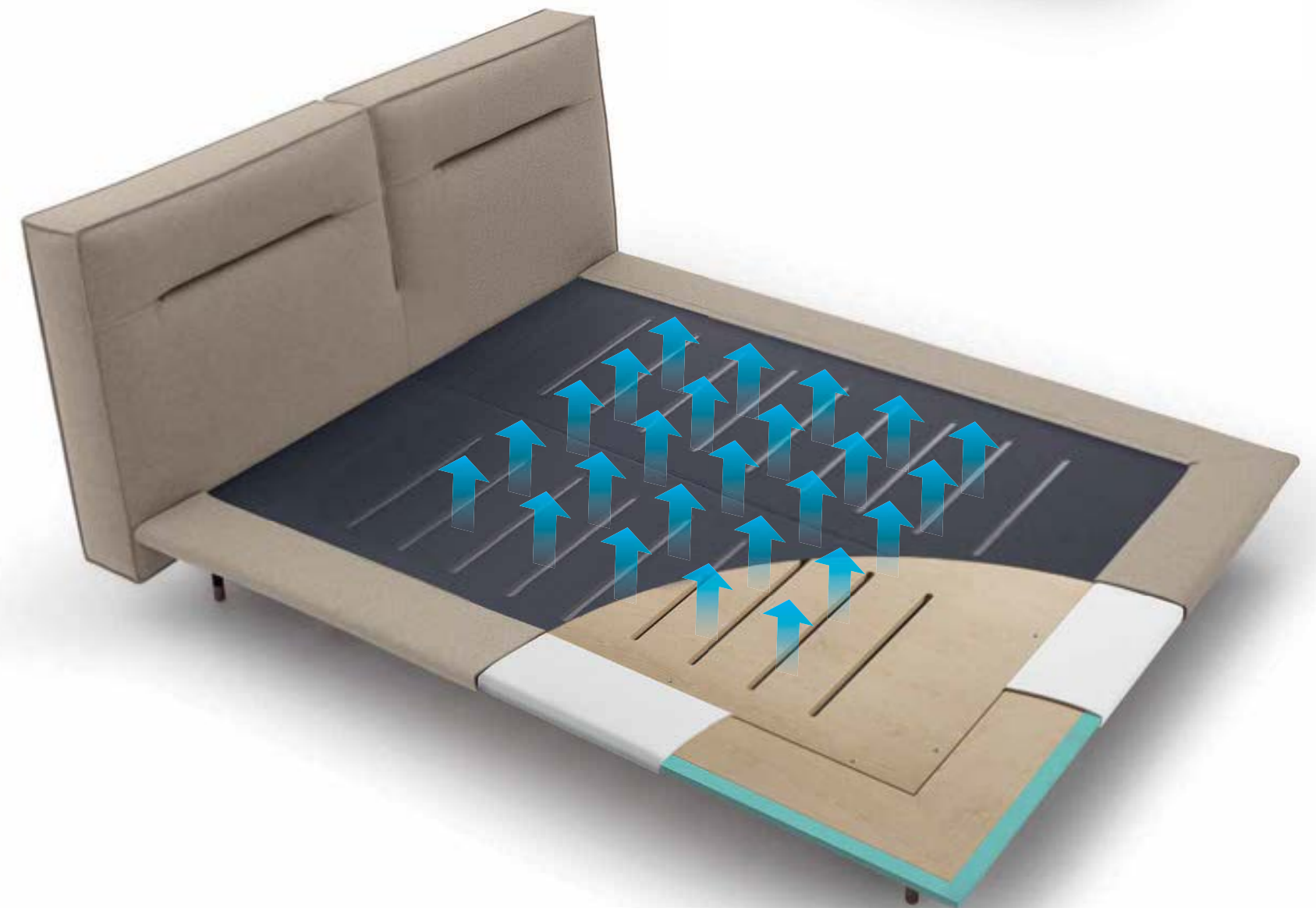
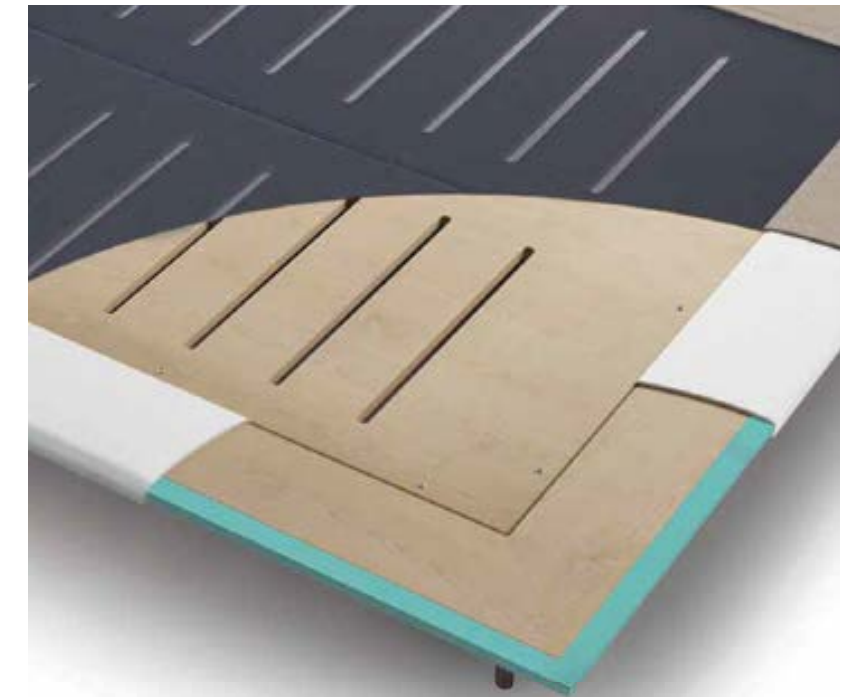

# Moonlight

COMPLETAMENTE SFODERABILE / COMPLETELY REMOVABLE FABRIC / COMPLÈTEMENT DÉHOUSSABLE / VOLLSTÄNDIG ABZIEHBAR

## TESTIERA

**TELAIO** in multistrato di legno di pioppo in classe E1 da 18 mm a bassa emissione di formaldeide e fibra di legno naturale.

**ESPANSI** di poliuretano indeformabile a portanza differenziata. Olmosoft 22 / D40 rivestito con falda termolegata da 300g/mq.

**PRIMO RIVESTIMENTO** in resinato 200 gr. poliestere accoppiato a vellutino in maglina.

## PANNELLI

**TELAIO** in multistrato di legno di pioppo in classe E1 da 20 mm a bassa emissione di formaldeide e fibra di legno naturale.

**PRIMO RIVESTIMENTO** in resinato 200 gr. poliestere accoppiato a vellutino in maglina e tessuto 3D traspirante.

## RETE

Tubolare in metallo a sezione rettangolare verniciata con polveri epossidiche.

## HEADBOARD

Poplar plywood **FRAME** 18 mm in E1 class at low formaldehyde emissions and natural wood fiber.

**POLYURETHANE FOAM** crushproof of different capacity. Olmosoft 22 / D40 covered with staple thermo bonded 300g/mq.

**FIRST COVER** in resin fabric 200 gr. polyester bonding knitted light velvet and breathable 3D fabric.

**PANELS** Poplar plywood **FRAME** 20 mm in E1 class at low formaldehyde emissions and natural wood fiber.

**FIRST COVER** in resin fabric 200 gr. polyester bonding knitted light velvet and breathable 3D fabric.

## BED BASE

Rectangular cross-section metal tubing, epoxy painted.

## TÊTE DE LIT

**STRUCTURE** en multicouches de peuplier classe E1 de 18 mm à basse émission de formaldéhyde et fibre de bois naturel.

**EXPANSÉS** de polyuréthane indéformable à portance différenciée. Olmosoft 22 / D40 revêtu avec bord thermo-lié de 300 g. /m<sup>2</sup>.

**PREMIER REVÊTEMENT** en résiné 200 gr. polyester accouplé à du velours en maille.

**PANNEAUX** **STRUCTURE** en multicouches de peuplier classe E1 de 20 mm. à basse émission de formaldéhyde et fibre de bois naturel.

**PREMIER REVÊTEMENT** en résiné 200 gr. polyester accouplé à du velours en maille et tissu 3D transpirant.

## SOMMIER

Tubulaire en métal à section rectangulaire verni aux poudres époxydes.

## KOPFTEIL

**RAHMEN** aus Pappelmehrschichtholz mit 18 mm Schichtdicke der Klasse E1, geringer Formaldehydabgabe und natürlichen Holzfasern.

Formbeständiger Polyurethan**SCHAUM** mit differenzierter Tragfähigkeit. Olmosoft 22 / D40 verkleidet mit heiß verbundener Schicht zu 300g/qm.

**ERSTE VERKLEIDUNG** aus 200 g Polyesterharz mit aufkaschiertem Samt.

**PANEELE** **RAHMEN** aus Pappelmehrschichtholz mit 20 mm Schichtdicke der Klasse E1, geringer Formaldehydabgabe und natürlichen Holzfasern.

**ERSTE VERKLEIDUNG** aus 200 g Polyesterharz mit aufkaschiertem Samt und atmungsaktivem 3D-Gewebe.

## BETTENROST

Vierkantrohr mit rechteckigem Querschnitt, mit Epoxidpulver lackiert.



## RING TESSUTO / FABRIC RING / CADRE TISSU / BETTGESTELL STOFF

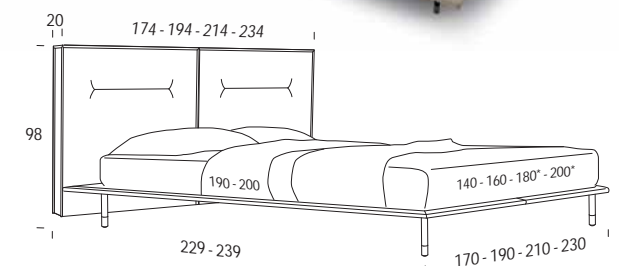

## RING LEGNO / WOOD RING / CADRE BOIS / BETTGESTELL HOLZ

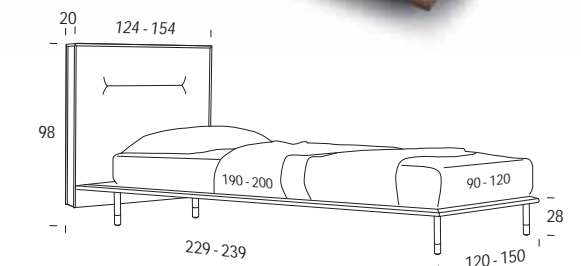

Ring in legno disponibile con L. 160 - 180 - 200  
/ Wood frame available with L.160 - 180 - 200  
/ Cadre en bois disponible en L. 160 - 180 - 200  
/ Bettgestell aus Holz mit B. 160 - 180 - 200 erhältlich

## TESSUTO TRASPIRANTE / BREATHABLE FABRIC / TISSU TRANSPIRANT / ATMUNGSAKTIVER STOFF



Il tessuto che copre i pannelli è un tessuto 3D antipolvere che lascia però passare l'aria, tenendo il materasso asciutto e pulito.  
The fabric covering the panels is a 3D dustproof textile allowing air through and keeping the mattress dry and clean.  
Le tissu qui couvre les panneaux est un tissu 3D anti-poussière qui laisse passer par contre l'air, en conservant le matelas sec et propre.  
Der Stoff zur Verkleidung der Paneele ist ein vor Staub schützendes 3D-Gewebe, das luftdurchlässig ist und die Matratze trocken und sauber hält.

\* Rete L. 180 e L. 200 cm solo profondità 200 cm / Support W. 180 and W. 200 cm only D 200 cm / Sommier L. 180 et L. 200 cm uniquement en profondeur 200 cm / Attenrost B. 180 und B. 200 cm nur mit Tiefe 200 cm

## PIEDE CHOKO H 21 / Choko foot H 21 / Pied Choko H 21 / Fuss Choko H 21

Pag 544



Cioccolato / Chocolate  
/ Chocolat / Schokolade

## CLOUD SYSTEM

Pag 544



Nero opaco / Mat black  
/ Noir mat / Mattschwarz

Disponibile per materasso  
Available for mattress  
Disponible pour matelas  
Verfügbar für Matratze  
L.160-180-200

# Elle



Struttura minimal e sottile, Elle racchiude nel nome la sua forma: una L ribaltata, caratterizzata dal ring basso di ispirazione giapponese e percorsa da una fascia personalizzabile.

With its minimalist and thin structure, Elle includes its form in the name: a reversed L sporting a low ring japanese-inspired and framed by a customizable band.

Structure minimaliste et fine. Elle renferme sa forme dans son nom : une lettre L renversée, caractérisée par un cadre de lit bas d'inspiration japonaise et parcourue par une bande personnalisable.

Die minimalistische und schlanke Struktur von Elle trägt ihren Namen zu Recht: ein gekipptes L, das sich durch ein japanisch inspiriertes Bettgestell auszeichnet und von einem anpassbaren Streifen durchzogen wird.





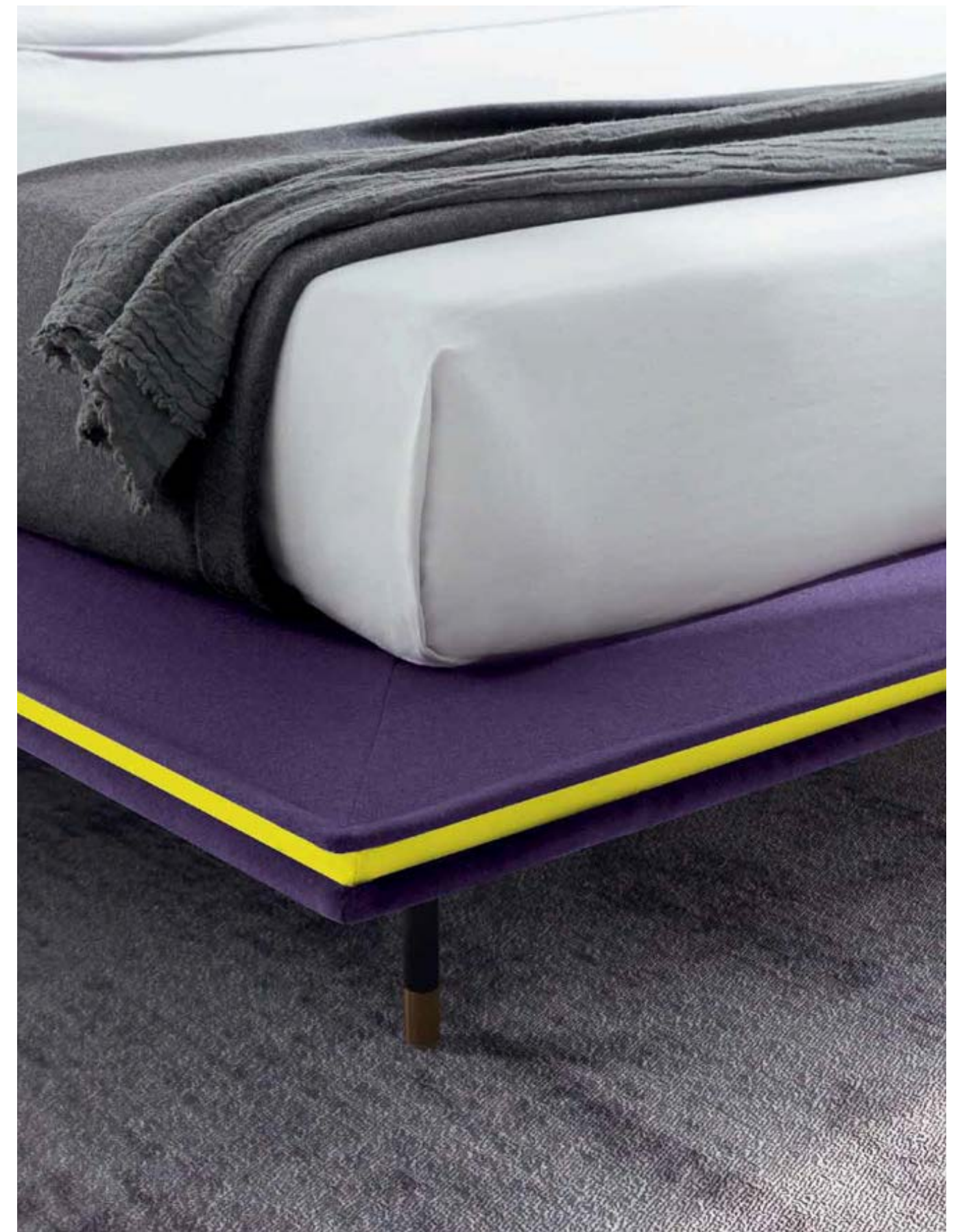

La fascia interna di tessuto, sui lati di ring e testiera, è il dettaglio che definisce lo stile di Elle. Può essere interpretata in tinta o osando a contrasto.

The fabric inner band, on the sides of ring and headboard, is the detail defining Elle style and may be colour-matched or contrasting.

La bande interne de tissu, sur les côtés du cadre et la tête de lit, est le détail qui définit le style d'Elle. Elle peut être interprétée en teinte ou si vous osez en contraste.

Der an den Seiten des Gestells und am Kopfteil innen angebrachte Stoffstreifen ist das Detail, das den Stil von Elle ausmacht. Der Streifen kann Ton-in-Ton oder in einer Kontrastfarbe ausgeführt werden.









Il pianale multistrato, completamente a vista, garantisce un confortevole riposo. Il letto è 100% sfoderabile ed è disponibile anche in versione singola.

The plywood bed plan, totally visible, allows a comfortable rest. The cover of the bed is 100% removable and also available in single bed version.

La plate-forme multicouches, entièrement à vue, garantit un repos confortable. Le lit est 100% déhoussable et est aussi disponible en version simple.

Die mehrschichtige Liegefläche ist frei sichtbar und sorgt für eine angenehme Nachtruhe. Das Bett ist zu 100% abziehbar und auch als Einzelbett erhältlich.

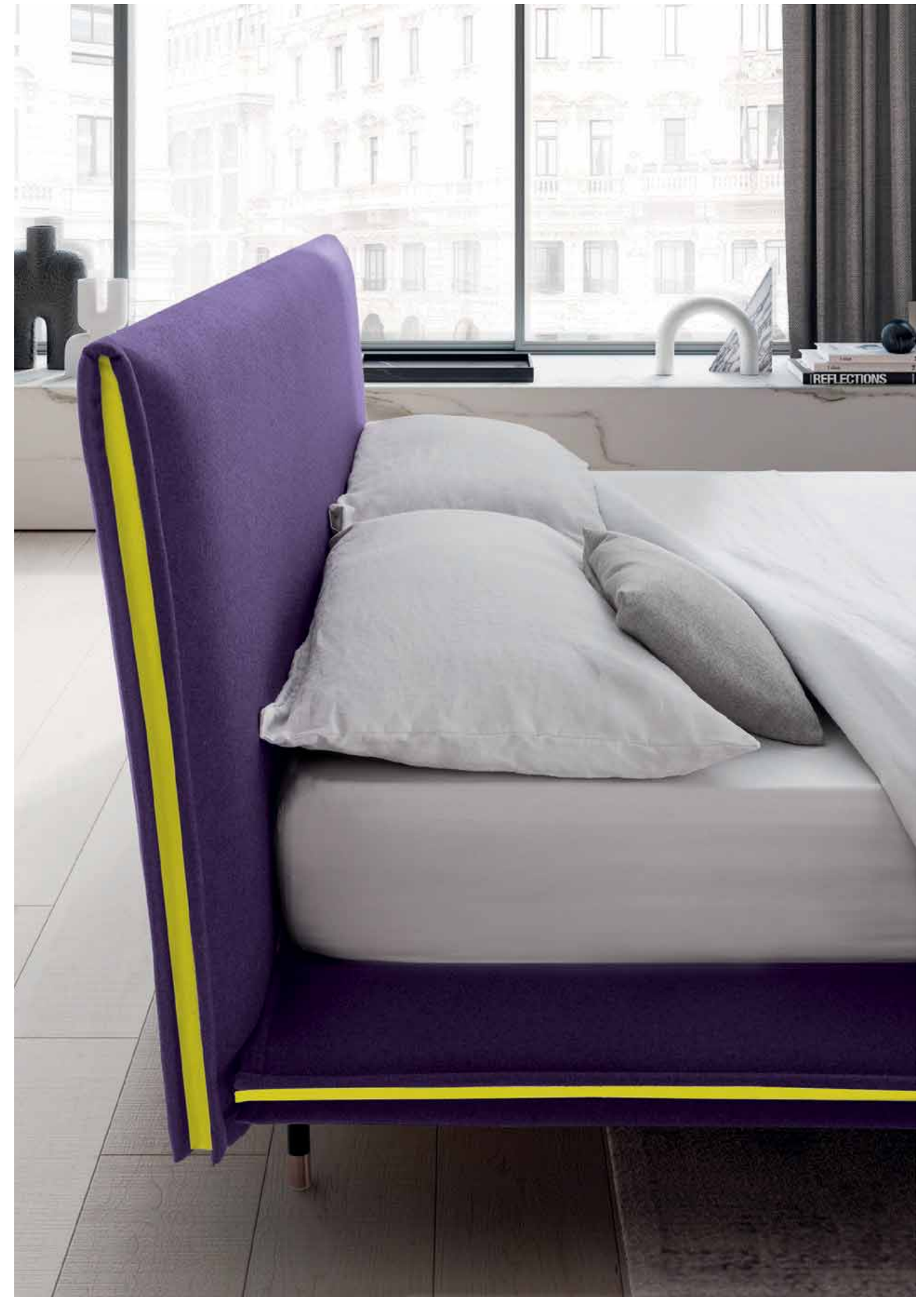

**CLOUD SYSTEM: LEGGERO COME UNA NUVOLOLA / CLOUD SYSTEM: AS LIGHT AS A CLOUD**  
 / SYSTÈME CLOUD : LÉGER COMME UN NUAGE / CLOUD SYSTEM: SO LEICHT WIE EINE WOLKE



Tutti abbiamo sognato almeno una volta di dormire su una nuvola. Grazie al sistema di barre Cloud System, il letto appare sospeso e offre la sensazione di fluttuare leggeri nell'aria.

We all dreamed just once to sleep on a cloud. By the bar system Cloud System, the bed appears to be suspended and gives you the feeling you are floating in mid air.

Nous avons tous rêvé au moins une fois de dormir sur un nuage. Grâce au système de barres du Système Cloud, le lit semble suspendu et offre la sensation de fluctuer légers dans l'air.

Wir alle haben schon einmal davon geträumt, auf einer Wolke zu schlafen. Dank des mit Stangen arbeitenden Cloud Systems scheint das Bett zu schweben und suggeriert das Gefühl, leicht in der Luft zu gleiten.

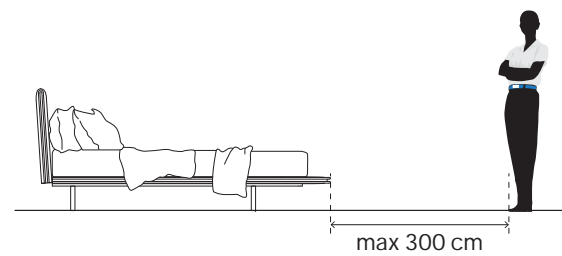

**RING CON TECNOLOGIA ANTISHOCK / BEDFRAME WITH ANTISHOCK TECHNOLOGY**  
 / CADRE DE LIT AVEC TECHNOLOGIE ANTI SHOCK / BETTGESTELL MIT ANTIAUFPRALL-TECHNOLOGIE

L'imbottitura del ring è realizzata con una gomma a elevata densità che consente di attutire eventuali occasioni di impatto con il telaio. Una protezione para-colpi studiata per massimizzare nello stesso tempo sicurezza e piacere estetico.

The ring padding is made of a high density rubber allowing to cushion any impacts with the frame. A shock absorber protection developed to maximize at the same time safety and aesthetic pleasure.

Le rembourrage du cadre est réalisé avec une gomme à haute densité qui permet d'amortir d'éventuels impacts avec la structure. Une protection tour de lit étudiée afin d'augmenter également sécurité et plaisir esthétique.

Die Polsterung des Bettgestells besteht aus hochdichtem Gummi, das jeden Aufprall auf den Rahmen abfedert. Ein Stoßschutz, der angenehm anzusehen ist und auch für mehr Sicherheit sorgt.

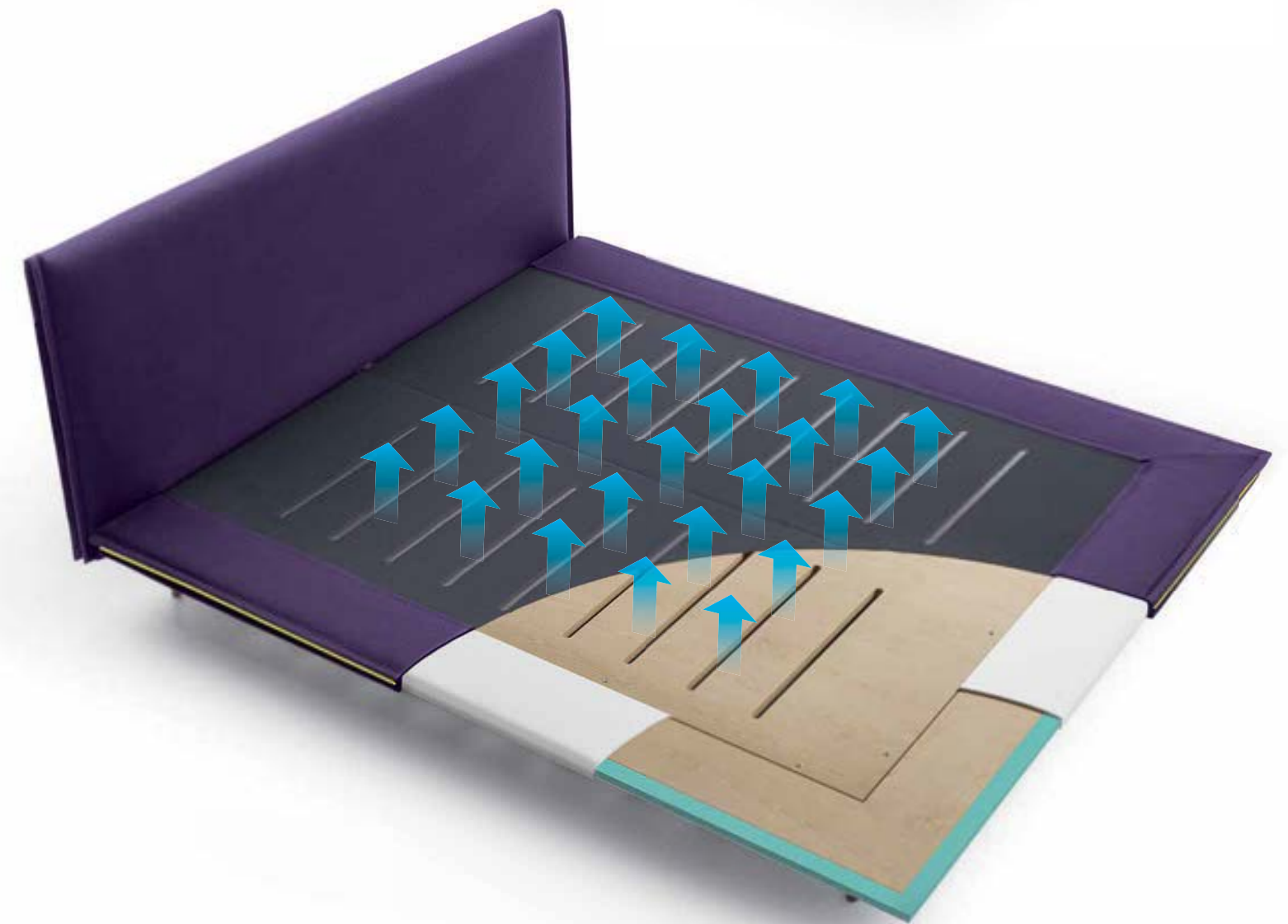

# Elle

COMPLETAMENTE SFODERABILE / COMPLETELY REMOVABLE FABRIC / COMPLÈTEMENT DÉHOUSSABLE / VOLLSTÄNDIG ABZIEHBAR

## TESTIERA

**TELAIO** in multistrato di legno di pioppo in classe E1 da 18 mm a bassa emissione di formaldeide e fibra di legno naturale.

**ESPANSI** di poliuretano indeformabile a portanza differenziata. Olmosoft 22 / D40 rivestito con falda termolegata da 300g/mq.

**PRIMO RIVESTIMENTO** in resinato 200 gr. poliestere accoppiato a vellutino in maglina.

## PANNELLI

**TELAIO** in multistrato di legno di pioppo in classe E1 da 20 mm a bassa emissione di formaldeide e fibra di legno naturale.

**PRIMO RIVESTIMENTO** in resinato 200 gr. poliestere accoppiato a vellutino in maglina e tessuto 3D traspirante.

## RETE

Tubolare in metallo a sezione rettangolare verniciata con polveri epossidiche.

## HEADBOARD

Poplar plywood **FRAME** 18 mm in E1 class at low formaldehyde emissions and natural wood fiber.

**POLYURETHANE FOAM** crushproof of different capacity. Olmosoft 22 / D40 covered with staple thermo bonded 300g/mq. **FIRST COVER** in resin fabric 200 gr. polyester bonding knitted light velvet and breathable 3D fabric.

## PANELS

Poplar plywood **FRAME** 20 mm in E1 class at low formaldehyde emissions and natural wood fiber.

**FIRST COVER** in resin fabric 200 gr. polyester bonding knitted light velvet and breathable 3D fabric.

## FRAME

Rectangular cross-section metal tubing, epoxy painted.

## TÊTE DE LIT

**STRUCTURE** en multicouches de peuplier classe E1 de 18 mm à basse émission de formaldéhyde et fibre de bois naturel.

**EXPANSÉS** de polyuréthane indéformable à portance différenciée. Olmosoft 22 / D40 revêtu avec bord thermo-lié de 300 g. /m².

**PREMIER REVÊTEMENT** en résiné 200 gr. polyester accouplé à du velours en maille.

## PANNEAUX

**STRUCTURE** en multicouches de peuplier classe E1 de 20 mm. à basse émission de formaldéhyde et fibre de bois naturel.

**PREMIER REVÊTEMENT** en résiné 200 gr. polyester accouplé à du velours en maille et tissu 3D transpirant.

## SOMMIER

Tubulaire en métal à section rectangulaire verni aux poudres époxydes.

## KOPFTEIL

**RAHMEN** aus Pappelmehrschichtholz mit 18 mm Schichtdicke der Klasse E1, geringer Formaldehydabgabe und natürlichen Holzfasern.

Formbeständiger Polyurethan**SCHAUM** mit differenzierter Tragfähigkeit. Olmosoft 22 / D40 verkleidet mit heiß verbundener Schicht zu 300g/qm.

**ERSTE VERKLEIDUNG** aus 200 g Polyesterharz mit aufkaschiertem Samt.

## PANEELE

**RAHMEN** aus Pappelmehrschichtholz mit 20 mm Schichtdicke der Klasse E1, geringer Formaldehydabgabe und natürlichen Holzfasern.

**ERSTE VERKLEIDUNG** aus 200 g Polyesterharz mit aufkaschiertem Samt und atmungsaktivem 3D-Gewebe.

## BETTENROST

Vierkantrohr mit rechteckigem Querschnitt, mit Epoxidpulver lackiert.

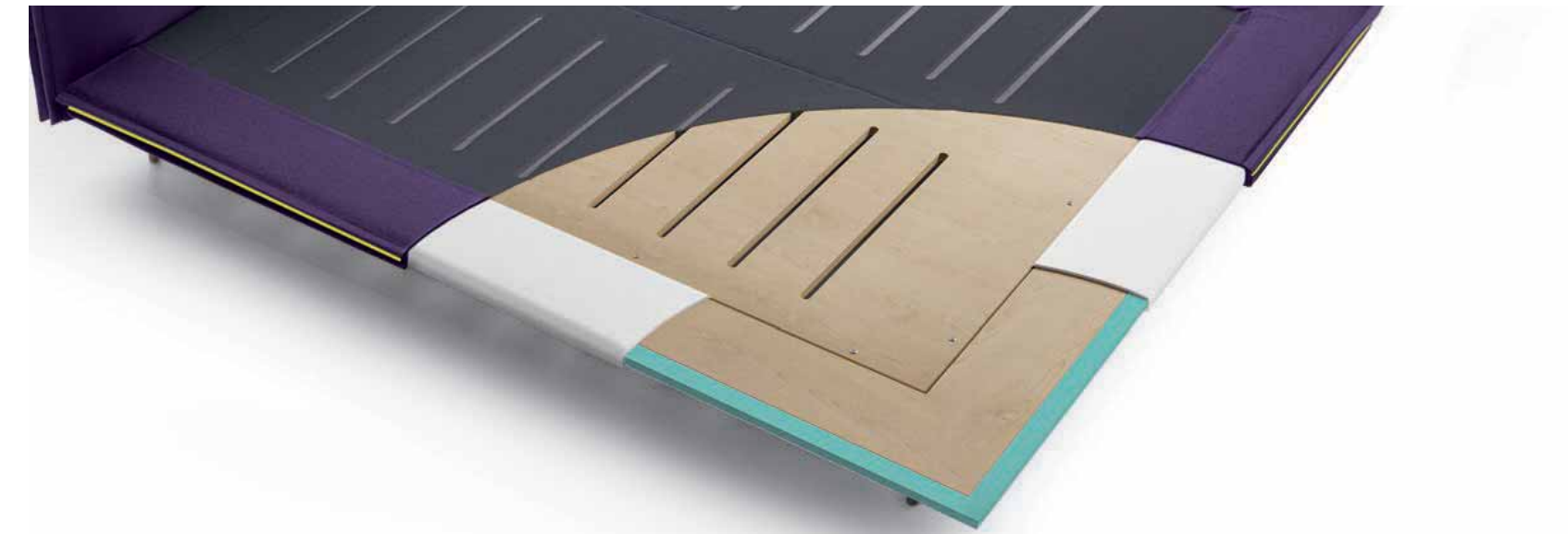

### RING TESSUTO / FABRIC RING / CADRE TISSU / BETTGESTELL STOFF

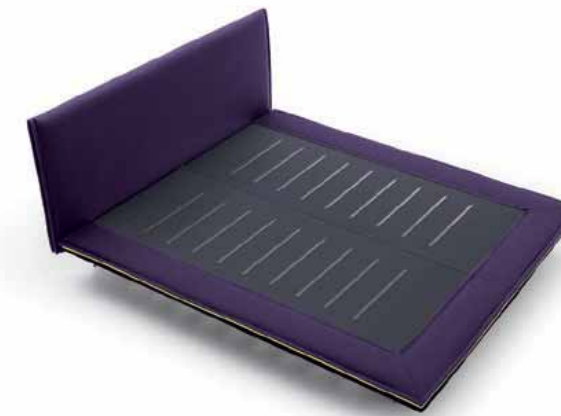

### RING LEGNO / WOOD RING / CADRE BOIS / BETTGESTELL HOLZ



Ring in legno disponibile con L. 160 - 180 - 200  
/ Wood frame available with L.160 - 180 - 200  
/ Cadre en bois disponible en L. 160 - 180 - 200  
/ Bettgestell aus Holz mit B. 160 - 180 - 200 erhältlich

### TESSUTO TRASPIRANTE / BREATHABLE FABRIC / TISSU TRANSPIRANT / ATMUNGSAKTIVER STOFF

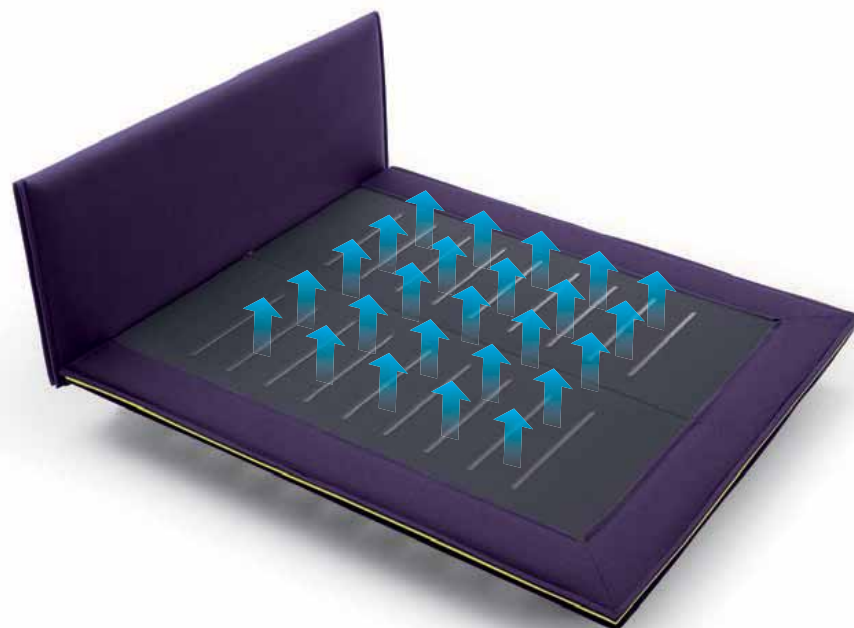

Il tessuto che copre i pannelli è un tessuto 3D antipolvere che lascia però passare l'aria, tenendo il materasso asciutto e pulito.  
The fabric covering the panels is a 3D dustproof textile allowing air through and keeping the mattress dry and clean.  
Le tissu qui couvre les panneaux est un tissu 3D anti-poussière qui laisse passer par contre l'air, en conservant le matelas sec et propre.  
Der Stoff zur Verkleidung der Paneele ist ein vor Staub schützendes 3D-Gewebe, das luftdurchlässig ist und die Matratze trocken und sauber hält.

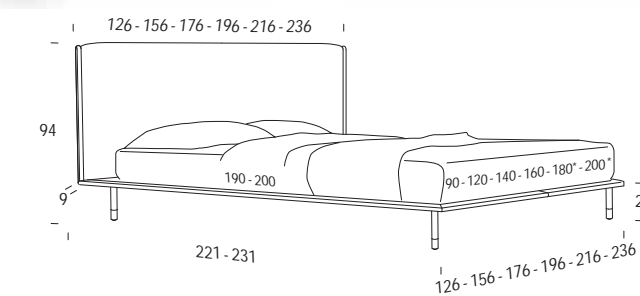

\* Rete L. 180 e L. 200 cm solo profondità 200 cm / Support W. 180 and W. 200 cm only D 200 cm / Sommier L. 180 et L. 200 cm uniquement en profondeur 200 cm / Attenrost B. 180 und B. 200 cm nur mit Tiefe 200 cm

### PIEDE CHOKO H 21 / Choko foot H 21 / Pied Choko H 21 / Fuss Choko H 21

Pag 544



Cioccolato / Chocolate  
/ Chocolat / Schokolade

### CLOUD SYSTEM

Pag 544



Nero opaco / Mat black  
/ Noir mat / Mattschwarz

Disponibile per materasso  
Available for mattress  
Disponible pour matelas  
Verfügbar für Matratze  
L.160-180-200

# Hug Collection

Dormire in un abbraccio, avvolti tra le ali di una testiera che protegge i nostri sonni. La collezione Hug è composta da letti dalla forte presenza e personalità, con giroletti imbottiti ed elementi testiera mobili e removibili per una maggiore funzionalità e personalizzazione del comfort. Con Hug Collection eleganza e intimità sono di casa.

Sleeping in an embrace, enveloped between the wings of a headboard protecting our sleeps. The Hug collection consists of beds having a strong character and presence, with padded bed frames and headboard elements mobile and removable for a greater functionality and customization of the comfort. With Hug Collection style and intimacy are at home.

Dormir en s'accolant, enroulés entre les ailes d'une tête de lit qui protège notre sommeil. La collection Hug est composée de lits à la forte présence et personnalité, aux têtes de lit rembourrées et aux éléments de tête de lits mobiles et amovibles qui permettent une majeure fonctionnalité et personnalisation du confort. Avec Hug Collection élégance et intimité font partie de la maison.

Hier schläft man wie in einer Umarmung, zwischen den Flügeln eines Kopfteils, das unsere Träume beschützt. Die Kollektion Hug besteht aus Betten mit starker Präsenz und Persönlichkeit, gepolsterten Bettrahmen und beweglichen und abnehmbaren Kopfteilelementen für mehr Funktionalität und individuellen Komfort. Mit der Hug Collection kommen Eleganz und Intimität zu uns ins Haus.

# Gaber



Un autentico protagonista dell'ambiente notte, con una testiera dal design avvolgente, ideale anche a centro stanza.

An authentic bedroom feature piece, with an enveloping headboard design; also ideal in the centre of the room.

Un authentique protagoniste de l'espace nuit, avec une tête de lit au design enveloppant, parfait même au centre de la pièce.

Ein echter Protagonist im Schlafzimmer, der mit seinem besonderen Kopfteil auch ideal für die Aufstellung in der Raummitte ist.







Il rivestimento imbottito del giroletto e della testiera, è solcato da cuciture che creano un piacevole ritmo visivo.

The padded upholstery around the bed frame and headboard features furrowed stitching that creates an appealing visual effect.

Le revêtement rembourré du cadre et de la tête de lit est marqué par des coutures qui créent un agréable rythme visuel.

Der gepolsterte Bezug von Bettrahmen und Kopfteil wird von Nähten durchzogen, die einen angenehmen visuellen Rhythmus erzeugen.







# Gaber

COMPLETAMENTE SFODERABILE / COMPLETELY REMOVABLE FABRIC / COMPLÈTEMENT DÉHOUSSABLE / VOLLSTÄNDIG ABZIEHBAR

**MASSELLI** in legno di abete e/o scatolati in multistrato di legno di pioppo.

**PANNELLI** da 18/25 mm in particelle di legno in classe E1 a bassa emissione di formaldeide e fibra di legno naturale.

**ESPANSI** di poliuretano indeformabile a portanza differenziata, densità da 18 kg/mc a 40 kg/mc.

**PRIMO RIVESTIMENTO** in espanso di poliestere accoppiato a caldo a vellutino aggrappante in poliestere e/o ovatta di poliestere al 100% da 200gr.

**PANNELLI FONDO** contenitore da 12-14 mm in particelle di legno di pioppo in classe E1.

**FORGINGS** fir wood, and/or boxed in poplar plywood.

**PANELS** 18/25 mm in poplar wood particles class E1 low formaldehyde emission and natural wood fiber.

**POLYURETHANE FOAM**, crushproof, of different capacity, density from 18 kg/mc to 40 kg/mc.

**FIRST COATING** hot bonded polyester foam, velvet adhesion in polyester and/or 100% polyester wool, 200gr.

**CONTAINER BOTTOM** panels 12-14 mm in poplar wood particles class E1.

**TIGE** en pin et/ou boitiers en multicouche en bois de peuplier.

**PANNEAUX** de 18/25 mm en particules de bois de peuplier classe E1 à faible émission de formaldéhyde et fibre de bois naturelle.

**POLYURÉTHANE EXPANSÉ** indéformable à portée différenciée, densité de 18kg/m<sup>3</sup> à 40kg/m<sup>3</sup>.

**PREMIER REVÊTEMENT** en polyester expansé accouplé à chaud à un velours accrochant en polyester et/ou ouate de polyester à 100% de 200g.

**PANNEAUX DE FOND COFFRE RANGEMENT** de 12-14mm en particules de bois de peuplier classe E1.

**MASSIVES** Tannenholz und/oder Blöcke aus Pappelmeerschichholz.

**SPANPLATTEN** aus Pappelholz mit 18/25 mm Schichtdicke der Klasse E1, geringer Formaldehydabgabe und natürlichen Holzfasern.

**POLYURETHANSCHAUM**, nicht verformbar und mit differenzierter Tragfähigkeit, Dichten von 18 kg/m<sup>3</sup> bis 40 kg/m<sup>3</sup>.

**ERSTER ÜBERZUG** aus Polyesterschaum, der auf Polyester-Samt und/oder 100% Polyesterwatte (zu 200 g) heiß aufkaschiert wurde.

**BODENPLATTEN** des Bettkastens aus 12-14 mm starken Spanplatten aus Pappelholz der Klasse E1.



Spessore testiera 9 cm  
Headboard thickness 9 cm  
Épaisseur tête de lit 9 cm  
Stärke des Kopfteils 9 cm

## Optional

Rete / Support / Sommier / Lattenrost Pag 548

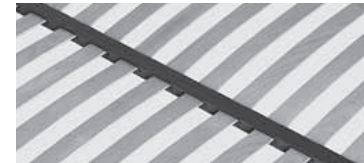

Armony (Standard)

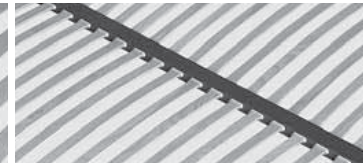

Thai  
46 doghe  
46 slats  
46 attes  
46 Leisten

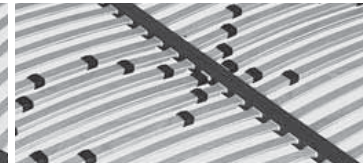

Energy  
Non applicabile a rete da 120 cm  
Not applicable to 120 cm support  
Non applicable au sommier de 120 cm  
Gilt nicht für Lattenrost zu 120 cm

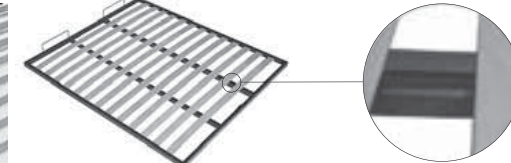

Doppio Flip  
Solo 140/160x190/200 - 180x200  
Only 140/160x190/200 - 180x200  
Uniquement 140/160x190/200 - 180x200  
Nur 140/160x190/200 - 180x200

Pag 552



Sacco contenitore multiuso  
Multipurpose storage bag  
Sac coffre de rangement multi usage  
Mehrzweck-Aufbewahrungstasche

Pag 553



Tessuto coprirete traspirante antipolvere  
Support cover fabric breathable and dustproof  
Tissu couvre-sommier transpirant anti-poussière  
Atmungsaktives, vor Staub schützendes Gewebe

Pag 557



Regolatore altezza rete solo per reti in appoggio  
Support height adjuster only for resting frames  
Réglage hauteur sommier uniquement pour sommiers à poser  
Lattenrost-Höhenverstellung nur für aufliegende Lattenroste

Pag 556



Clean Up System



Elemento testiera mobile e removibile  
Headboard element mobile and removable  
Élément tête de lit mobile et amovible  
Mobiles und abnehmbares Kopfteilelement

## RING BERING

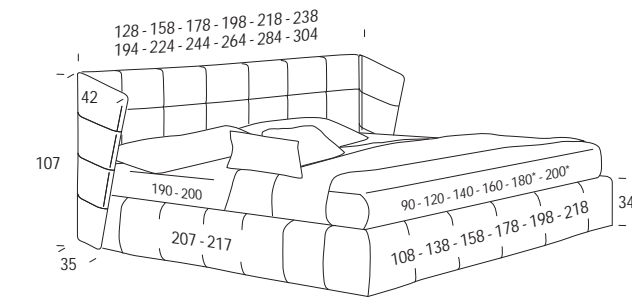

\* Rete L. 180 e L. 200 cm solo profondità 200 cm / Support W. 180 and W. 200 cm only D 200 cm  
/ Sommier L. 180 et L. 200 cm uniquement en profondeur 200 cm / Attenrost B. 180 und B. 200 cm nur mit Tiefe 200 cm

Standard BASIC H 3 Pag 545



Wengé / Wengé / Wengé / Wengé



Nero / Black / Noir / Schwarz



Argento / Silver / Argent / Silber



Bianco / White / Blanc / Weiß

Optional LUX H 3 Pag 545



Wengé / Wengé / Wengé / Wengé



Nero / Black / Noir / Schwarz



Cromo / Chrome / Chrome / Chrom



Bianco / White / Blanc / Weiß

## RING PEAK

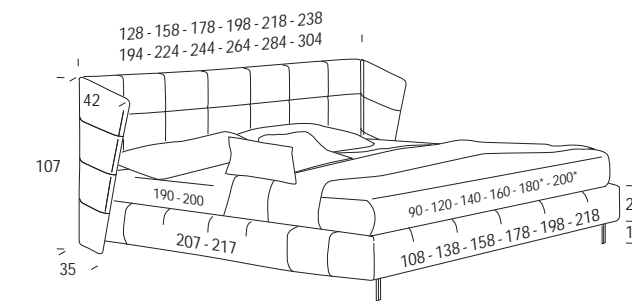

\* Rete L. 180 e L. 200 cm solo profondità 200 cm / Support W. 180 and W. 200 cm only D 200 cm  
/ Sommier L. 180 et L. 200 cm uniquement en profondeur 200 cm / Attenrost B. 180 und B. 200 cm nur mit Tiefe 200 cm

PIEDE TWINNY a doppio stiletto H 13 / Double stiletto Twinny foot H 13

PIEDE BAOBAB in legno H 13 / Baobab wooden feet H 13

/ Pied Twinny double talon H 13 / Fußmodell Twinny mit doppeltem Stilett-Fuß H 13 Pag 544 / Pied Baobab en bois H 13 / Fußmodell Baobab aus Holz H13 Pag 544



Cromo lucido  
Shining chrome  
Chrome brillant  
Chrom Hochglanz



Carbon look lucido  
Shining carbon look  
Carbon look brillant  
Carbon-Look Hochglanz



Nero opaco  
Mat black  
Noir mat  
Mattschwarz



Rovere Londra  
Dak "Londra"  
Chêne "Londra"  
Eiche "Londra"



Rovere tabacco  
Dak "tabacco"  
Chêne "tabacco"  
Eiche "tabacco"



Rovere naturale  
Dak "naturale"  
Chêne "naturale"  
Eiche "naturale"

Optional Pag 550

Meccanica / Mechanism / Mécanique / Mechanisch

Dynamic



Maverick

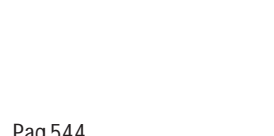

# Foster



La grande testiera imbottita e trapuntata, rende questo letto un vero e proprio protagonista dell'arredo.

The large upholstered, quilted headboard makes this bed the absolute furnishing feature piece.

La grande tête de lit rembourrée et capitonnée fait de ce lit un véritable protagoniste de la décoration.

Das große gepolsterte und gesteppte Kopfteil macht dieses Bett zu einem echten Protagonisten der Einrichtung.







I terminali riposizionabili della testiera, creano una piacevole sensazione di privacy intorno ai cuscini.

The repositionable headboard end panels create an appealing sense of privacy around the pillows.

Les élément terminaux de la tête de lit pouvant être repositionnés créent une agréable sensation d'intimité autour des coussins.

Die verschiebbaren Enden des Kopftheils schaffen ein angenehmes Gefühl von Privatsphäre um die Kissen herum.



# Foster

COMPLETAMENTE SFODERABILE / COMPLETELY REMOVABLE FABRIC / COMPLÈTEMENT DÉHOUSSABLE / VOLLSTÄNDIG ABZIEHBAR

**MASSELLI** in legno di abete e/o scatolati in multistrato di legno di pioppo.  
**PANNELLI** da 18/25 mm in particelle di legno in classe E1 a bassa emissione di formaldeide e fibra di legno naturale.  
**ESPANSI** di poliuretano indeformabile a portanza differenziata, densità da 18 kg/mc a 40 kg/mc.  
**PRIMO RIVESTIMENTO** in espanso di poliestere accoppiato a caldo a vellutino aggrappante in poliestere e/o ovatta di poliestere al 100% da 200gr.  
**PANNELLI FONDO** contenitore da 12-14 mm in particelle di legno di pioppo in classe E1.

**FORGINGS** fir wood, and/or boxed in poplar plywood.  
**PANELS** 18/25 mm in poplar wood particles class E1 low formaldehyde emission and natural wood fiber.  
**POLYURETHANE FOAM**, foam, crushproof, of different capacity, density from 18 kg/mc to 40 kg/mc.  
**FIRST COATING** hot bonded polyester foam, velvet adhesion in polyester and/or 100% polyester wool, 200gr.  
**CONTAINER BOTTOM** panels 12-14 mm in poplar wood particles class E1.

**TIGE** en pin et/ou boitiers en multicouche en bois de peuplier.  
**PANNEAUX** de 18/25 mm en particules de bois de peuplier classe E1 à faible émission de formaldéhyde et fibre de bois naturelle.  
**POLYURÉTHANE EXPANSÉ** indéformable à portée différenciée, densité de 18kg/m<sup>3</sup> à 40kg/m<sup>3</sup>.  
**PREMIER REVÊTEMENT** en polyester expansé accouplé à chaud à un velours accrochant en polyester et/ou ouate de polyester à 100% de 200g.  
**PANNEAUX DE FOND COFFRE RANGEMENT** de 12-14mm en particules de bois de peuplier classe E1.

**MASSIVES** Tannenholz und/oder Blöcke aus Pappelmeerschholz.  
**SPANPLATTEN** aus Pappelholz mit 18/25 mm Schichtdicke der Klasse E1, geringer Formaldehydabgabe und natürlichen Holzfasern.  
**POLYURETHANSCHAUM**, nicht verformbar und mit differenzierter Tragfähigkeit, Dichten von 18 kg/m<sup>3</sup> bis 40 kg/m<sup>3</sup>.  
**ERSTER ÜBERZUG** aus Polyesterschaum, der auf Polyester-Samt und/oder 100% Polyesterwatte (zu 200 g) heiß aufkaschiert wurde.  
**BODENPLATTEN** des Bettkastens aus 12-14 mm starken Spanplatten aus Pappelholz der Klasse E1.



Spessore testiera 9 cm  
 Headboard thickness 9 cm  
 Épaisseur tête de lit 9 cm  
 Stärke des Kopfteils 9 cm

## Optional

Rete / Support / Sommier / Lattenrost Pag 548

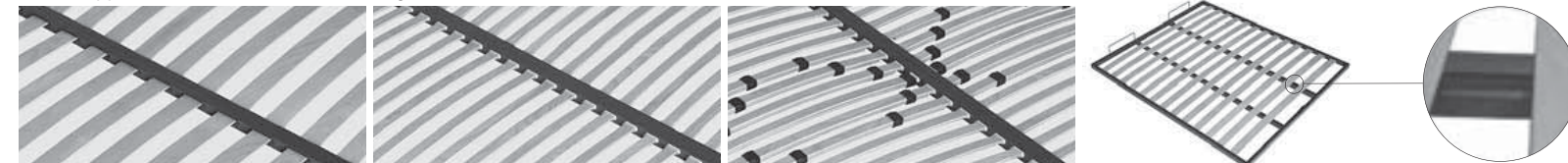

**Armony**  
(Standard)

**Thai**  
46 doghe  
46 slats  
46attes  
46 Leisten

**Energy**  
Non applicabile a rete da 120 cm  
Not applicable to 120 cm support  
Non applicable au sommier de 120 cm  
Gilt nicht für Lattenrost zu 120 cm

**Doppio Flip**  
Solo 140/160x190/200 - 180x200  
Only 140/160x190/200 - 180x200  
Uniquement 140/160x190/200 - 180x200  
Nur 140/160x190/200 - 180x200

Pag 552



**Sacco contenitore multiuso**  
Multipurpose storage bag  
Sac coffre de rangement multi usage  
Mehrzweck-Aufbewahrungstasche

Pag 553



**Tessuto coprirete traspirante antipolvere**  
Support cover fabric breathable and dustproof  
Tissu couvre-sommier transpirant anti-poussière  
Atmungsaktives, vor Staub schützendes Gewebe

Pag 557



**Regolatore altezza rete solo per reti in appoggio**  
Support height adjuster only for resting frames  
Réglage hauteur sommier uniquement pour sommiers à poser  
Lattenrost-Höhenverstellung nur für aufliegende Lattenroste

Pag 556



**Clean Up System**



**Elemento testiera mobile e removibile**  
Headboard element mobile and removable  
Élément tête de lit mobile et amovible  
Mobiles und abnehmbares Kopfteilelement

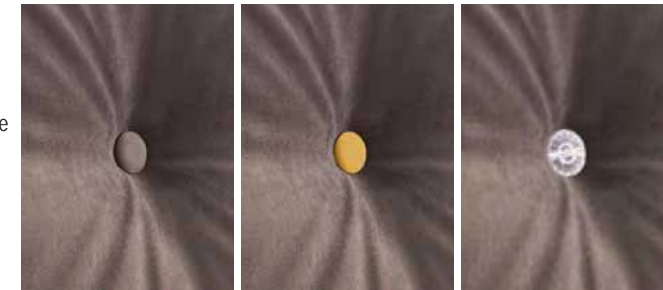

**Bottoni Ø18mm tinta unita come il tessuto, in contrasto o Swarovski bianco**  
Buttons in the same color as the fabric or contrasting or with Swarovski  
Boutons couleur tissu ou en contraste ou Swarovski blanc  
Knöpfe Ø18mm in der gleichen Farbe wie der Stoff, in einer Kontrastfarbe oder als weiße Swarovskis

## RING BERING

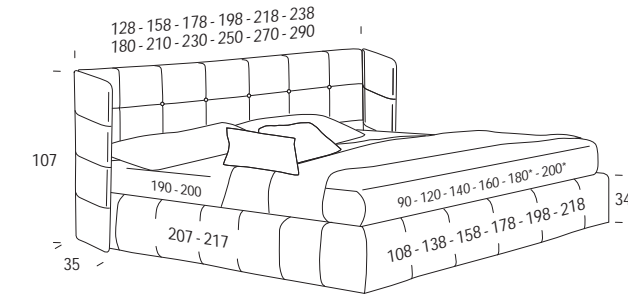

\* Rete L. 180 e L. 200 cm solo profondità 200 cm / Support W. 180 and W. 200 cm only D 200 cm  
 / Sommier L. 180 et L. 200 cm uniquement en profondeur 200 cm / Attenrost B. 180 und B. 200 cm nur mit Tiefe 200 cm

Standard BASIC H 3 Pag 545

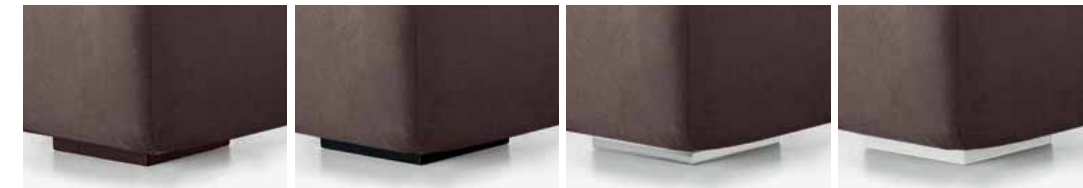

Wengé / Wengé / Wengé / Wengé Nero / Black / Noir / Schwarz Argento / Silver / Argent / Silber Bianco / White / Blanc / Weiß

Optional LUX H 3 Pag 545



Wengé / Wengé / Wengé / Wengé Nero / Black / Noir / Schwarz Cromo / Chrome / Chrome / Chrom Bianco / White / Blanc / Weiß

Optional Pag 550

Meccanica / Mechanism / Mécanique / Mechanisch

Dynamic

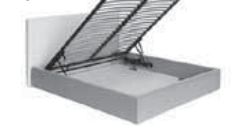

Maverick

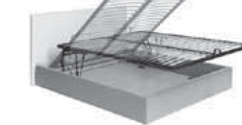

## RING PEAK

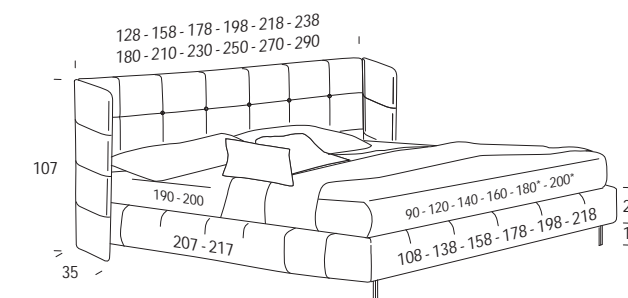

\* Rete L. 180 e L. 200 cm solo profondità 200 cm / Support W. 180 and W. 200 cm only D 200 cm  
 / Sommier L. 180 et L. 200 cm uniquement en profondeur 200 cm / Attenrost B. 180 und B. 200 cm nur mit Tiefe 200 cm

PIEDE TWINNY a doppio stiletto H 13 / Double stiletto Twinny foot H 13

PIEDE BAOBAB in legno H 13 / Baobab wooden feet H 13

/ Pied Twinny double talon H 13 / Fußmodell Twinny mit doppeltem Stilet-Fuß H 13 Pag 544 / Pied Baobab en bois H 13 / Fußmodell Baobab aus Holz H13 Pag 544



**Cromo lucido**  
Shining chrome  
Chrome brillant  
Chrom Hochglanz

**Carbon look lucido**  
Shining carbon look  
Carbon look brillant  
Carbon-Look Hochglanz

**Nero opaco**  
Mat black  
Noir mat  
Mattschwarz

**Rovere Londra**  
Dak "Londra"  
Chêne "Londra"  
Eiche "Londra"

**Rovere tabacco**  
Dak "tabacco"  
Chêne "tabacco"  
Eiche "tabacco"

**Rovere naturale**  
Dak "naturale"  
Chêne "naturale"  
Eiche "naturale"

# Spencer



L'ampia testiera di questo letto crea una sensazione di rassicurante comfort, in un connubio di attualità e tradizione.

The imposing headboard on this bed creates a reassuring sense of comfort, bringing past and present together.

L'ample tête de ce lit crée une sensation de confort rassurant, dans un mélange d'actualité et tradition.

Das große Kopfteil dieses Bettes schafft ein Gefühl von beruhigendem Komfort und verbindet Modernität mit Tradition.

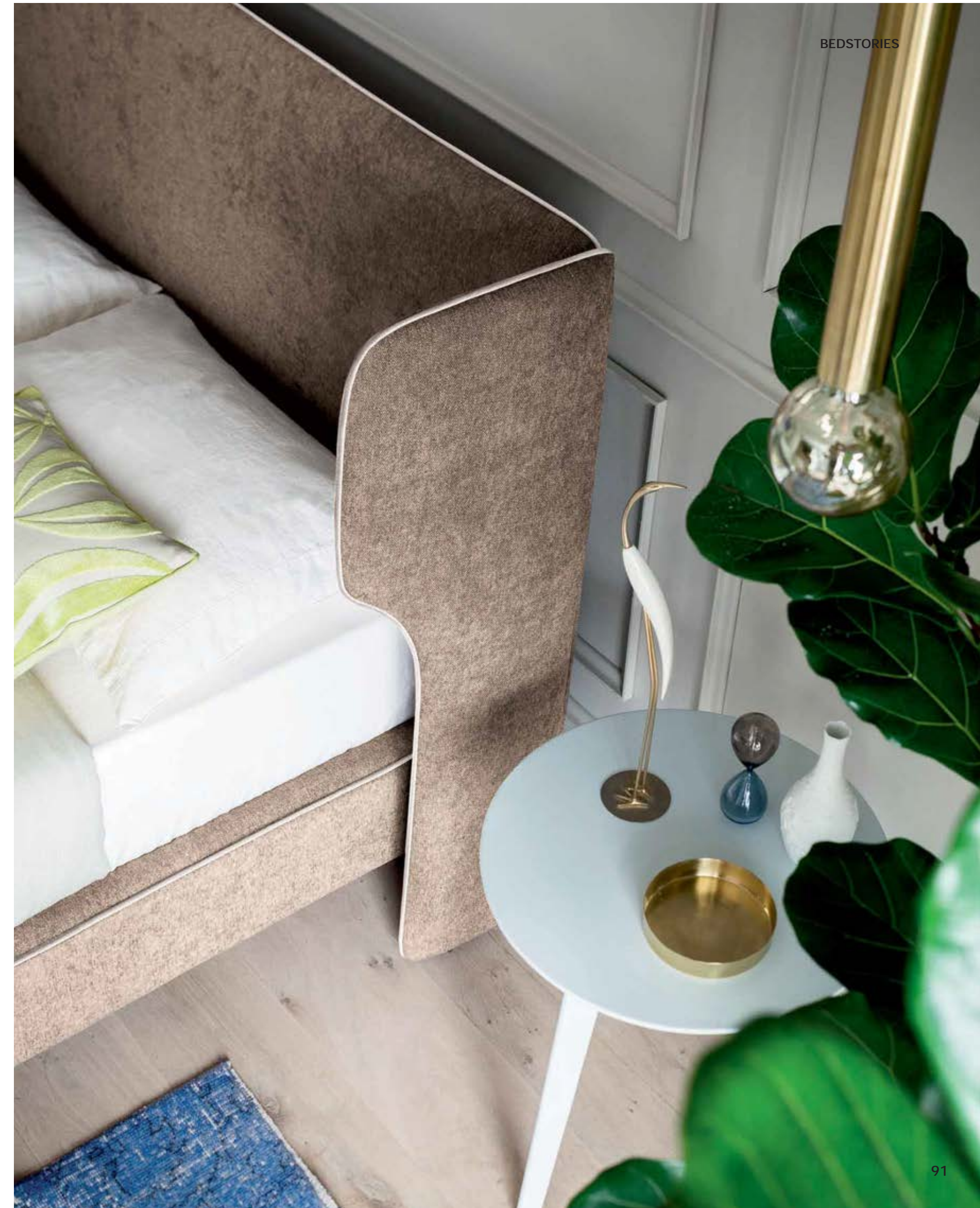







Il bordino in rilievo aggiunge un pregio artigianale alla realizzazione, rivelando una grande cura per ogni dettaglio.

The relief edge piping adds a hand-finished-quality touch to the product, showing the care taken with every detail.

Le bord en relief ajoute une touche de qualité artisanale à la réalisation, en révélant un grand soin pour le moindre détail.

Die abgesetzte Kante verleiht dem Modell eine besondere handwerkliche Note, die viel Liebe zum Detail erkennen lässt.





# Spencer

COMPLETAMENTE SFODERABILE / COMPLETELY REMOVABLE FABRIC / COMPLÈTEMENT DÉHOUSSABLE / VOLLSTÄNDIG ABZIEHBAR

**MASSELLI** in legno di abete e/o scatolati in multistrato di legno di pioppo.

**PANNELLI** da 18/25 mm in particelle di legno in classe E1 a bassa emissione di formaldeide e fibra di legno naturale.

**ESPANSI** di poliuretano indeformabile a portanza differenziata, densità da 18 kg/mc a 40 kg/mc.

**PRIMO RIVESTIMENTO** in espanso di poliestere accoppiato a caldo a vellutino aggrappante in poliestere e/o ovatta di poliestere al 100% da 200gr.

**PANNELLI FONDO** contenitore da 12-14 mm in particelle di legno di pioppo in classe E1.

**FORGINGS** fir wood, and/or boxed in poplar plywood.

**PANELS** 18/25 mm in poplar wood particles class E1 low formaldehyde emission and natural wood fiber.

**POLYURETHANE FOAM**, crushproof, of different capacity, density from 18 kg/mc to 40 kg/mc.

**FIRST COATING** hot bonded polyester foam, velvet adhesion in polyester and/or 100% polyester wool, 200gr.

**CONTAINER BOTTOM** panels 12-14 mm in poplar wood particles class E1.

**TIGE** en pin et/ou boitiers en multicouche en bois de peuplier.

**PANNEAUX** de 18/25 mm en particules de bois de peuplier classe E1 à faible émission de formaldéhyde et fibre de bois naturelle.

**POLYURÉTHANE EXPANSÉ** indéformable à portée différenciée, densité de 18kg/m<sup>3</sup> à 40kg/m<sup>3</sup>.

**PREMIER REVÊTEMENT** en polyester expansé accouplé à chaud à un velours accrochant en polyester et/ou ouate de polyester à 100% de 200g.

**PANNEAUX DE FOND COFFRE RANGEMENT** de 12-14mm en particules de bois de peuplier classe E1.

**MASSIVES** Tannenholz und/oder Blöcke aus Pappelmeerschichholz.

**SPANPLATTEN** aus Pappelholz mit 18/25 mm Schichtdicke der Klasse E1, geringer Formaldehydabgabe und natürlichen Holzfasern.

**POLYURETHANSCHAUM**, nicht verformbar und mit differenzierter Tragfähigkeit, Dichten von 18 kg/m<sup>3</sup> bis 40 kg/m<sup>3</sup>.

**ERSTER ÜBERZUG** aus Polyesterschaum, der auf Polyester-Samt und/oder 100% Polyesterwatte (zu 200 g) heiß aufkaschiert wurde.

**BODENPLATTEN** des Bettkastens aus 12-14 mm starken Spanplatten aus Pappelholz der Klasse E1.



Spessore testiera 7 cm  
Headboard thickness 7 cm  
Épaisseur tête de lit 7 cm  
Stärke des Kopfteils 7 cm



Elemento testiera mobile e removibile  
Headboard element mobile and removable  
Élément tête de lit mobile et amovible  
Mobiles und abnehmbares Kopfteilelement

## RING SMART

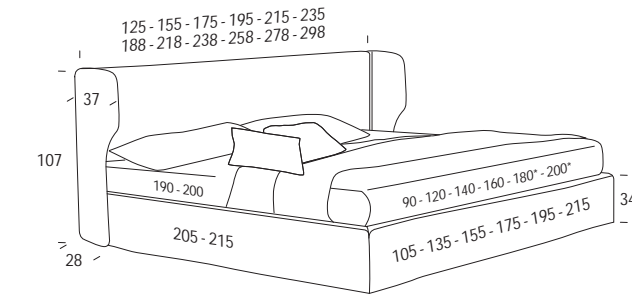

\* Rete L. 180 e L. 200 cm solo profondità 200 cm / Support W. 180 and W. 200 cm only D 200 cm / Sommier L. 180 et L. 200 cm uniquement en profondeur 200 cm / Attenrost B. 180 und B. 200 cm nur mit Tiefe 200 cm

Standard BASIC H 3

Pag 545

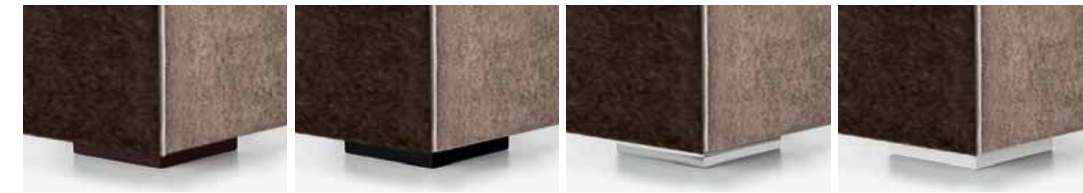

Wengé / Wengé / Wengé / Wengé

Nero / Black / Noir / Schwarz

Argento / Silver / Argent / Silber

Bianco / White / Blanc / Weiß

Optional LUX H 3

Pag 545



Wengé / Wengé / Wengé / Wengé

Nero / Black / Noir / Schwarz

Cromo / Chrome / Chrome / Chrom

Bianco / White / Blanc / Weiß

## RING YORK

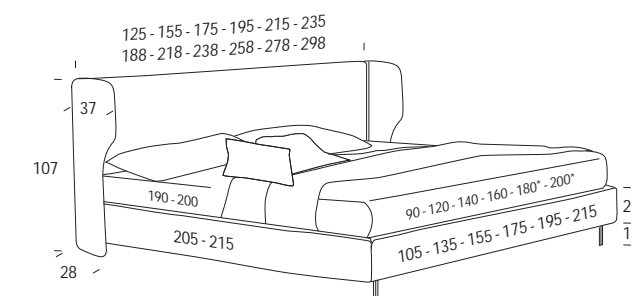

\* Rete L. 180 e L. 200 cm solo profondità 200 cm / Support W. 180 and W. 200 cm only D 200 cm / Sommier L. 180 et L. 200 cm uniquement en profondeur 200 cm / Attenrost B. 180 und B. 200 cm nur mit Tiefe 200 cm

PIEDE TWINNY a doppio stiletto H 13 / Double stiletto Twinny foot H 13

PIEDE BAOBAB in legno H 13 / Baobab wooden feet H 13

Pag 544 / Pied Baobab en bois H 13 / Fußmodell Baobab aus Holz H13 Pag 544



Cromo lucido  
Shining chrome  
Chrome brillant  
Chrom Hochglanz

Carbon look lucido  
Shining carbon look  
Carbon look brillant  
Carbon-Look Hochglanz

Nero opaco  
Mat black  
Noir mat  
Mattschwarz

Rovere Londra  
Dak "Londra"  
Chêne "Londra"  
Eiche "Londra"

Rovere tabacco  
Dak "tabacco"  
Chêne "tabacco"  
Eiche "tabacco"

Rovere naturale  
Dak "naturale"  
Chêne "naturale"  
Eiche "naturale"

## Optional

Rete / Support / Sommier / Lattenrost Pag 548

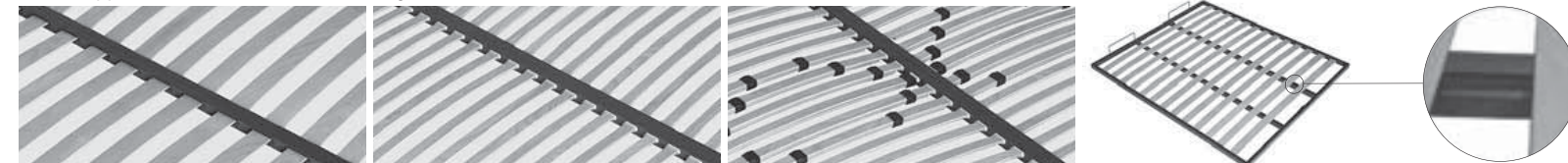

Armony (Standard)

Thai

46 doghe  
46 slats  
46attes  
46 Leisten

Energy

Non applicabile a rete da 120 cm  
Not applicable to 120 cm support  
Non applicable au sommier de 120 cm  
Gilt nicht für Lattenrost zu 120 cm

Doppio Flip

Solo 140/160x190/200 - 180x200  
Only 140/160x190/200 - 180x200  
Uniquement 140/160x190/200 - 180x200  
Nur 140/160x190/200 - 180x200

Pag 552



Sacco contenitore multiuso  
Multipurpose storage bag  
Sac coffre de rangement multi usage  
Mehrzweck-Aufbewahrungstasche

Pag 553



Tessuto coprirete traspirante antipolvere  
Support cover fabric breathable and dustproof  
Tissu couvre-sommier transpirant anti-poussière  
Atmungsaktives, vor Staub schützendes Gewebe

Pag 557



Regolatore altezza rete solo per reti in appoggio  
Support height adjuster only for resting frames  
Réglage hauteur sommier uniquement pour sommiers à poser  
Lattenrost-Höhenverstellung nur für aufliegende Lattenroste

Pag 556



Clean Up System

# Paris



L'ampia testiera imbottita, si contraddistingue per le forme arrotondate dei suoi terminali sottolineate dal bordo a contrasto.

The imposing, upholstered headboard is characterised by rounded end panels, outlined with contrasting piping.

L'ample tête de lit rembourrée se distingue pour les formes arrondies de ses éléments terminaux soulignés par le bord en contraste.

Das große gepolsterte Kopfteil zeichnet sich durch die abgerundeten Formen seiner Abschlusselemente aus, die durch die farblich abgesetzte Bordüre betont werden.







Il bordo in contrasto incornicia le linee del giroletto e della testiera.

The contrasting piping frames the individual elements making up the bed frame and headboard.

Le bord en contraste encadre les lignes du cadre et de la tête de lit.

Die farblich abgesetzte Bordüre rahmt die Linienführungen von Bettrahmen und Kopfteil ein.

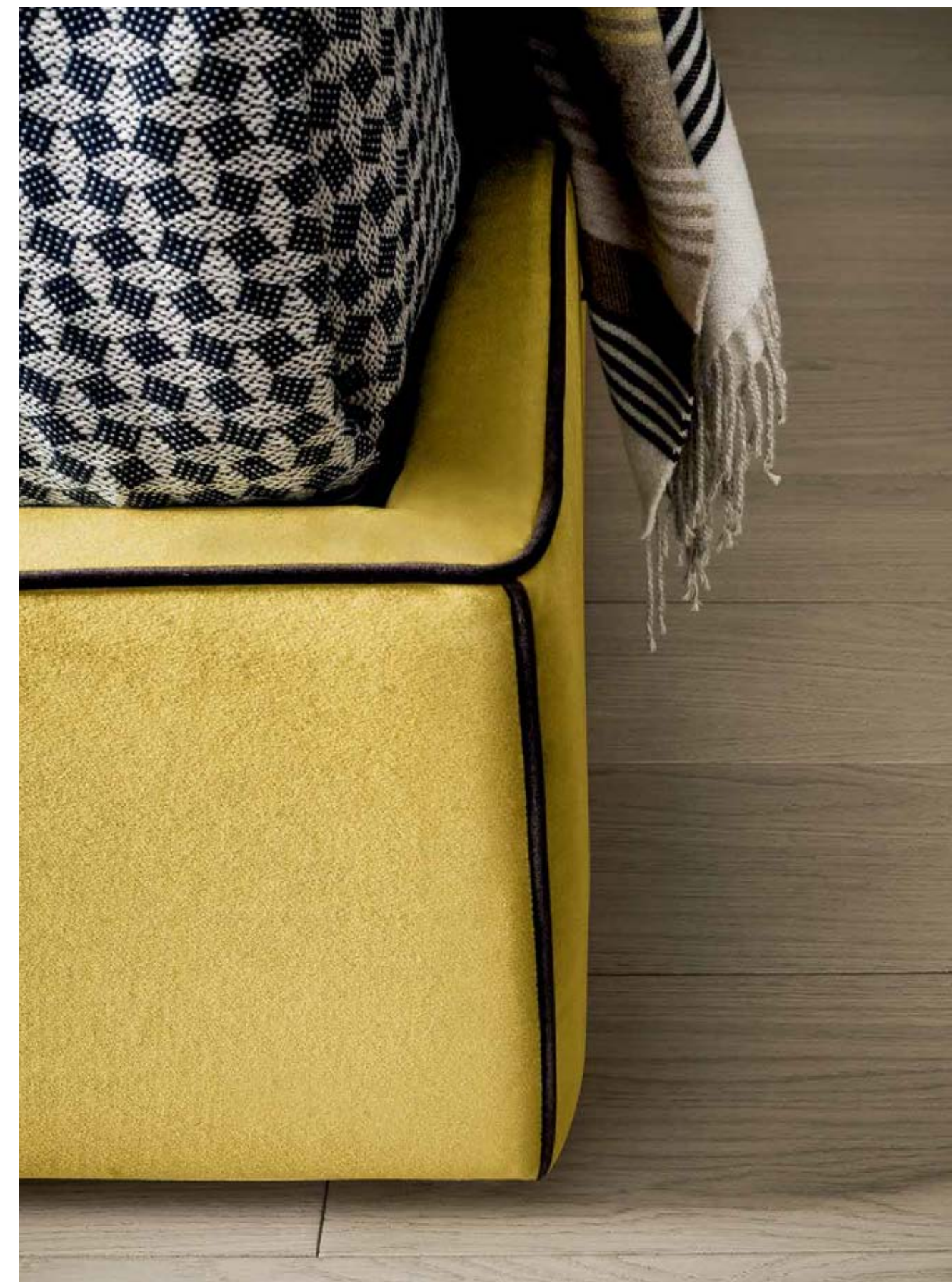



# Paris

COMPLETAMENTE SFODERABILE / COMPLETELY REMOVABLE FABRIC / COMPLÈTEMENT DÉHOUSSABLE / VOLLSTÄNDIG ABZIEHBAR

**MASSELLI** in legno di abete e/o scatorlati in multistrato di legno di pioppo.

**PANNELLI** da 18/25 mm in particelle di legno in classe E1 a bassa emissione di formaldeide e fibra di legno naturale.

**ESPANSI** di poliuretano indeformabile a portanza differenziata, densità da 18 kg/mc a 40 kg/mc.

**PRIMO RIVESTIMENTO** in espanso di poliestere accoppiato a caldo a vellutino aggrappante in poliestere e/o ovatta di poliestere al 100% da 200gr.

**PANNELLI FONDO** contenitore da 12-14 mm in particelle di legno di pioppo in classe E1.

**FORGINGS** fir wood, and/or boxed in poplar plywood.

**PANELS** 18/25 mm in poplar wood particles class E1 low formaldehyde emission and natural wood fiber.

**POLYURETHANE FOAM**, crushproof, of different capacity, density from 18 kg/mc to 40 kg/mc.

**FIRST COATING** hot bonded polyester foam, velvet adhesion in polyester and/or 100% polyester wool, 200gr.

**CONTAINER BOTTOM** panels 12-14 mm in poplar wood particles class E1.

**TIGE** en pin et/ou boitiers en multicouche en bois de peuplier.

**PANNEAUX** de 18/25 mm en particules de bois de peuplier classe E1 à faible émission de formaldéhyde et fibre de bois naturelle.

**POLYURÉTHANE EXPANSÉ** indéformable à portée différenciée, densité de 18kg/m<sup>3</sup> à 40kg/m<sup>3</sup>.

**PREMIER REVÊTEMENT** en polyester expansé accouplé à chaud à un velours accrochant en polyester et/ou ouate de polyester à 100% de 200g.

**PANNEAUX DE FOND COFFRE RANGEMENT** de 12-14mm en particules de bois de peuplier classe E1.

**MASSIVES** Tannenholz und/oder Blöcke aus Pappelmeerschichholz.

**SPANPLATTEN** aus Pappelholz mit 18/25 mm Schichtdicke der Klasse E1, geringer Formaldehydabgabe und natürlichen Holzfasern.

**POLYURETHANSCHAUM**, nicht verformbar und mit differenzierter Tragfähigkeit, Dichten von 18 kg/m<sup>3</sup> bis 40 kg/m<sup>3</sup>.

**ERSTER ÜBERZUG** aus Polyesterschaum, der auf Polyester-Samt und/oder 100% Polyesterwatte (zu 200 g) heiß aufkaschiert wurde.

**BODENPLATTEN** des Bettkastens aus 12-14 mm starken Spanplatten aus Pappelholz der Klasse E1.



Spessore testiera 7 cm  
Headboard thickness 7 cm  
Épaisseur tête de lit 7 cm  
Stärke des Kopfteils 7 cm

## Optional

Rete / Support / Sommier / Lattenrost Pag 548

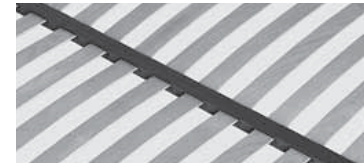

**Armony**  
(Standard)

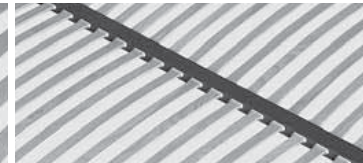

**Thai**  
46 doghe  
46 slats  
46attes  
46 Leisten

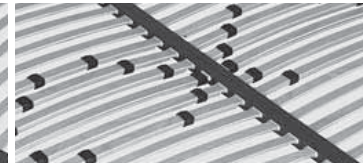

**Energy**  
Non applicabile a rete da 120 cm  
Not applicable to 120 cm support  
Non applicable au sommier de 120 cm  
Gilt nicht für Lattenrost zu 120 cm

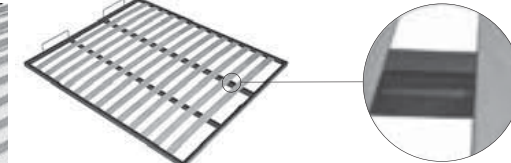

**Doppio Flip**  
Solo 140/160x190/200 - 180x200  
Only 140/160x190/200 - 180x200  
Uniquement 140/160x190/200 - 180x200  
Nur 140/160x190/200 - 180x200

Pag 552



**Sacco contenitore multiuso**  
Multipurpose storage bag  
Sac coffre de rangement multi usage  
Mehrzweck-Aufbewahrungstasche

Pag 553



**Tessuto coprirete traspirante antipolvere**  
Support cover fabric breathable and dustproof  
Tissu couvre-sommier transpirant anti-poussière  
Atmungsaktives, vor Staub schützendes Gewebe

Pag 557



**Regolatore altezza rete solo per reti in appoggio**  
Support height adjuster only for resting frames  
Réglage hauteur sommier uniquement pour sommiers à poser  
Lattenrost-Höhenverstellung nur für aufliegende Lattenroste

Pag 556



**Clean Up System**



**Elemento testiera mobile e removibile**  
Headboard element mobile and removable  
Élément tête de lit mobile et amovible  
Mobiles und abnehmbares Kopfteilelement

## RING SMART

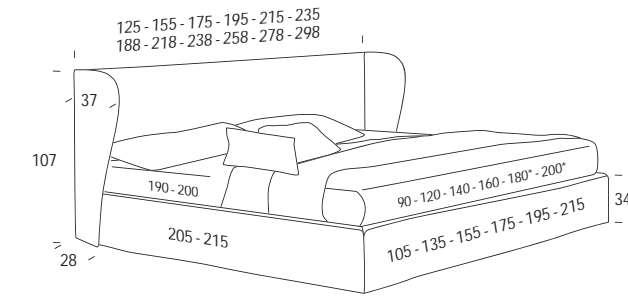

\* Rete L. 180 e L. 200 cm solo profondità 200 cm / Support W. 180 and W. 200 cm only D 200 cm  
/ Sommier L. 180 et L. 200 cm uniquement en profondeur 200 cm / Attenrost B. 180 und B. 200 cm nur mit Tiefe 200 cm

Standard BASIC H 3 Pag 545



Wengé / Wengé / Wengé / Wengé



Nero / Black / Noir / Schwarz



Argento / Silver / Argent / Silber



Bianco / White / Blanc / Weiß

Optional LUX H 3 Pag 545



Wengé / Wengé / Wengé / Wengé



Nero / Black / Noir / Schwarz



Cromo / Chrome / Chrome / Chrom



Bianco / White / Blanc / Weiß

## RING YORK

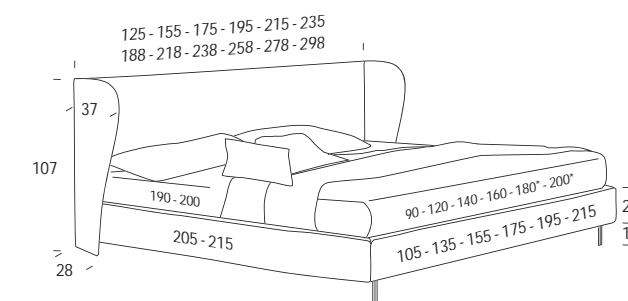

\* Rete L. 180 e L. 200 cm solo profondità 200 cm / Support W. 180 and W. 200 cm only D 200 cm  
/ Sommier L. 180 et L. 200 cm uniquement en profondeur 200 cm / Attenrost B. 180 und B. 200 cm nur mit Tiefe 200 cm

PIEDE TWINNY a doppio stiletto H 13 / Double stiletto Twinny foot H 13

PIEDE BAOBAB in legno H 13 / Baobab wooden feet H 13



**Cromo lucido**  
Shining chrome  
Chrome brillant  
Chrom Hochglanz

**Carbon look lucido**  
Shining carbon look  
Carbon look brillant  
Carbon-Look Hochglanz

**Nero opaco**  
Mat black  
Noir mat  
Mattschwarz

**Rovere Londra**  
Dak "Londra"  
Chêne "Londra"  
Eiche "Londra"

**Rovere tabacco**  
Dak "tabacco"  
Chêne "tabacco"  
Eiche "tabacco"

**Rovere naturale**  
Dak "naturale"  
Chêne "naturale"  
Eiche "naturale"

Optional Pag 550

Meccanica / Mechanism  
/ Mécanique / Mechanisch

Dynamic

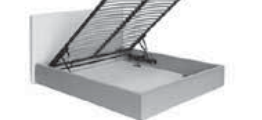

Maverick

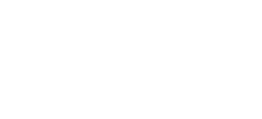

Pag 544

Meccanica / Mechanism  
/ Mécanique / Mechanisch

Dynamic



Maverick

Pag 544

Meccanica / Mechanism  
/ Mécanique / Mechanisch

Dynamic



Maverick



# Relax Collection

Per chi crede che oggi il vero lusso sia il tempo, e sa che ogni momento libero merita di essere vissuto intensamente. Relax Collection è la risposta a una domanda di benessere, anzi a diverse modalità di intenderlo: basta reclinare i cuscini della testiera per provare un nuovo comfort, ideale per chi voglia leggere o guardare la TV a letto. Completano la proposta i numerosi optional, pratici e studiati in ogni dettaglio.

For those who think that time is the real luxury and know that every spare moment deserves to be lived intensely. Relax Collection is the answer to a demand of well-being, actually to different ways of understanding it: all you need is to recline the headboard cushions to feel a new comfort, the ideal for those wanting to read or watch TV at bed. The suggestion is completed by many handy optionals, cared for in every detail.

Pour ceux qui croient qu'aujourd'hui le vrai luxe est le temps, et ceux qui savent que chaque instant libre mérite d'être vécu intensément. Relax Collection est la réponse à une recherche de bien-être, plutôt à différentes modalités de le comprendre: il suffit de récliner les coussins de la tête de lit pour goûter à un nouveau confort, idéal pour ceux qui veulent lire ou regarder la télévision au lit. De nombreuses options complètent cette offre, pratiques et étudiées en détail.

Für alle, die glauben, dass der wahre Luxus von heute die Zeit ist, und die wissen, dass jeder freie Moment es verdient, intensiv gelebt zu werden. Die Relax Collection ist die Antwort auf das Bedürfnis nach Wohlbefinden, oder besser gesagt, nach einem anderen Verständnis davon: Legen Sie einfach die Kopfteilkissen zurück, um einen neuen Komfort zu erleben, ideal für diejenigen, die im Bett lesen oder fernsehen möchten. Das Angebot wird durch zahlreiche optionale, praktische und bis ins Detail durchdachte Extras ergänzt.

# Luis

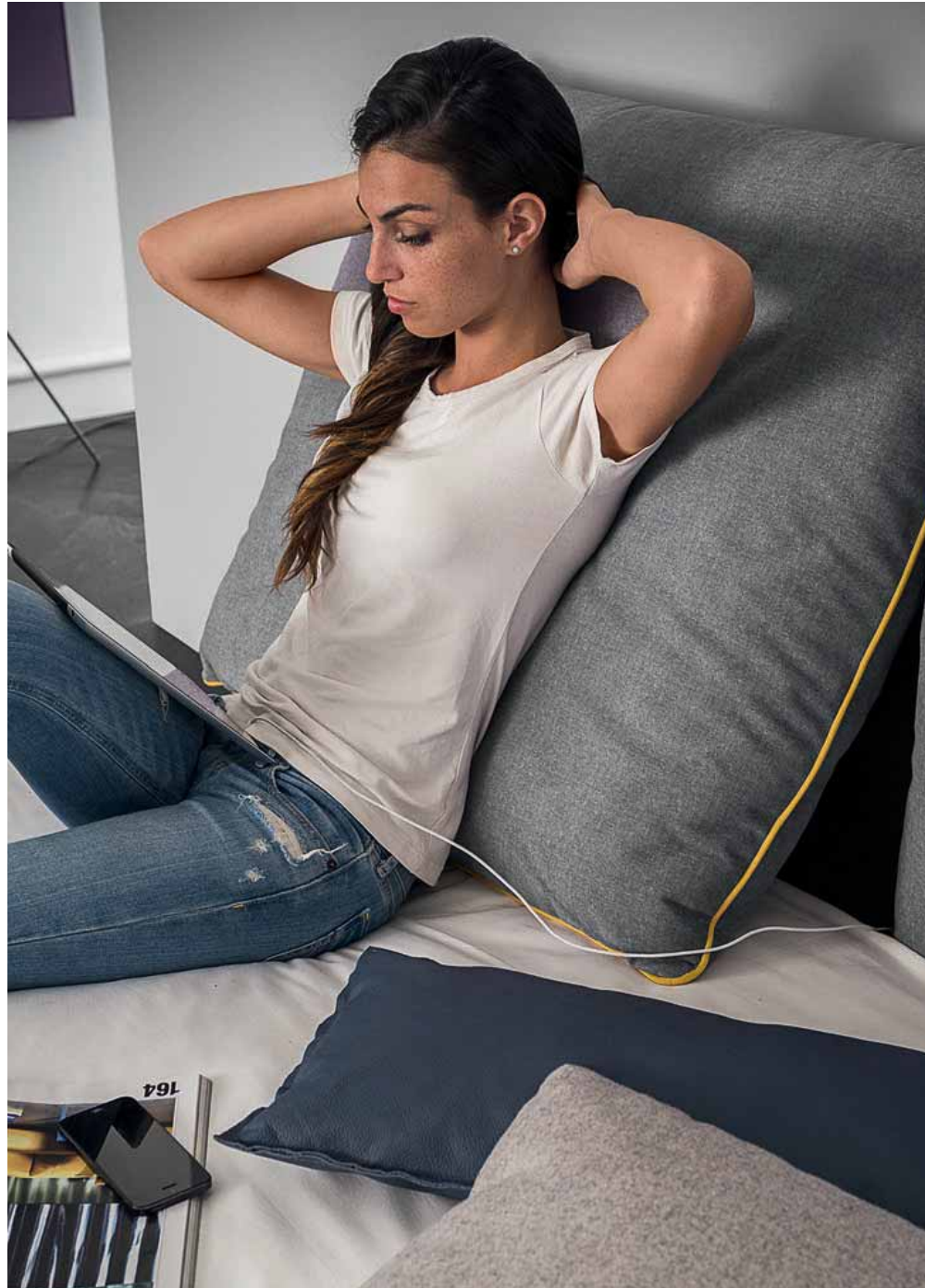

Linee pulite e dolcemente arrotondate, bordi eleganti che donano dinamicità e mettono in risalto il design di questo modello. Luis si presenta esuberante con i suoi particolari mai banali.

Clean lines gently rounded, stylish trims giving dynamism and highlighting the design of this model. Luis is lively with its never trivial details.

Lignes propres et doucement arrondies, aux bords élégants qui offrent dynamisme et mettent en relief le design de ce modèle. Luis se présente comme exubérant avec ses particuliers qui ne sont jamais banaux.

Saubere und sanft abgerundete Linien, elegante Kanten, die Dynamik verleihen und das Design dieses Modells hervorheben. Luis ist überschwänglich mit seinen nie trivialen Details.

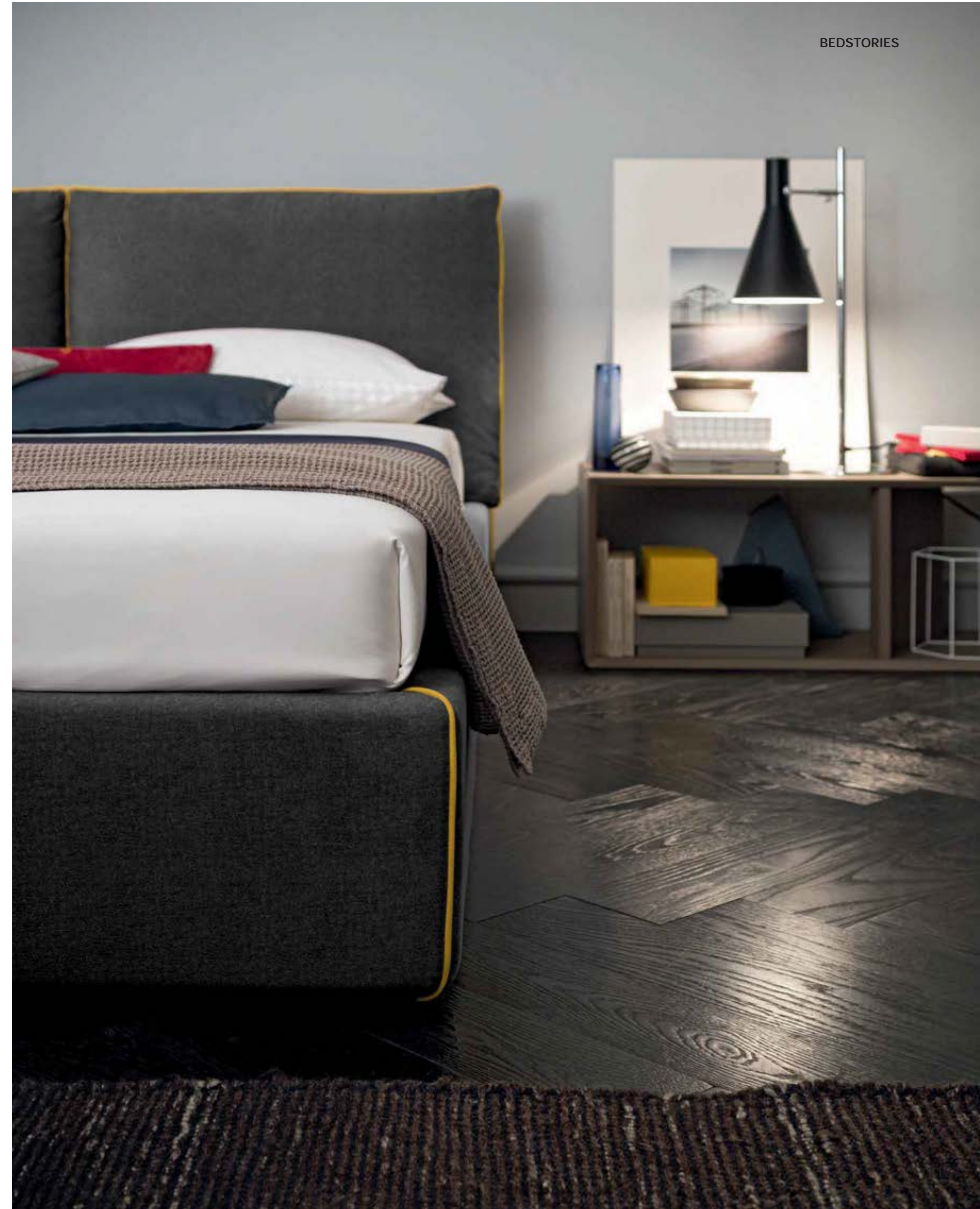

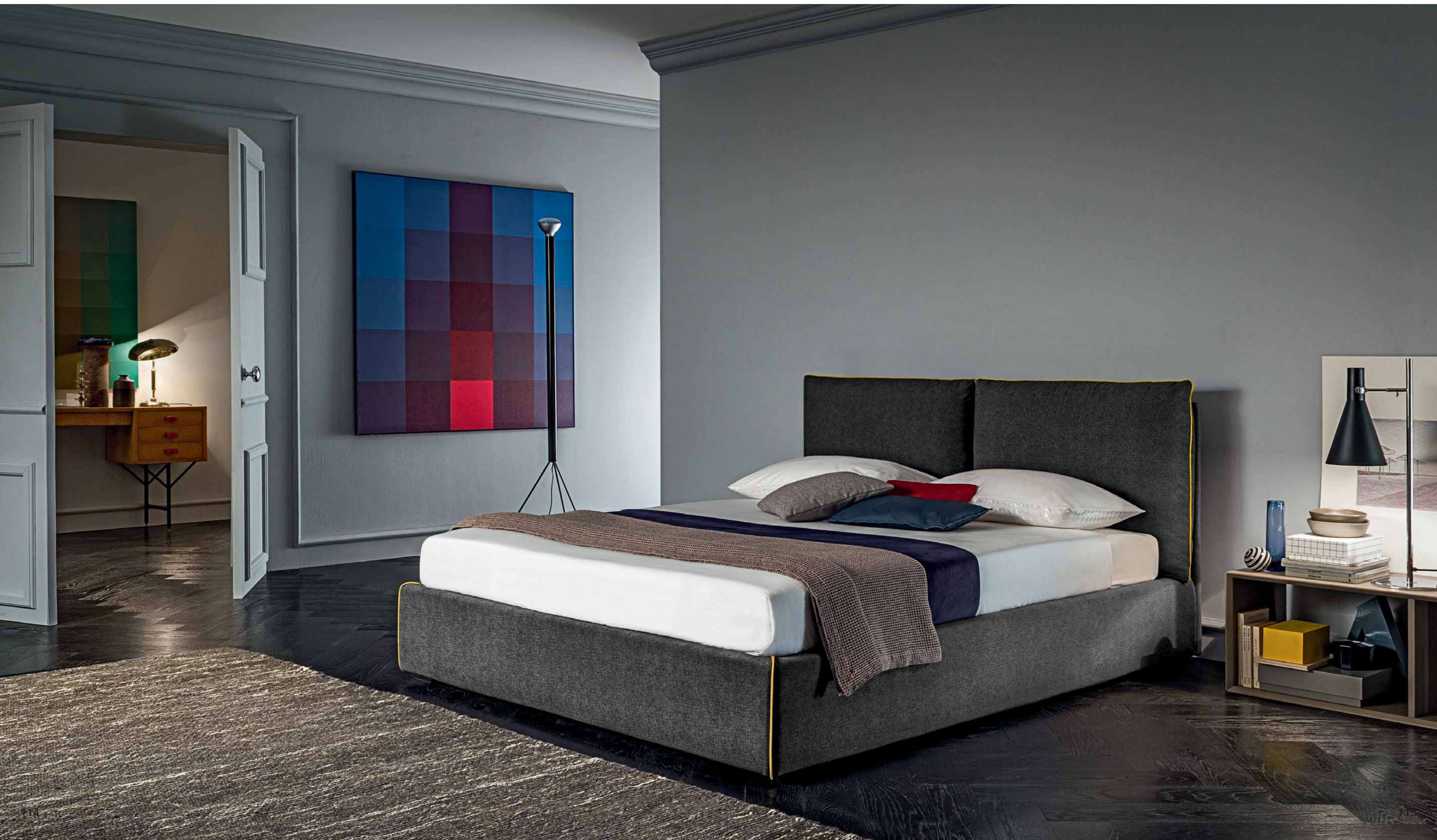



Relax System  
Grazie all'innovativa soluzione dei cuscini reclinabili le testiere sono relax system, consentono cioè una comoda posizione "seduta" e un pratico appoggio di sostegno per leggere, guardare la tv, lavorare al laptop...

Relax System  
With the innovative solution of the headboard cushions, many headboards become relaxation systems, that is, allow a comfortable position while "sitting" and a practical support for reading, watching TV, working on laptop...

Relax System  
Grâce à la solution innovante des coussins tête de lit inclinable, de nombreuses tête de lits sont « relax system », elles permettent d'avoir une position assise commode et un appui pratique pour lire, regarder la télé, travailler avec l'ordinateur portable...

Relax System  
Dank der innovativen Lösung mit neigbaren Kissen werden die Kopfteile zu einem Relax-System, das eine bequeme „Sitzposition“ bietet und den Rücken beim Lesen, Fernsehen, Arbeiten am Laptop gut abstützt...

## Relax System

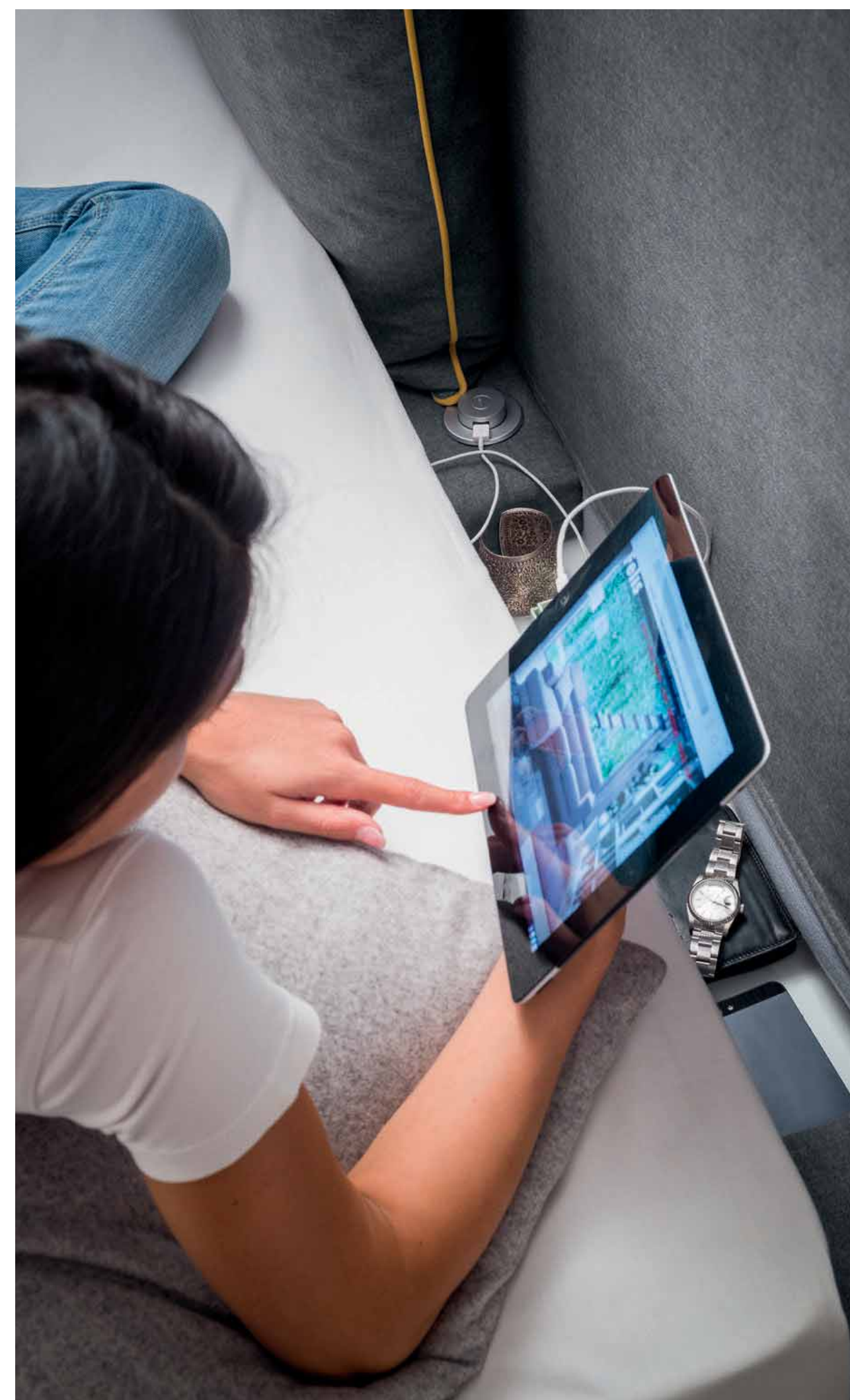

Le piccole gioie, il telefono, l'orologio: i tanti oggetti quotidiani trovano posto nei portaoggetti alla base della testiera. Una soluzione pratica per averli sempre in ordine e a portata di mano. Le nicchie sono attrezzabili anche con una torretta caricabatteria: basta una leggera pressione per farla uscire e, una volta utilizzata, scompare.

The small jewels, the smartphone, the watch: the many everyday items are placed in the storage bag at the base of the headboard. A practical solution to have them always in order and at hand. The niches may be also equipped with a battery charger: just a slight pressure to get it out and, when used, it disappears.

Les petites joies, le téléphone, la montre: tant d'objets quotidiens qui trouvent leur place dans le porte-objet à la base de la tête de lit. Une solution pratique pour les avoir toujours en ordre et à portée de main. Les niches peuvent également être équipées d'une petite tour charge-batteries: il suffit d'une légère pression pour la faire sortir et, une fois utilisée, elle disparaît.

All die netten Kleinigkeiten, das Telefon, die Uhr: viele Alltagsgegenstände finden ihren Platz in den Ablagemöglichkeiten an der Basis des Kopfteils. Eine praktische Lösung, um sie ordentlich verstaut und griffbereit zu halten. Die Nischen können auch mit einer Batterieladestation ausgestattet werden: ein leichter Druck genügt, um sie herauszuholen, und nach der Benutzung verschwindet sie wieder.

L'eleganza della semplicità.  
Il cordoncino in colore a  
contrasto sui bordi dei  
grandi cuscini della testiera  
e sugli angoli di giunzione  
al piede del giroletto.

The elegance of simplicity.  
The cord with a contrasting  
color on the edges of  
the big pillows on the  
headboard and on the  
corners at the foot of the  
bed frame.

L'élégance de la simplicité.  
Le cordon de couleur  
contrastée sur les bords  
des grands coussins de la  
tête de lit et sur les angles  
de jonction au pied du tour  
de lit.

Schlichte Eleganz.  
Hierfür sorgt eine farblich  
abgesetzte Bordüre an  
den Rändern der großen  
Kissen des Kopfteils und an  
den Verbindungsecken am  
Fußende des Bettrahmens.



# Luis

COMPLETAMENTE SFODERABILE / COMPLETELY REMOVABLE FABRIC / COMPLÈTEMENT DÉHOUSSABLE / VOLLSTÄNDIG ABZIEHBAR

**MASSELLI** in legno di abete e/o scatorlati in multistrato di legno di pioppo.

**PANNELLI** da 18/25 mm in particelle di legno di pioppo in classe E1 a bassa emissione di formaldeide e fibra di legno naturale.

**ESPANSI** di poliuretano in densità da 18 kg/mc a 40 kg/mc. Cuscini rivestiti in ovatta da 300 gr.

**PRIMO RIVESTIMENTO** in espanso di poliestere accoppiato a caldo a vellutino aggrappante in poliestere e/o ovatta di poliestere al 100% da 200gr.

**PANNELLI FONDO** contenitore da 12-14 mm in particelle di legno di pioppo in classe E1.

**FORGINGS** fir wood, and/or boxed in poplar plywood.

**PANELS** 18/25 mm in poplar wood particles class E1 low formaldehyde emission and natural wood fiber.

**POLYURETHANE FOAM** density from 18 kg/mc to 40 kg/mc. Cushions coated with 300 gr wadding.

**FIRST COATING** hot bonded polyester foam, velvet adhesion in polyester and/or 100% polyester wool, 200gr.

**CONTAINER BOTTOM** panels 12-14 mm in poplar wood particles class E1.

**TIGE** en pin et/ou boitiers en multicouche en bois de peuplier.

**PANNEAUX** de 18/25 mm en particules de bois de peuplier classe E1 à faible émission de formaldéhyde et fibre de bois naturelle.

**POLYURÉTHANE EXPANSÉ** densité de 18kg/m<sup>3</sup> à 40kg/m<sup>3</sup>. Coussin rembourrés avec de la ouate de 300g.

**PREMIER REVÊTEMENT** en polyester expansé accouplé à chaud à un velours accrochant en polyester et/ou ouate de polyester à 100% de 200g.

**PANNEAUX DE FOND COFFRE** rangement de 12-14mm en particules de bois de peuplier classe E1.

**MASSIVES** Tannenholz und/oder Blöcke aus Pappelmeerschichholz.

**SPANPLATTEN** aus Pappelholz mit 18/25 mm Schichtdicke der Klasse E1, geringer Formaldehydabgabe und natürlichen Holzfasern.

**POLYURETHANSCHAUM** mit Dichten von 18 kg/m<sup>3</sup> bis 40 kg/m<sup>3</sup>. Kissen mit Watte zu 300 g überzogen.

**ERSTER ÜBERZUG** aus Polyesterschaum, der auf Polyester-Samt und/oder 100% Polyesterwatte (zu 200 g) heiß aufkaschiert wurde.

**BODENPLATTEN** des Bettkastens aus 12-14 mm starken Spanplatten aus Pappelholz der Klasse E1.



Portagioie  
Jewelry Box  
Parte-bijoux  
Schmuckkästchen  
p. 542



Porta USB  
USB holder  
Port USB  
USB-Anschluss  
p. 543

## Optional

Rete / Support / Sommier / Lattenrost Pag 548

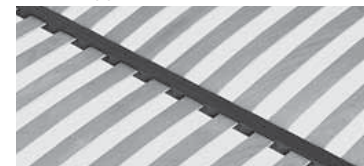

Armony  
(Standard)

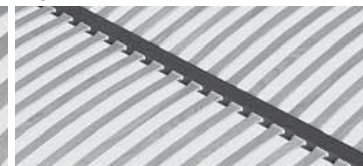

Thai  
46 doghe  
46 slats  
46 attes  
46 Leisten

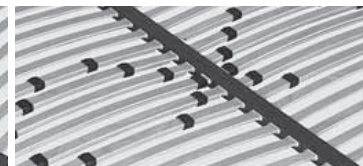

Energy  
Non applicabile a rete da 120 cm  
Not applicable to 120 cm support  
Non applicable au sommier de 120 cm  
Gilt nicht für Lattenrost zu 120 cm

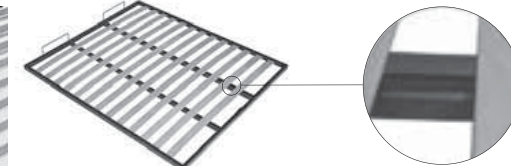

Doppio Flip  
Solo 140/160x190/200 - 180x200  
Only 140/160x190/200 - 180x200  
Uniquement 140/160x190/200 - 180x200  
Nur 140/160x190/200 - 180x200

Pag 552



Sacco contenitore multiuso  
Multipurpose storage bag  
Sac coffre de rangement multi usage  
Mehrzweck-Aufbewahrungstasche

Pag 553



Tessuto coprirete traspirante antipolvere  
Support cover fabric breathable and dustproof  
Tissu couvre-sommier respirant anti-poussière  
Atmungsaktives, vor Staub schützendes Gewebe

Pag 557



Regolatore altezza rete solo per reti in appoggio  
Support height adjuster only for resting frames  
Règlage hauteur sommier uniquement pour sommiers à poser  
Lattenrost-Höhenverstellung nur für aufliegende Lattenroste

Pag 556



Clean Up System

## RELAX SYSTEM

### RING EKO



### RING LIBERTY



Gonna in tinta  
Skirt in matching colour  
Jupe en teinte  
Ton-in-Ton ausgeführter Volant



Gonna a contrasto  
Skirt contrasting  
Jupe en contraste  
Farblich abgesetzter Volant

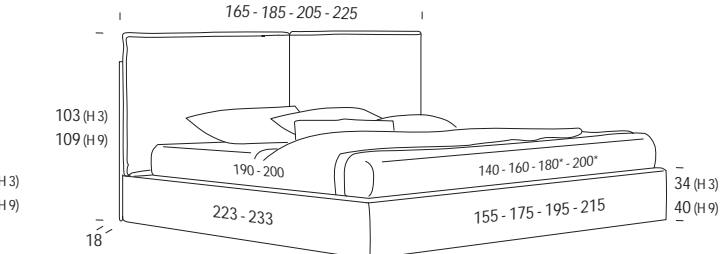
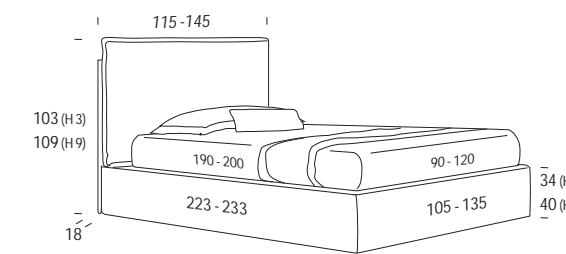

\* Rete L. 180 e L. 200 cm solo profondità 200 cm / Support W. 180 and W. 200 cm only D 200 cm  
/ Sommier L. 180 et L. 200 cm uniquement en profondeur 200 cm / Attenrost B. 180 und B. 200 cm nur mit Tiefe 200 cm

Standard BASIC H 3 Pag 545



Wengé / Wengé  
/ Wengé / Wengé

Pag 545



Nero / Black  
/ Noir / Schwarz

Optional LUX H 3 Pag 545



Wengé / Wengé  
/ Wengé / Wengé

Pag 545



Nero / Black  
/ Noir / Schwarz

Optional VISUAL H 9 Pag 545



Wengé / Wengé  
/ Wengé / Wengé

Pag 545



Nero / Black  
/ Noir / Schwarz

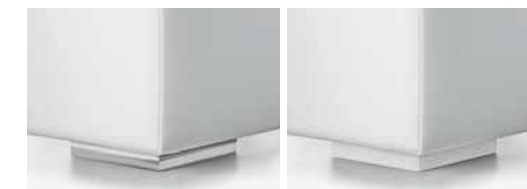

Argento / Silver  
/ Argent / Silber



Bianco / White  
/ Blanc / Weiß



Cromo / Chrome  
/ Chrome / Chrom



Bianco / White  
/ Blanc / Weiß



Argento / Silver  
/ Argent / Silber



Bianco / White  
/ Blanc / Weiß

## Optional Pag 550

Meccanica / Mechanism  
/ Mécanique / Mechanisch

Dynamic



Maverick



# Scotty - A/B



Scotty presenta due grandi cuscini in formato testiera. Il bordo a contrasto ha un impatto estetico inequivocabile e forte: delinea i bordi dei cuscini e della struttura del letto, ricreano un dettaglio stilistico e sartoriale brioso.

Scotty's headboard is formed by two large cushions. The contrasting trim gives it a bold, unmistakable aesthetic by outlining the contours of the cushions and bed frame and recreating a lively, stylish, tailored detail.

Scotty présente deux grands coussins sous une forme de tête de lit. Le bord en contraste a un impact esthétique clair et fort: il dessine les bords des coussins et de la structure du lit, et recrée un détail stylé et haute couture animé.

Scotty präsentiert zwei große Kissen im Kopfteilformat. Die farblich abgesetzte Bordüre hat eine unverwechselbare und beeindruckende ästhetische Wirkung: sie grenzt die Ränder der Kissen und der Bettstruktur ab und schafft so ein spritziges stilistisches und handwerkliches Detail.



RELAX COLLECTION



Scotty - A





Relax System  
 Grazie all'innovativa soluzione dei cuscini reclinabili molte testiere sono relax system, consentono cioè una comoda posizione "seduta" e un pratico appoggio di sostegno per leggere, guardare la tv, lavorare al laptop...

Relax System  
 With the innovative solution of the headboard cushions, many headboards become relaxation systems, that is, allow a comfortable position while "sitting" and a practical support for reading, watching TV, working on laptop...

Relax System  
 Grâce à la solution innovante des coussins tête de lit inclinable, de nombreuses tête de lits sont « relax system », elles permettent d'avoir une position assise commode et un appui pratique pour lire, regarder la télé, travailler avec l'ordinateur portable...

Relax System  
 Dank der innovativen Lösung mit neigbaren Kissen werden viele Kopfteile zu einem Relax-System, bieten eine bequeme „Sitzposition“ und stützen den Rücken beim Lesen, Fernsehen, Arbeiten am Laptop...

# Scotty - A



I bottoni possono essere in tinta con il tessuto di base, o a contrasto, dettaglio che renderà unico il letto.

The buttons may be matching or contrasting the basic fabric colour, a detail which will give this bed a uniqueness air.

Les boutons peuvent être en teinte avec le tissu de base, ou en contraste, détail qui rendra votre lit unique.

Die Knöpfe können in der gleichen Farbe wie der Grundstoff oder in einer Kontrastfarbe gewählt werden - ein Detail, das das Bett einzigartig macht.

# Scotty - B



Mentre i bottoni tendono alla tradizione, il cordoncino rende i cuscini più freschi e attuali. Divertendosi con i contrasti si possono creare giochi di luce che sottolineano la ricca imbottitura.

While the buttons reflect the tradition, the piping makes the cushions more contemporary and fresher. Playing on the contrasts you can create tricks of light which emphasize the rich padding.

Tandis que les boutons rappellent la tradition, le petit cordonnet rend les coussins plus frais et actuels. En s'amusant avec les contrastes nous créons des jeux de lumières qui soulignent la richesse du rembourrage.

Während die Knöpfe eher traditionell wirken, lässt die Bordüre die Kissen frischer und moderner erscheinen. Beim Spiel mit Kontrasten lassen sich Hingucker schaffen, die die üppige Polsterung betonen.

RELAX COLLECTION

Scotty - B



# Scotty

RELAX SYSTEM

I cuscini della testiera di Scotty si appoggiano al ring, restando dietro al materasso.

Les coussins de la tête de lit de Scotty s'appuient au cadre du lit, en restant derrière le matelas.

The cushions of Scotty's headboard rest on the ring behind the mattress.

Die Kissen des Kopfteils von Scotty ruhen am Bettgestell und bleiben hinter der Matratze.



## Standard version

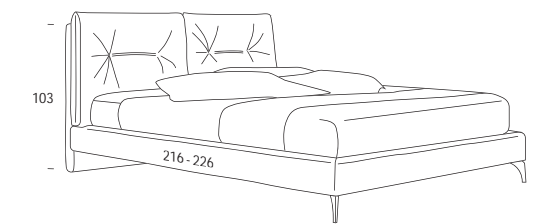
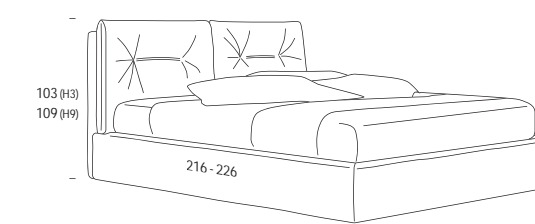
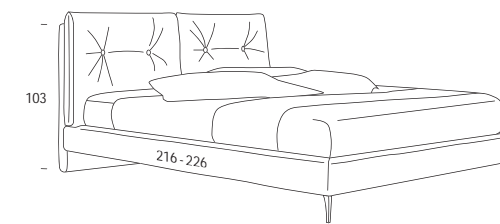

# Scotty Compact

Scotty COMPACT riesce invece a ridurre la profondità totale del letto di 16 cm grazie alla diversa posizione del cuscino della testiera, che si appoggia al materasso stesso.

Scotty COMPACT réussit en revanche à réduire la profondeur totale du lit de 16 cm. Grâce à la position différente du coussin de la tête de lit, qui s'appuie au matelas même.

Scotty COMPACT reduces the overall bed depth by 16 cm due to the different position of the headboard cushion resting on the mattress itself.

Scotty COMPACT hingegen schafft es, die Gesamttiefe des Bettes um 16 cm zu verringern, da das Kissen des Kopfteils anders positioniert ist und auf der Matratze selbst aufliegt.

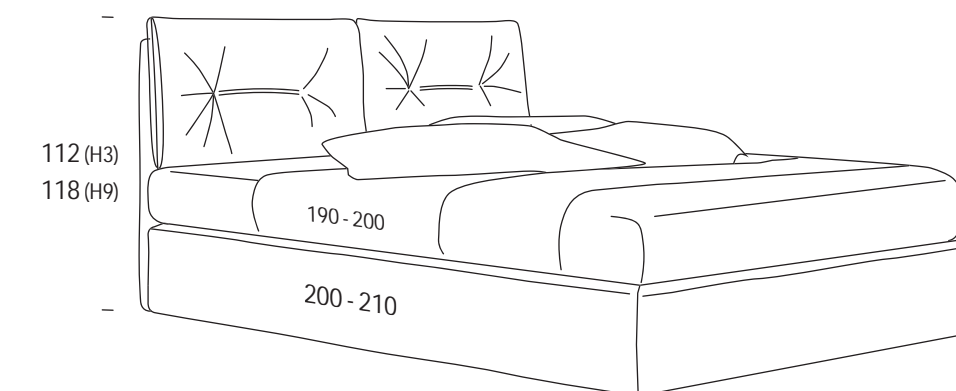

## Compact version

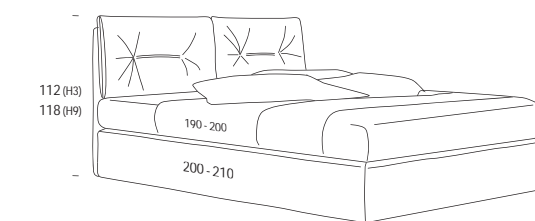
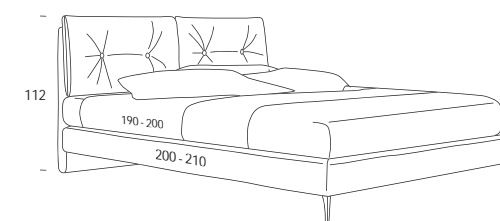

# Scotty RELAX SYSTEM

A - Eko



A - Tokyo



# Scotty Compact

A Compact - Smart



A Compact - York



B - Eko



B - Tokyo



B Compact - Smart



B Compact - York



# Scotty

COMPLETAMENTE SFODERABILE / COMPLETELY REMOVABLE FABRIC / COMPLÈTEMENT DÉHOUSSABLE / VOLLSTÄNDIG ABZIEHBAR

**MASSELLI** in legno di abete e/o scatolati in multistrato di legno di pioppo.

**PANNELLI** da 18/25 mm in particelle di legno di pioppo in classe E1 a bassa emissione di formaldeide e fibra di legno naturale.

**ESPANSI** di poliuretano in densità da 18 kg/mc a 40 kg/mc. Cuscini rivestiti in ovatta da 300 gr.

**PRIMO RIVESTIMENTO** in espanso di poliesteri accoppiato a caldo a vellutino aggrappante in poliesteri e/o ovatta di poliesteri al 100% da 200gr.

**PANNELLI FONDO** contenitore da 12-14 mm in particelle di legno di pioppo in classe E1.

**FORGINGS** fir wood, and/or boxed in poplar plywood.

**PANELS** 18/25 mm in poplar wood particles class E1 low formaldehyde emission and natural wood fiber.

**POLYURETHANE FOAM** density from 18 kg/mc to 40 kg/mc. Cushions coated with 300 gr wadding.

**FIRST COATING** hot bonded polyester foam, velvet adhesion in polyester and/or 100% polyester wool, 200gr.

**CONTAINER BOTTOM** panels 12-14 mm in poplar wood particles class E1.

**TIGE** en pin et/ou boitiers en multicouche en bois de peuplier

**Panneaux** de 18/25 mm en particules de bois de peuplier classe E1 à faible émission de formaldéhyde et fibre de bois naturelle.

**POLYURÉTHANE EXPANSÉ** densité de 18kg/m<sup>3</sup> à 40kg/m<sup>3</sup>. Coussin rembourrés avec de la ouate de 300g.

**PREMIER REVÊTEMENT** en polyester expansé accouplé à chaud à un velours accrochant en polyester et/ou ouate de polyester à 100% de 200g.

**PANNEAUX DE FOND COFFRE** rangement de 12-14mm en particules de bois de peuplier classe E1.

**MASSIVES** Tannenholz und/oder Blöcke aus Pappelmeerschichholz.

**SPANPLATTEN** aus Pappelholz mit 18/25 mm Schichtdicke der Klasse E1, geringer Formaldehydabgabe und natürlichen Holzfasern.

**POLYURETHANSCHAUM** mit Dichten von 18 kg/m<sup>3</sup> bis 40 kg/m<sup>3</sup>. Kissen mit Watte zu 300 g überzogen.

**ERSTER ÜBERZUG** aus Polyesterschaum, der auf Polyester-Samt und/oder 100% Polyesterwatte (zu 200 g) heiß aufkaschiert wurde.

**BODENPLATTEN** des Bettkastens aus 12-14 mm starken Spanplatten aus Pappelholz der Klasse E1.

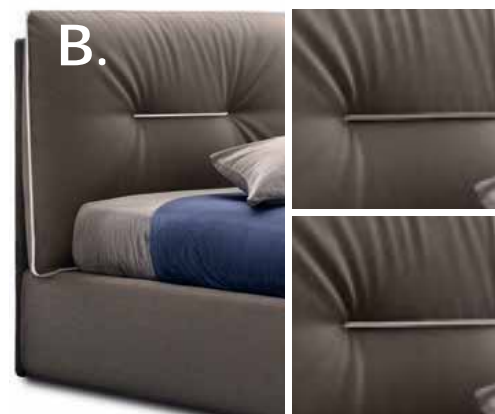
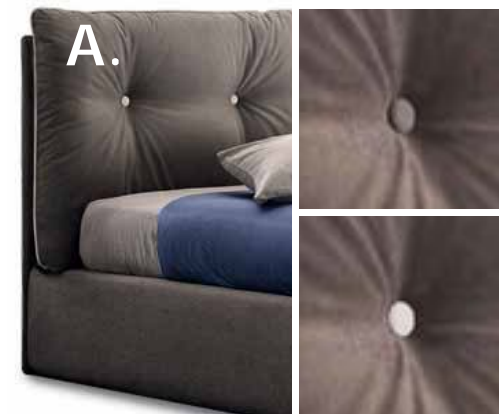

Portagioie Jewelry Box Porte-bijoux Schmuckkästchen p. 542

Porta USB USB holder Port USB USB-Anschluss p. 543

Bottoni o cordoncino in tinta unita come il tessuto o a contrasto. / Buttons or piping plain coloured like the fabric or contrasting. / Boutons ou cordonnet en teinte unie comme le tissu ou en contraste. / Knöpfe oder Bordüre in der gleichen Farbe wie der Stoff oder in einer Kontrastfarbe.

## Optional

Rete / Support / Sommier / Lattenrost Pag 548

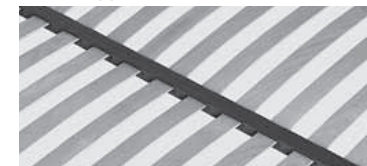

Armony (Standard)

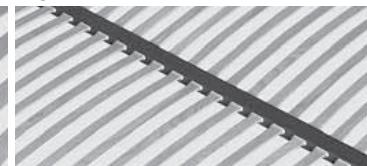

Thai 46 doghe 46 slats 46attes 46 Leisten

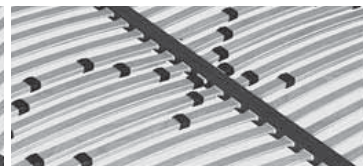

Energy Non applicabile a rete da 120 cm Not applicable to 120 cm support Non applicable au sommier de 120 cm Gilt nicht für Lattenrost zu 120 cm

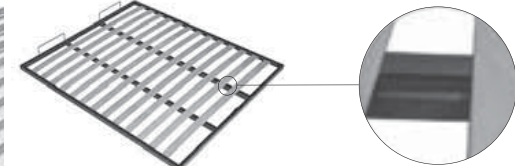

Doppio Flip Solo 140/160x190/200 - 180x200 Only 140/160x190/200 - 180x200 Uniquement 140/160x190/200 - 180x200 Nur 140/160x190/200 - 180x200

Pag 552



Sacco contenitore multiuso Multipurpose storage bag Sac coffre de rangement multi usage Mehrzweck-Aufbewahrungstasche

Pag 553



Tessuto coprirete traspirante antipolvere Support cover fabric breathable and dustproof Tissu couvre-sommier transpirant anti-poussière Atmungsaktives, vor Staub schützendes Gewebe

Pag 557



Regolatore altezza rete solo per reti in appoggio Support height adjuster only for resting frames Réglage hauteur sommier uniquement pour sommiers à poser Lattenrost-Höhenverstellung nur für aufliegende Lattenroste

Pag 556



Clean Up System

## RELAX SYSTEM

### RING EKO

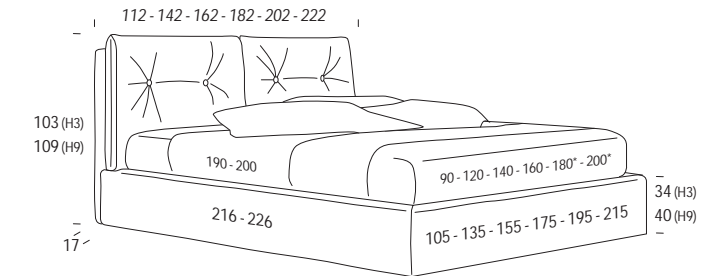

\* Rete L. 180 e L. 200 cm solo profondità 200 cm / Support W. 180 and W. 200 cm only D 200 cm / Sommier L. 180 et L. 200 cm uniquement en profondeur 200 cm / Attenrost B. 180 und B. 200 cm nur mit Tiefe 200 cm

Standard BASIC H 3



Wengé / Wengé / Wengé / Wengé



Argento / Silver / Argent / Silber

Pag 545



Nero / Black / Noir / Schwarz



Bianco / White / Blanc / Weiß

Optional LUX H 3



Wengé / Wengé / Wengé / Wengé



Cromo / Chrome / Chrom / Chrom

Pag 545



Nero / Black / Noir / Schwarz



Bianco / White / Blanc / Weiß

Optional VISUAL H 9



Wengé / Wengé / Wengé / Wengé



Argento / Silver / Argent / Silber

Pag 545



Nero / Black / Noir / Schwarz



Bianco / White / Blanc / Weiß

## Optional Pag 550

Meccanica / Mechanism / Mécanique / Mechanisch

Dynamic



Maverick

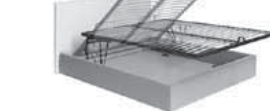

### RING TOKYO

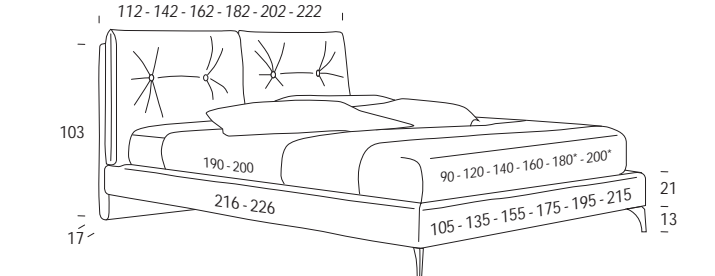

\* Rete L. 180 e L. 200 cm solo profondità 200 cm / Support W. 180 and W. 200 cm only D 200 cm / Sommier L. 180 et L. 200 cm uniquement en profondeur 200 cm / Attenrost B. 180 und B. 200 cm nur mit Tiefe 200 cm

Standard BLADE H 13



Satinato / Satin / Satiné / Satiniert

Pag 546



Bronzato / Bronze / Bronze / Bronziert

Optional TOWER H 13



Optional PLEXY H 13



Pag 546

## Optional Pag 550

Meccanica / Mechanism / Mécanique / Mechanisch

Dynamic



# Scotty Compact

COMPLETAMENTE SFODERABILE / COMPLETELY REMOVABLE FABRIC / COMPLÈTEMENT DÉHOUSSABLE / VOLLSTÄNDIG ABZIEHBAR

**MASSELLI** in legno di abete e/o scatolati in multistrato di legno di pioppo.

**PANNELLI** da 18/25 mm in particelle di legno di pioppo in classe E1 a bassa emissione di formaldeide e fibra di legno naturale.

**ESPANSI** di poliuretano in densità da 18 kg/mc a 40 kg/mc. Cuscini rivestiti in ovatta da 300 gr.

**PRIMO RIVESTIMENTO** in espanso di poliestere accoppiato a caldo a vellutino aggrappante in poliestere e/o ovatta di poliestere al 100% da 200gr.

**PANNELLI FONDO** contenitore da 12-14 mm in particelle di legno di pioppo in classe E1.

**FORGINGS** fir wood, and/or boxed in poplar plywood.

**PANELS** 18/25 mm in poplar wood particles class E1 low formaldehyde emission and natural wood fiber.

**POLYURETHANE FOAM** density from 18 kg/mc to 40 kg/mc. Cushions coated with 300 gr wadding.

**FIRST COATING** hot bonded polyester foam, velvet adhesion in polyester and/or 100% polyester wool, 200gr.

**CONTAINER BOTTOM** panels 12-14 mm in poplar wood particles class E1.

**TIGE** en pin et/ou boitiers en multicouche en bois de peuplier

**Panneaux** de 18/25 mm en particules de bois de peuplier classe E1 à faible émission de formaldéhyde et fibre de bois naturelle.

**POLYURÉTHANE EXPANSÉ** densité de 18kg/m<sup>3</sup> à 40kg/m<sup>3</sup>. Coussin rembourrés avec de la ouate de 300g.

**PREMIER REVÊTEMENT** en polyester expansé accouplé à chaud à un velours accrochant en polyester et/ou ouate de polyester à 100% de 200g.

**PANNEAUX DE FOND COFFRE** rangement de 12-14mm en particules de bois de peuplier classe E1.

**MASSIVES** Tannenholz und/oder Blöcke aus Pappelholzschichtholz.

**SPANPLATTEN** aus Pappelholz mit 18/25 mm Schichtdicke der Klasse E1, geringer Formaldehydabgabe und natürlichen Holzfasern.

**POLYURETHANSCHAUM** mit Dichten von 18 kg/m<sup>3</sup> bis 40 kg/m<sup>3</sup>. Kissen mit Watte zu 300 g überzogen.

**ERSTER ÜBERZUG** aus Polyesterschaum, der auf Polyester-Samt und/oder 100% Polyesterwatte (zu 200 g) heiß aufkaschiert wurde.

**BODENPLATTEN** des Bettkastens aus 12-14 mm starken Spanplatten aus Pappelholz der Klasse E1.

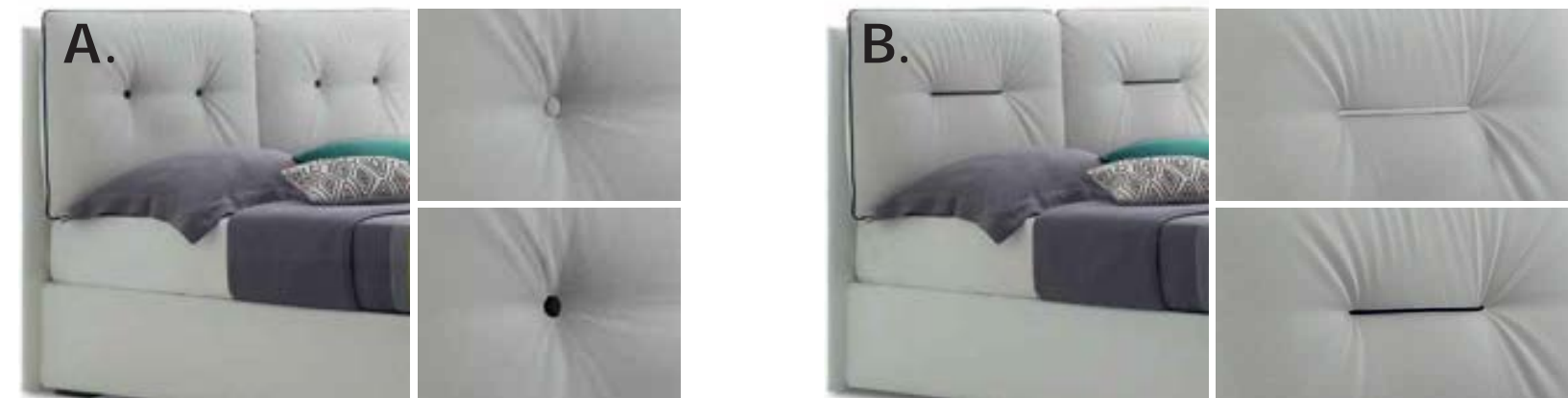

Bottoni o cordoncino in tinta unita come il tessuto o a contrasto. / Buttons or piping plain coloured like the fabric or contrasting. / Boutons ou cordonnet en teinte unie comme le tissu ou en contraste. / Knöpfe oder Bordüre in der gleichen Farbe wie der Stoff oder in einer Kontrastfarbe.

## Optional

Rete / Support / Sommier / Lattenrost Pag 548

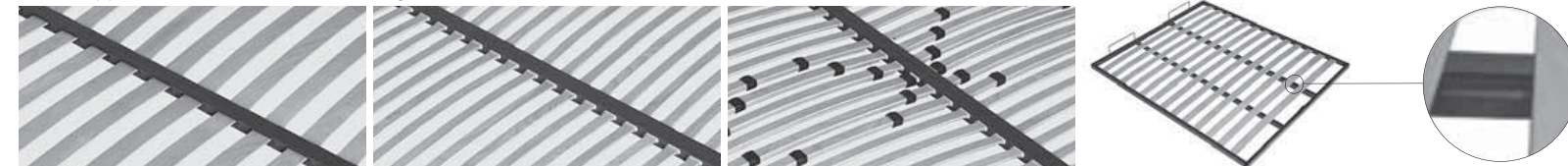

**Armony** (Standard)

**Thai**  
46 doghe  
46 slats  
46 attes  
46 Leisten

**Energy**  
Non applicabile a rete da 120 cm  
Not applicable to 120 cm support  
Non applicable au sommier de 120 cm  
Gilt nicht für Lattenrost zu 120 cm

**Doppio Flip**  
Solo 140/160x190/200 - 180x200  
Only 140/160x190/200 - 180x200  
Uniquement 140/160x190/200 - 180x200  
Nur 140/160x190/200 - 180x200

Pag 552



**Sacco contenitore multiuso**  
Multipurpose storage bag  
Sac coffre de rangement multi usage  
Mehrzweck-Aufbewahrungstasche

Pag 553



**Tessuto coprirete traspirante antipolvere**  
Support cover fabric breathable and dustproof  
Tissu couvre-sommier respirant anti-poussière  
Atmungsaktives, vor Staub schützendes Gewebe

Pag 557



**Regolatore altezza rete solo per reti in appoggio**  
Support height adjuster only for resting frames  
Réglage hauteur sommier uniquement pour sommiers à poser  
Lattenrost-Höhenverstellung nur für aufliegende Lattenroste

Pag 556



**Clean Up System**

## RELAX SYSTEM

### RING SMART

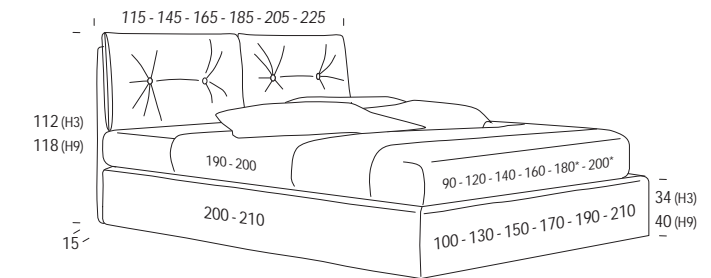

\* Rete L. 180 e L. 200 cm solo profondità 200 cm / Support W. 180 and W. 200 cm only D 200 cm / Sommier L. 180 et L. 200 cm uniquement en profondeur 200 cm / Attenrost B. 180 und B. 200 cm nur mit Tiefe 200 cm

Standard **BASIC H 3**

Pag 545



Wengé / Wengé  
/ Wengé / Wengé



Nero / Black  
/ Noir / Schwarz

Optional **LUX H 3**

Pag 545



Wengé / Wengé  
/ Wengé / Wengé



Nero / Black  
/ Noir / Schwarz

Optional **VISUAL H 9**

Pag 545



Wengé / Wengé  
/ Wengé / Wengé



Nero / Black  
/ Noir / Schwarz



Argento / Silver  
/ Argent / Silber



Bianco / White  
/ Blanc / Weiß



Cromo / Chrome  
/ Chrome / Chrom



Bianco / White  
/ Blanc / Weiß



Argento / Silver  
/ Argent / Silber



Bianco / White  
/ Blanc / Weiß

## Optional Pag 550

Meccanica / Mechanism  
/ Mécanique / Mechanisch

Dynamic



Maverick



### RING YORK

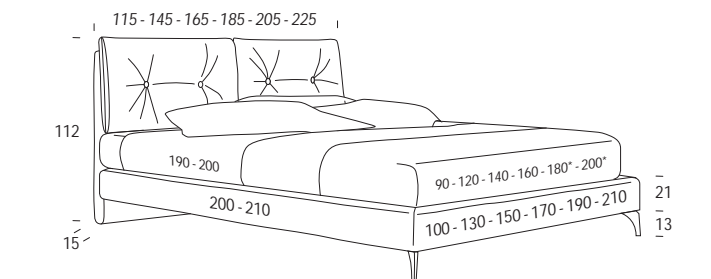

\* Rete L. 180 e L. 200 cm solo profondità 200 cm / Support W. 180 and W. 200 cm only D 200 cm / Sommier L. 180 et L. 200 cm uniquement en profondeur 200 cm / Attenrost B. 180 und B. 200 cm nur mit Tiefe 200 cm

Standard **BLADE H 13**

Pag 546



Satinato / Satin  
/ Satiné / Satiniert



Bronzato / Bronze  
/ Bronze / Bronziert

Optional **TOWER H 13**

Optional **PLEXY H 13**

Pag 546



## Optional Pag 550

Meccanica / Mechanism  
/ Mécanique / Mechanisch

Dynamic



# Henry



Con il suo disegno fine e grazioso, Henry diventerà il protagonista in ogni camera da letto. Elegante e un po' chic, la testiera composta dagli ampi cuscini è perfetta per abbandonarsi al totale relax.

Henry will be the focal point in every bedroom with its thin and nice design. Stylish and a little chic, the headboard consisting of large cushions is suitable for indulging in complete relaxation.

De par son dessin fin et gracieux, Henry deviendra le protagoniste de chaque chambre à coucher. Élégant et un peu chic, la tête de lit composée par plusieurs coussins est parfaite pour s'y abandonner en total relax.

Mit seinem feinen und anmutigen Design wird Henry der Star in jedem Schlafzimmer. Das elegante und chic wirkende Kopfteil aus großen Kissen ist perfekt, um sich zu entspannen.









Un bordo semplice, effetto pizzicato sottolinea la pulizia del disegno nei grandi cuscini e sugli angoli esterni del giroletto. Alla base della testiera, sul piano letto il comodo portaoggetti.

A simple edge with a pinched effect emphasizes the clean design of the large pillows and the outer corners of the bed frame. At the base of the headboard at the level of the bed lies the convenient storage bag.

Un bord simple, effet pincé, souligne la netteté du dessin des grands coussins et sur les angles externes du tout de lit. À la base de la tête de lit, sur le bord du lit un pratique porte-objets.

Eine schlichte Kante in Pinched-Optik betont die klare Linienführung des Designs an den großen Kissen und den äußeren Ecken des Bettrahmens. Am Fuß des Kopfteils, auf Betthöhe, die praktische Ablegemöglichkeit.

# Henry

COMPLETAMENTE SFODERABILE / COMPLETELY REMOVABLE FABRIC / COMPLÈTEMENT DÉHOUSSABLE / VOLLSTÄNDIG ABZIEHBAR

**MASSELLI** in legno di abete e/o scatolati in multistrato di legno di pioppo.

**PANNELLI** da 18/25 mm in particelle di legno di pioppo in classe E1 a bassa emissione di formaldeide e fibra di legno naturale.

**ESPANSI** di poliuretano in densità da 18 kg/mc a 40 kg/mc. Cuscini rivestiti in ovatta da 300 gr.

**PRIMO RIVESTIMENTO** in espanso di poliestere accoppiato a caldo a vellutino aggrappante in poliestere e/o ovatta di poliestere al 100% da 200gr.

**PANNELLI FONDO** contenitore da 12-14 mm in particelle di legno di pioppo in classe E1.

**FORGINGS** fir wood, and/or boxed in poplar plywood.

**PANELS** 18/25 mm in poplar wood particles class E1 low formaldehyde emission and natural wood fiber.

**POLYURETHANE FOAM** density from 18 kg/mc to 40 kg/mc. Cushions coated with 300 gr wadding.

**FIRST COATING** hot bonded polyester foam, velvet adhesion in polyester and/or 100% polyester wool, 200gr.

**CONTAINER BOTTOM** panels 12-14 mm in poplar wood particles class E1.

**TIGE** en pin et/ou boitiers en multicouche en bois de peuplier.

**PANNEAUX** de 18/25 mm en particules de bois de peuplier classe E1 à faible émission de formaldéhyde et fibre de bois naturelle.

**POLYURÉTHANE EXPANSÉ** densité de 18kg/m<sup>3</sup> à 40kg/m<sup>3</sup>. Coussin rembourrés avec de la ouate de 300g.

**PREMIER REVÊTEMENT** en polyester expansé accouplé à chaud à un velours accrochant en polyester et/ou ouate de polyester à 100% de 200g.

**PANNEAUX DE FOND COFFRE** rangement de 12-14mm en particules de bois de peuplier classe E1.

**MASSIVES** Tannenholz und/oder Blöcke aus Pappelmehrschichtholz.

**SPANPLATTEN** aus Pappelholz mit 18/25 mm Schichtdicke der Klasse E1, geringer Formaldehydabgabe und natürlichen Holzfasern.

**POLYURETHANSCHAUM** mit Dichten von 18 kg/m<sup>3</sup> bis 40 kg/m<sup>3</sup>. Kissen mit Watte zu 300 g überzogen.

**ERSTER ÜBERZUG** aus Polyesterschaum, der auf Polyester-Samt und/oder 100% Polyesterwatte (zu 200 g) heiß aufkaschiert wurde.

**BODENPLATTEN** des Bettkastens aus 12-14 mm starken Spanplatten aus Pappelholz der Klasse E1.



Portagioie  
Jewelry Box  
Parte-bijoux  
Schmuckkästchen  
p. 542



Porta USB  
USB holder  
Port USB  
USB-Anschluss  
p. 543

## Optional

Rete / Support / Sommier / Lattenrost Pag 548

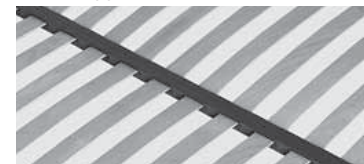

**Armony**  
(Standard)

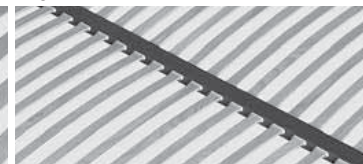

**Thai**  
46 doghe  
46 slats  
46attes  
46 Leisten

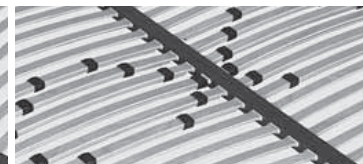

**Energy**  
Non applicabile a rete da 120 cm  
Not applicable to 120 cm support  
Non applicable au sommier de 120 cm  
Gilt nicht für Lattenrost zu 120 cm

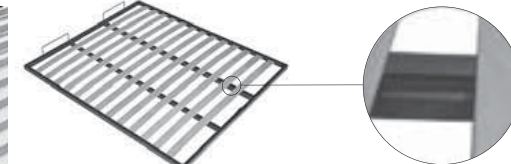

**Doppio Flip**  
Solo 140/160x190/200 - 180x200  
Only 140/160x190/200 - 180x200  
Uniquement 140/160x190/200 - 180x200  
Nur 140/160x190/200 - 180x200

Pag 552



**Sacco contenitore multiuso**  
Multipurpose storage bag  
Sac coffre de rangement multi usage  
Mehrzweck-Aufbewahrungstasche

Pag 553



**Tessuto coprirete traspirante antipolvere**  
Support cover fabric breathable and dustproof  
Tissu couvre-sommier respirant anti-poussière  
Atmungsaktives, vor Staub schützendes Gewebe

Pag 557



**Regolatore altezza rete solo per reti in appoggio**  
Support height adjuster only for resting frames  
Réglage hauteur sommier uniquement pour sommiers à poser  
Lattenrost-Höhenverstellung nur für aufliegende Lattenroste

Pag 556



**Clean Up System**

## RELAX SYSTEM

### RING EKO



### RING LIBERTY



**Gonna in tinta**  
Skirt in matching colour  
Jupe en teinte  
Ton-in-Ton ausgeführter Volant



**Gonna a contrasto**  
Skirt contrasting  
Jupe en contraste  
Farblich abgesetzter Volant

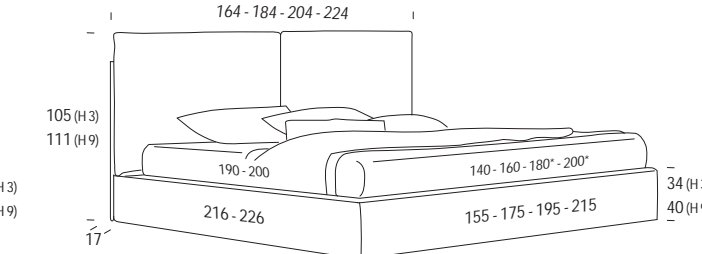
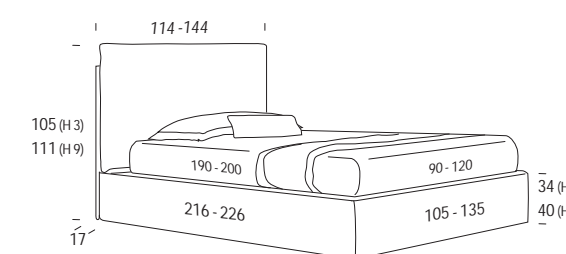

\* Rete L. 180 e L. 200 cm solo profondità 200 cm / Support W. 180 and W. 200 cm only D 200 cm  
/ Sommier L. 180 et L. 200 cm uniquement en profondeur 200 cm / Attenrost B. 180 und B. 200 cm nur mit Tiefe 200 cm

## Optional Pag 550

**Meccanica / Mechanism**  
/ Mécanique / Mechanisch

**Dynamic**



**Maverick**



Standard **BASIC H 3**

Pag 545

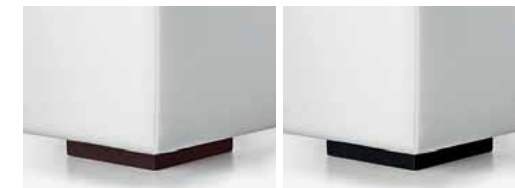

**Wengé / Wengé**  
/ Wengé / Wengé

**Nero / Black**  
/ Noir / Schwarz

Optional **LUX H 3**

Pag 545



**Wengé / Wengé**  
/ Wengé / Wengé

**Nero / Black**  
/ Noir / Schwarz

Optional **VISUAL H 9**

Pag 545



**Wengé / Wengé**  
/ Wengé / Wengé

**Nero / Black**  
/ Noir / Schwarz

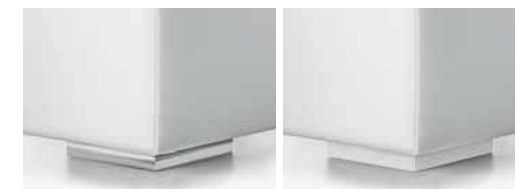

**Argento / Silver**  
/ Argent / Silber

**Bianco / White**  
/ Blanc / Weiß



**Cromo / Chrome**  
/ Chrome / Chrom

**Bianco / White**  
/ Blanc / Weiß



**Argento / Silver**  
/ Argent / Silber

**Bianco / White**  
/ Blanc / Weiß

# Allen



I grandi cuscini di Allen sono valorizzati da un tessuto trapuntato, una citazione classica in un contesto moderno. Sono mobili e consentono la posizione Relax, un comodo appoggio per potersi rilassare davanti ad un buon libro.

Allen's big cushions are enhanced with a quilted fabric, a classic reference set in a modern context. They can be moved around and placed in the Relax position, which provides comfy support for relaxing in front of a good book.

Les grands coussins d'Allen sont mis en valeur par un tissu capitonné, un rappel classique dans un cadre moderne. Ils sont amovibles et peuvent être placés en position Relax, un confortable appui pour se relaxer devant un bon livre.

Die großen Kissen von Allen werden durch gesteppten Stoff aufgewertet, eine klassische Komponente in einem modernen Kontext. Sie sind beweglich und ermöglichen die Relax-Position, eine bequeme Abstützung zum Entspannen bei einem guten Buch.





1.



I grandi morbidi cuscini sono arricchiti dalla trapuntatura a rombi, una citazione classica per un letto moderno. Sono mobili, indipendenti (1) e possono essere appoggiati al materasso in posizione relax (2) "seduta": da lettura... da tv... da tablet...

The big fluffy pillows are enriched by the lozenge quilting, a classic reference for a modern bed. They are mobile, independent (1) and can be placed against the mattress in the "sitting" position (2) for your relax: for reading... watching tv... using your tablet...

2.



Les grands coussins moelleux sont enrichis d'un capitonnage à losanges, un rappel classique pour un lit moderne. Ils sont indépendants (1) et peuvent être placés sur le matelas en position relax (2) "assise": de lecture... de télé... de tablette...

Die großen, weichen Kissen werden durch einen rautenförmig gesteppten Stoff aufgewertet, ein klassisches Element für ein modernes Bett. Sie sind mobil, separat (1) und können auf der Matratze in der Relax-Position (2) zum „Sitzen“ platziert werden: zum Lesen... zum Fernsehen... fürs Tablet...





# Allen

COMPLETAMENTE SFODERABILE / COMPLETELY REMOVABLE FABRIC / COMPLÈTEMENT DÉHOUSSABLE / VOLLSTÄNDIG ABZIEHBAR

**MASSELLI** in legno di abete e/o scatolati in multistrato di legno di pioppo.

**PANNELLI** da 18/25 mm in particelle di legno di pioppo in classe E1 a bassa emissione di formaldeide e fibra di legno naturale.

**ESPANSI** di poliuretano in densità da 18 kg/mc a 40 kg/mc.

**PRIMO RIVESTIMENTO** in espanso di poliestere accoppiato a caldo a vellutino aggrappante in poliestere e/o ovatta di poliestere al 100% da 200gr.

**PANNELLI FONDO** contenitore da 12-14 mm in particelle di legno di pioppo in classe E1.

**FORGINGS** fir wood, and/or boxed in poplar plywood.

**PANELS** 18/25 mm in poplar wood particles class E1 low formaldehyde emission and natural wood fiber.

**POLYURETHANE FOAM** density from 18 kg/mc to 40 kg/mc.

**FIRST COATING** hot bonded polyester foam, velvet adhesion in polyester and/or 100% polyester wool, 200gr.

**CONTAINER BOTTOM** panels 12-14 mm in poplar wood particles class E1.

**TIGE** en pin et/ou boitiers en multicouche en bois de peuplier.

**PANNEAUX** de 18/25 mm en particules de bois de peuplier classe E1 à faible émission de formaldéhyde et fibre de bois naturelle.

**POLYURÉTHANE EXPANSÉ** densité de 18kg/m<sup>3</sup> à 40kg/m<sup>3</sup>.

**PREMIER REVÊTEMENT** en polyester expansé accouplé à chaud à un velours accrochant en polyester et/ou ouate de polyester à 100% de 200g.

**PANNEAUX DE FOND COFFRE** rangement de 12-14mm en particules de bois de peuplier classe E1.

**MASSIVES** Tannenholz und/oder Blöcke aus Pappelmehrschichtholz.

**SPANPLATTEN** aus Pappelholz mit 18/25 mm Schichtdicke der Klasse E1, geringer Formaldehydabgabe und natürlichen Holzfasern.

**POLYURETHANSCHAUM** mit Dichten von 18 kg/m<sup>3</sup> bis 40 kg/m<sup>3</sup>. Kissen mit Watte zu 300 g überzogen.

**ERSTER ÜBERZUG** aus Polyesterschaum, der auf Polyester-Samt und/oder 100% Polyesterwatte (zu 200 g) heiß aufkaschiert wurde.

**BODENPLATTEN** des Bettkastens aus 12-14 mm starken Spanplatten aus Pappelholz der Klasse E1.



**Portagioie**  
Jewelry Box  
Porte-bijoux  
Schmuckkästchen  
p. 542



**Porta USB**  
USB holder  
Port USB  
USB-Anschluss  
p. 543

## Optional

Rete / Support / Sommier / Lattenrost Pag 548

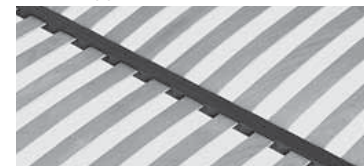

**Armony**  
(Standard)

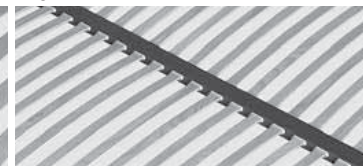

**Thai**  
46 doghe  
46 slats  
46 attes  
46 Leisten

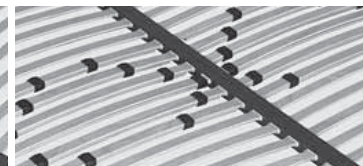

**Energy**  
Non applicabile a rete da 120 cm  
Not applicable to 120 cm support  
Non applicable au sommier de 120 cm  
Gilt nicht für Lattenrost zu 120 cm

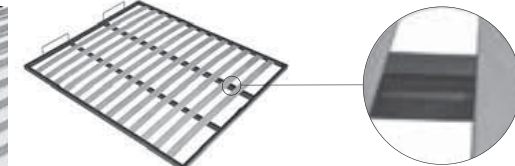

**Doppio Flip**  
Solo 140/160x190/200 - 180x200  
Only 140/160x190/200 - 180x200  
Uniquement 140/160x190/200 - 180x200  
Nur 140/160x190/200 - 180x200

Pag 552



**Sacco contenitore multiuso**  
Multipurpose storage bag  
Sac coffre de rangement multi usage  
Mehrzweck-Aufbewahrungstasche

Pag 553



**Tessuto coprirete traspirante antipolvere**  
Support cover fabric breathable and dustproof  
Tissu couvre-sommier respirant anti-poussière  
Atmungsaktives, vor Staub schützendes Gewebe

Pag 557



**Regolatore altezza rete solo per reti in appoggio**  
Support height adjuster only for resting frames  
Réglage hauteur sommier uniquement pour sommiers à poser  
Lattenrost-Höhenverstellung nur für aufliegende Lattenroste

Pag 556



**Clean Up System**

## RELAX SYSTEM

### RING EKO



### RING LIBERTY



**Gonna in tinta**  
Skirt in matching colour  
Jupe en teinte  
Ton-in-Ton ausgeführter Volant



**Gonna a contrasto**  
Skirt contrasting  
Jupe en contraste  
Farblich abgesetzter Volant

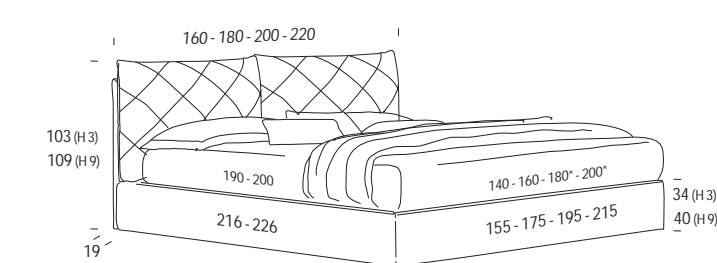
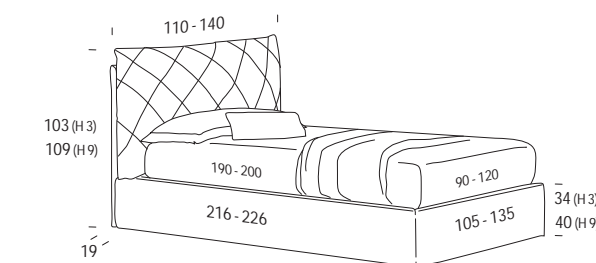

\* Rete L. 180 e L. 200 cm solo profondità 200 cm / Support W. 180 and W. 200 cm only D 200 cm  
/ Sommier L. 180 et L. 200 cm uniquement en profondeur 200 cm / Attenrost B. 180 und B. 200 cm nur mit Tiefe 200 cm

## Optional Pag 550

**Meccanica / Mechanism**  
/ Mécanique / Mechanisch

**Dynamic**



**Maverick**

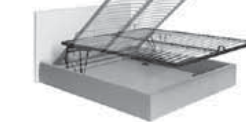

Standard **BASIC H 3**

Pag 545



**Wengé / Wengé**  
/ Wengé / Wengé



**Nero / Black**  
/ Noir / Schwarz

Optional **LUX H 3**

Pag 545



**Wengé / Wengé**  
/ Wengé / Wengé



**Nero / Black**  
/ Noir / Schwarz

Optional **VISUAL H 9**

Pag 545



**Wengé / Wengé**  
/ Wengé / Wengé



**Nero / Black**  
/ Noir / Schwarz



**Argento / Silver**  
/ Argent / Silber



**Bianco / White**  
/ Blanc / Weiß



**Cromo / Chrome**  
/ Chrome / Chrom



**Bianco / White**  
/ Blanc / Weiß



**Argento / Silver**  
/ Argent / Silber



**Bianco / White**  
/ Blanc / Weiß



# Edgar



I grandi cuscini di Edgar si contraddistinguono per il movimento creato dalla doppia cucitura a rilievo, particolare sartoriale che evidenzia il morbido spessore della superficie.

Edgar's large headboard cushions feature an intriguing design created by the relief double top stitching, a tailoring detail designed to emphasise the soft thickness of the surface.

Les grands coussins d'Edgar se caractérisent par le mouvement créé par une double couture en relief, un détail haute couture qui met en évidence l'épaisseur moelleuse du revêtement.

Die großen Kissen von Edgar zeichnen sich durch Bewegung aus, die durch die doppelte, hervorstehende Naht entsteht, ein besonderes handwerkliches Detail, das die weiche Struktur der Oberfläche betont.







Il rivestimento avvolge i grandi cuscini e li impreziosisce con un nuovo inconsueto disegno che, libero, naturale e senza bottoni, muove la superficie ed evidenzia il morbido spessore.

The cover surrounds the large pillows and marks them with a new unusual design that, free, natural, and without buttons, moves the surface and highlights the soft thickness.

Le revêtement enveloppe les grands coussins, il les marque avec un nouveau dessin qui est libre, naturel et sans boutons, il ravive et il met en évidence l'épaisseur moelleuse.

Der Bezug umhüllt die großen Kissen und verfeinert sie mit einem neuen und ungewöhnlichen Design, das ungezwungen, natürlich und ganz ohne Knöpfe Bewegung in die Oberfläche bringt und die weiche Struktur hervorhebt.



**Relax System**  
 Grazie all'innovativa soluzione dei cuscini reclinabili molte testiere sono relax system, consentono cioè una comoda posizione "seduta" e un pratico appoggio di sostegno per leggere, guardare la tv, lavorare al laptop...

**Relax System**  
 With the innovative solution of the headboard cushions, many headboards become relaxation systems, that is, allow a comfortable position while "sitting" and a practical support for reading, watching TV, working on laptop...

**Relax System**  
 Grâce à la solution innovante des coussins tête de lit inclinable, de nombreuses tête de lits sont « relax system », elles permettent d'avoir une position assise commode et un appui pratique pour lire, regarder la télé, travailler avec l'ordinateur portable...

**Relax System**  
 Dank der innovativen Lösung mit neigbaren Kissen werden viele Kopfteile zu einem Relax-System, bieten eine bequeme „Sitzposition“ und stützen den Rücken beim Lesen, Fernsehen, Arbeiten am Laptop...



# Edgar

COMPLETAMENTE SFODERABILE / COMPLETELY REMOVABLE FABRIC / COMPLÈTEMENT DÉHOUSSABLE / VOLLSTÄNDIG ABZIEHBAR

**MASSELLI** in legno di abete e/o scatolati in multistrato di legno di pioppo.

**PANNELLI** da 18/25 mm in particelle di legno di pioppo in classe E1 a bassa emissione di formaldeide e fibra di legno naturale.

**ESPANSI** di poliuretano in densità da 18 kg/mc a 40 kg/mc. Cuscini rivestiti in ovatta da 300 gr.

**PRIMO RIVESTIMENTO** in espanso di poliestere accoppiato a caldo a vellutino aggrappante in poliestere e/o ovatta di poliestere al 100% da 200gr.

**PANNELLI FONDO** contenitore da 12-14 mm in particelle di legno di pioppo in classe E1.

**FORGINGS** fir wood, and/or boxed in poplar plywood.

**PANELS** 18/25 mm in poplar wood particles class E1 low formaldehyde emission and natural wood fiber.

**POLYURETHANE FOAM** density from 18 kg/mc to 40 kg/mc. Cushions coated with 300 gr wadding.

**FIRST COATING** hot bonded polyester foam, velvet adhesion in polyester and/or 100% polyester wool, 200gr.

**CONTAINER BOTTOM** panels 12-14 mm in poplar wood particles class E1.

**TIGE** en pin et/ou boitiers en multicouche en bois de peuplier.

**PANNEAUX** de 18/25 mm en particules de bois de peuplier classe E1 à faible émission de formaldéhyde et fibre de bois naturelle.

**POLYURÉTHANE EXPANSÉ** densité de 18kg/m<sup>3</sup> à 40kg/m<sup>3</sup>. Coussin rembourrés avec de la ouate de 300g.

**PREMIER REVÊTEMENT** en polyester expansé accouplé à chaud à un velours accrochant en polyester et/ou ouate de polyester à 100% de 200g.

**PANNEAUX DE FOND COFFRE** rangement de 12-14mm en particules de bois de peuplier classe E1.

**MASSIVES** Tannenholz und/oder Blöcke aus Pappelmeerschichholz.

**SPANPLATTEN** aus Pappelholz mit 18/25 mm Schichtdicke der Klasse E1, geringer Formaldehydabgabe und natürlichen Holzfasern.

**POLYURETHANSCHAUM** mit Dichten von 18 kg/m<sup>3</sup> bis 40 kg/m<sup>3</sup>. Kissen mit Watte zu 300 g überzogen.

**ERSTER ÜBERZUG** aus Polyesterschaum, der auf Polyester-Samt und/oder 100% Polyesterwatte (zu 200 g) heiß aufkaschiert wurde.

**BODENPLATTEN** des Bettkastens aus 12-14 mm starken Spanplatten aus Pappelholz der Klasse E1.



**Portagioie**  
Jewelry Box  
Parte-bijoux  
Schmuckkästchen  
p. 542



**Porta USB**  
USB holder  
Port USB  
USB-Anschluss  
p. 543

## Optional

**Rete / Support / Sommier / Lattenrost** Pag 548

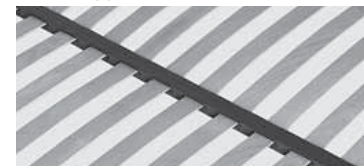

**Armony**  
(Standard)

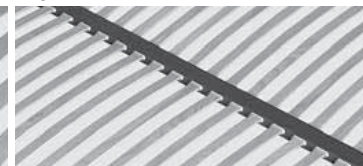

**Thai**  
46 doghe  
46 slats  
46attes  
46 Leisten

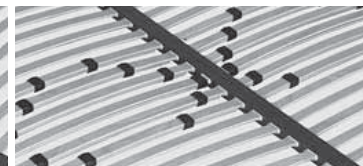

**Energy**  
Non applicabile a rete da 120 cm  
Not applicable to 120 cm support  
Non applicable au sommier de 120 cm  
Gilt nicht für Lattenrost zu 120 cm

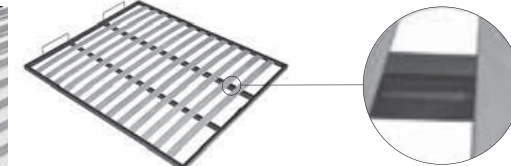

**Doppio Flip**  
Solo 140/160x190/200 - 180x200  
Only 140/160x190/200 - 180x200  
Uniquement 140/160x190/200 - 180x200  
Nur 140/160x190/200 - 180x200

Pag 552



**Sacco contenitore multiuso**  
Multipurpose storage bag  
Sac coffre de rangement multi usage  
Mehrzweck-Aufbewahrungstasche

Pag 553



**Tessuto coprirete traspirante antipolvere**  
Support cover fabric breathable and dustproof  
Tissu couvre-sommier transpirant anti-poussière  
Atmungsaktives, vor Staub schützendes Gewebe

Pag 557



**Regolatore altezza rete solo per reti in appoggio**  
Support height adjuster only for resting frames  
Règlage hauteur sommier uniquement pour sommiers à poser  
Lattenrost-Höhenverstellung nur für aufliegende Lattenroste

Pag 556



**Clean Up System**

## RELAX SYSTEM

### RING EKO

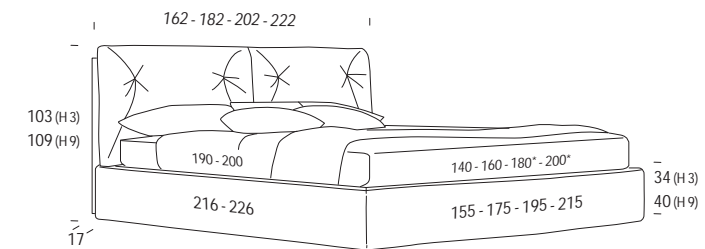
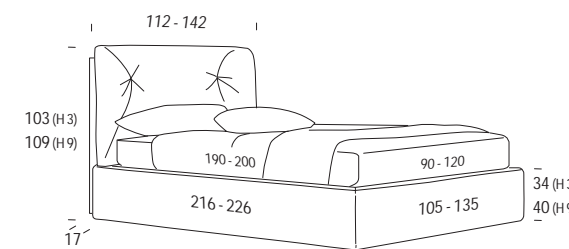

### Optional Pag 550

**Meccanica / Mechanism**  
/ Mécanique / Mechanisch

**Dynamic**



**Maverick**



\* Rete L. 180 e L. 200 cm solo profondità 200 cm / Support W. 180 and W. 200 cm only D 200 cm  
/ Sommier L. 180 et L. 200 cm uniquement en profondeur 200 cm / Attenrost B. 180 und B. 200 cm nur mit Tiefe 200 cm

**Standard BASIC H 3** Pag 545



**Wengé / Wengé**  
/ Wengé / Wengé



**Nero / Black**  
/ Noir / Schwarz

**Optional LUX H 3** Pag 545



**Wengé / Wengé**  
/ Wengé / Wengé



**Nero / Black**  
/ Noir / Schwarz

**Optional VISUAL H 9** Pag 545



**Wengé / Wengé**  
/ Wengé / Wengé



**Nero / Black**  
/ Noir / Schwarz



**Argento / Silver**  
/ Argent / Silber



**Bianco / White**  
/ Blanc / Weiß



**Cromo / Chrome**  
/ Chrome / Chrom



**Bianco / White**  
/ Blanc / Weiß



**Argento / Silver**  
/ Argent / Silber



**Bianco / White**  
/ Blanc / Weiß

# George



La cucitura con impatto estetico preciso e forte delinea i bordi dei cuscini e della struttura del letto, ricreando un dettaglio stilistico e sartoriale giovane e contemporaneo.

The stitching with its strong, exacting aesthetic impact defines the outlines of the cushions and bed frame, recreating young, contemporary, tailored style and detail.

La couture a un impact esthétique précis et fort. Elle dessine les bords des coussins et de la structure du lit et recrée un détail stylé et haute couture jeune et contemporain.

Die Naht mit ihrer beeindruckenden ästhetischen Wirkung grenzt die Ränder der Kissen und der Bettstruktur ab und schafft so ein jugendlich-zeitgemäßes stilistisches und handwerkliches Detail.

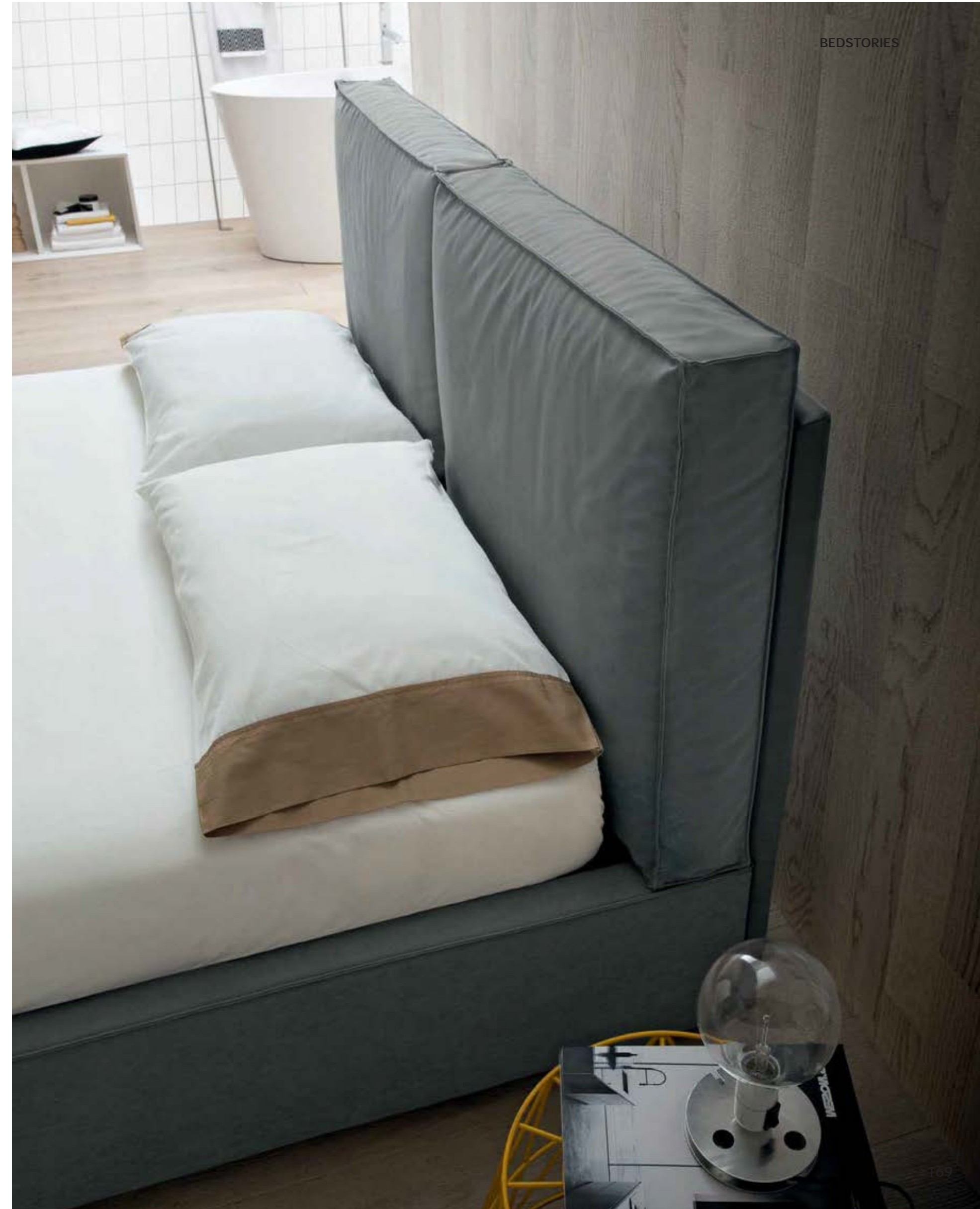



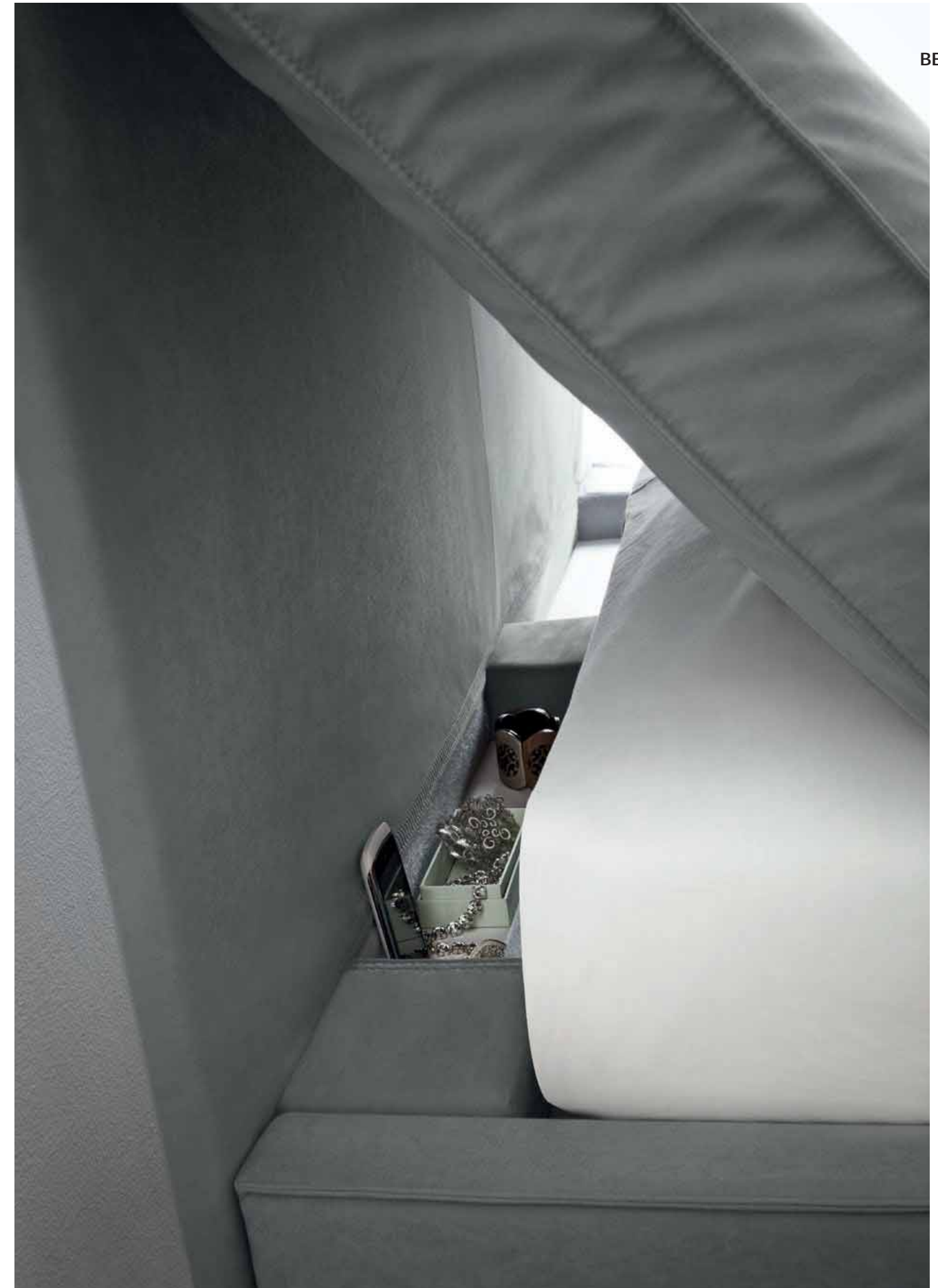

Relax System  
Grazie all'innovativa  
soluzione dei cuscini  
reclinabili le testiere sono  
relax system, consentono  
cioè una comoda posizione  
"seduta" e un pratico  
appoggio di sostegno per  
leggere, guardare la tv,  
lavorare al laptop...

Relax System  
With the innovative solution  
of the headboard cushions,  
many headboards become  
relaxation systems, that  
is, allow a comfortable  
position while "sitting"  
and a practical support  
for reading, watching TV,  
working on laptop...

Relax System  
Grâce à la solution  
innovante des coussins  
tête de lit inclinable, de  
nombreuses tête de lits  
sont « relax system », elles  
permettent d'avoir une  
position assise commode  
et un appui pratique  
pour lire, regarder la télé,  
travailler avec l'ordinateur  
portable...

Dank der innovativen  
Lösung mit neigbaren  
Kissen werden viele  
Kopfteile zu einem Relax-  
System, bieten eine  
bequeme „Sitzposition“ und  
stützen den Rücken beim  
Lesen, Fernsehen, Arbeiten  
am Laptop...





# George

COMPLETAMENTE SFODERABILE / COMPLETELY REMOVABLE FABRIC / COMPLÈTEMENT DÉHOUSSABLE / VOLLSTÄNDIG ABZIEHBAR

**MASSELLI** in legno di abete e/o scatolati in multistrato di legno di pioppo.

**PANNELLI** da 18/25 mm in particelle di legno di pioppo in classe E1 a bassa emissione di formaldeide e fibra di legno naturale.

**ESPANSI** di poliuretano in densità da 18 kg/mc a 40 kg/mc. Cuscini rivestiti in ovatta da 300 gr.

**PRIMO RIVESTIMENTO** in espanso di poliestere accoppiato a caldo a vellutino aggrappante in poliestere e/o ovatta di poliestere al 100% da 200gr.

**PANNELLI FONDO** contenitore da 12-14 mm in particelle di legno di pioppo in classe E1.

**FORGINGS** fir wood, and/or boxed in poplar plywood.

**PANELS** 18/25 mm in poplar wood particles class E1 low formaldehyde emission and natural wood fiber.

**POLYURETHANE FOAM** density from 18 kg/mc to 40 kg/mc. Cushions coated with 300 gr wadding.

**FIRST COATING** hot bonded polyester foam, velvet adhesion in polyester and/or 100% polyester wool, 200gr.

**CONTAINER BOTTOM** panels 12-14 mm in poplar wood particles class E1.

**TIGE** en pin et/ou boitiers en multicouche en bois de peuplier.

**PANNEAUX** de 18/25 mm en particules de bois de peuplier classe E1 à faible émission de formaldéhyde et fibre de bois naturelle.

**POLYURÉTHANE EXPANSÉ** densité de 18kg/m<sup>3</sup> à 40kg/m<sup>3</sup>. Coussin rembourrés avec de la ouate de 300g.

**PREMIER REVÊTEMENT** en polyester expansé accouplé à chaud à un velours accrochant en polyester et/ou ouate de polyester à 100% de 200g.

**PANNEAUX DE FOND COFFRE** rangement de 12-14mm en particules de bois de peuplier classe E1.

**MASSIVES** Tannenholz und/oder Blöcke aus Pappelmeerschholz.

**SPANPLATTEN** aus Pappelholz mit 18/25 mm Schichtdicke der Klasse E1, geringer Formaldehydabgabe und natürlichen Holzfasern.

**POLYURETHANSCHAUM** mit Dichten von 18 kg/m<sup>3</sup> bis 40 kg/m<sup>3</sup>. Kissen mit Watte zu 300 g überzogen.

**ERSTER ÜBERZUG** aus Polyesterschaum, der auf Polyester-Samt und/oder 100% Polyesterwatte (zu 200 g) heiß aufkaschiert wurde.

**BODENPLATTEN** des Bettkastens aus 12-14 mm starken Spanplatten aus Pappelholz der Klasse E1.



Portagioie Jewelry Box Porte-bijoux Schmuckkästchen p. 542



Porta USB USB holder Port USB USB-Anschluss p. 543

## Optional

Rete / Support / Sommier / Lattenrost Pag 548



Armony (Standard)

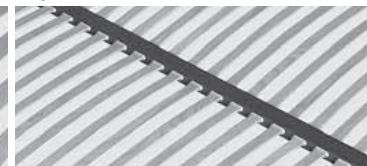

Thai 46 doghe 46 slats 46attes 46 Leisten

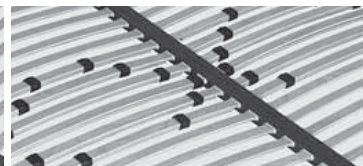

Energy Non applicabile a rete da 120 cm Not applicable to 120 cm support Non applicable au sommier de 120 cm Gilt nicht für Lattenrost zu 120 cm

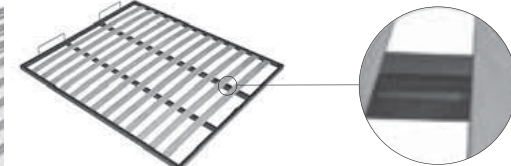

Doppio Flip Solo 140/160x190/200 - 180x200 Only 140/160x190/200 - 180x200 Uniquement 140/160x190/200 - 180x200 Nur 140/160x190/200 - 180x200

Pag 552



Sacco contenitore multiuso Multipurpose storage bag Sac coffre de rangement multi usage Mehrzweck-Aufbewahrungstasche

Pag 553



Tessuto coprirete traspirante antipolvere Support cover fabric breathable and dustproof Tissu couvre-sommier transpirant anti-poussière Atmungsaktives, vor Staub schützendes Gewebe

Pag 557



Regolatore altezza rete solo per reti in appoggio Support height adjuster only for resting frames Réglage hauteur sommier uniquement pour sommiers à poser Lattenrost-Höhenverstellung nur für aufliegende Lattenroste

Pag 556



Clean Up System

## RELAX SYSTEM

### RING EKO

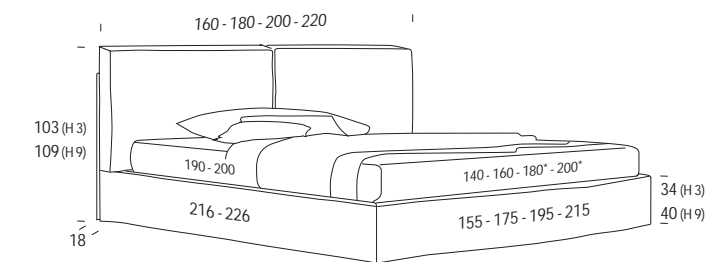
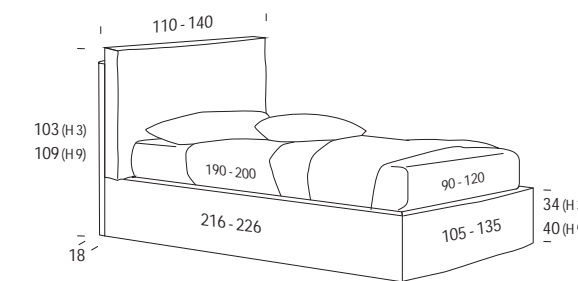

\* Rete L. 180 e L. 200 cm solo profondità 200 cm / Support W. 180 and W. 200 cm only D 200 cm / Sommier L. 180 et L. 200 cm uniquement en profondeur 200 cm / Attenrost B. 180 und B. 200 cm nur mit Tiefe 200 cm

Standard BASIC H 3 Pag 545



Wengé / Wengé / Wengé / Wengé

Pag 545



Nero / Black / Noir / Schwarz

Optional LUX H 3 Pag 545



Wengé / Wengé / Wengé / Wengé

Pag 545



Nero / Black / Noir / Schwarz

Optional VISUAL H 9 Pag 545



Wengé / Wengé / Wengé / Wengé

Pag 545



Nero / Black / Noir / Schwarz



Argento / Silver / Argent / Silber



Bianco / White / Blanc / Weiß



Cromo / Chrome / Chrome / Chrom



Bianco / White / Blanc / Weiß



Argento / Silver / Argent / Silber



Bianco / White / Blanc / Weiß

## Optional Pag 550

Meccanica / Mechanism / Mécanique / Mechanisch

Dynamic

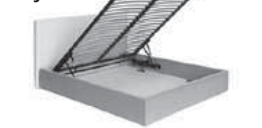

Maverick

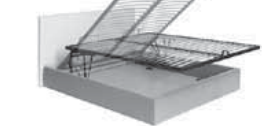

# Emily



Quello che rende unico Emily sono i grandi cuscini della testiera che possono contenere i guanciali, tenendoli al riparo dalla polvere e offrendo una posizione "seduta", per poter guardare la televisione o per poter leggere comodamente.

What makes Emily unique are the large headboard cushions, which can also hold pillows, protecting them from dust and offering a "sitting" position for watching television or reading a book in comfort.

Ce qui rend unique Emily sont les grands coussins de la tête de lit qui peuvent maintenir les oreillers à l'abri de la poussière, en permettant d'avoir une position "assise" pour regarder la télé ou lire confortablement.

Das, was Emily so einzigartig macht, sind die großen Kissen des Kopfteils, in denen sich die Kopfkissen verstauen lassen, was sie vor Staub schützt und für eine „Sitzposition“ sorgt, damit man bequem fernsehen oder lesen kann.





Testiera moderna e minimale, con particolare lavorazione sartoriale "a federa". I grandi cuscini indipendenti possono contenere i guanciali a riparo dalla polvere e sostenere posizioni più "sedute" e di comfort per la lettura, la tv.

Contemporary and minimal headboard, with particular "pillow case-like" processing. The large independent pillows can contain the night pillows to protect them from dust and allow more "seating" and comfort for reading and watching tv.

La tête de lit moderne et minimaliste, de type "oreiller". Les grands coussins indépendants peuvent maintenir les oreillers à l'abri de la poussière et avoir des positions plus "assises" et confortables pour la lecture, la télé.

Ein modernes, minimalistisches Kopfteil mit spezieller „Kissenbezug-Verarbeitung“. Die Kopfkissen lassen sich in den großen, separaten Kissen verstauen, wo sie vor Staub geschützt sind. Gleichzeitig sind „sitzendere“ Positionen möglich, die bequem zum Lesen oder Fernsehen sind.



Il giroletto elegante, a gonna con volant, può essere, all'interno, in tinta o a contrasto (optional).

The elegant bed frame, skirt-like with frills, can be, matching or contrasting on the inside (optional).

Le tour de lit élégant, à jupe à volant peut être, à l'intérieur, de la même couleur ou d'une couleur contrastée (optional).

Der elegante Bettrahmen mit seinem Volant kann in Ton-in-Ton oder in einer kontrastierenden Farbe ausgeführt werden (optional).



# Emily

COMPLETAMENTE SFODERABILE / COMPLETELY REMOVABLE FABRIC / COMPLÈTEMENT DÉHOUSSABLE / VOLLSTÄNDIG ABZIEHBAR

**MASSELLI** in legno di abete e/o scatolati in multistrato di legno di pioppo.

**PANNELLI** da 18/25 mm in particelle di legno di pioppo in classe E1 a bassa emissione di formaldeide e fibra di legno naturale.

**ESPANSI** di poliuretano in densità da 18 kg/mc a 40 kg/mc. Cuscini rivestiti in ovatta da 300 gr.

**PRIMO RIVESTIMENTO** in espanso di poliestere accoppiato a caldo a vellutino aggrappante in poliestere e/o ovatta di poliestere al 100% da 200gr.

**PANNELLI FONDO** contenitore da 12-14 mm in particelle di legno di pioppo in classe E1.

**FORGINGS** fir wood, and/or boxed in poplar plywood.

**PANELS** 18/25 mm in poplar wood particles class E1 low formaldehyde emission and natural wood fiber.

**POLYURETHANE FOAM** density from 18 kg/mc to 40 kg/mc. Cushions coated with 300 gr wadding.

**FIRST COATING** hot bonded polyester foam, velvet adhesion in polyester and/or 100% polyester wool, 200gr.

**CONTAINER BOTTOM** panels 12-14 mm in poplar wood particles class E1.

**TIGE** en pin et/ou boitiers en multicouche en bois de peuplier.

**PANNEAUX** de 18/25 mm en particules de bois de peuplier classe E1 à faible émission de formaldéhyde et fibre de bois naturelle.

**POLYURÉTHANE EXPANSÉ** densité de 18kg/m<sup>3</sup> à 40kg/m<sup>3</sup>. Coussin rembourrés avec de la ouate de 300g.

**PREMIER REVÊTEMENT** en polyester expansé accouplé à chaud à un velours accrochant en polyester et/ou ouate de polyester à 100% de 200g.

**PANNEAUX DE FOND COFFRE** rangement de 12-14mm en particules de bois de peuplier classe E1.

**MASSIVES** Tannenholz und/oder Blöcke aus Pappelmehrschichtholz.

**SPANPLATTEN** aus Pappelholz mit 18/25 mm Schichtdicke der Klasse E1, geringer Formaldehydabgabe und natürlichen Holzfasern.

**POLYURETHANSCHAUM** mit Dichten von 18 kg/m<sup>3</sup> bis 40 kg/m<sup>3</sup>. Kissen mit Watte zu 300 g überzogen.

**ERSTER ÜBERZUG** aus Polyesterschaum, der auf Polyester-Samt und/oder 100% Polyesterwatte (zu 200 g) heiß aufkaschiert wurde.

**BODENPLATTEN** des Bettkastens aus 12-14 mm starken Spanplatten aus Pappelholz der Klasse E1.



Portagioie  
Jewelry Box  
Parte-bijoux  
Schmuckkästchen  
p. 542



Porta USB  
USB holder  
Port USB  
USB-Anschluss  
p. 543

## Optional

Rete / Support / Sommier / Lattenrost Pag 548

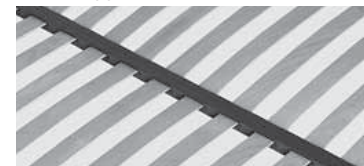

Armony  
(Standard)

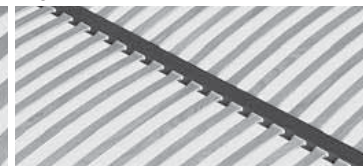

Thai  
46 doghe  
46 slats  
46 attes  
46 Leisten

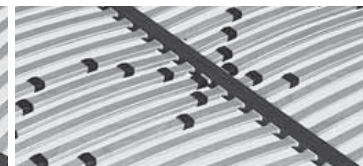

Energy  
Non applicabile a rete da 120 cm  
Not applicable to 120 cm support  
Non applicable au sommier de 120 cm  
Gilt nicht für Lattenrost zu 120 cm

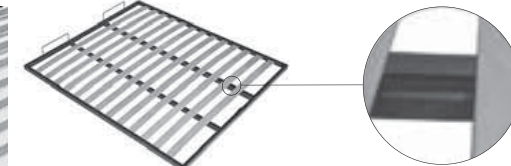

Doppio Flip  
Solo 140/160x190/200 - 180x200  
Only 140/160x190/200 - 180x200  
Uniquement 140/160x190/200 - 180x200  
Nur 140/160x190/200 - 180x200

Pag 552



Sacco contenitore multiuso  
Multipurpose storage bag  
Sac coffre de rangement multi usage  
Mehrzweck-Aufbewahrungstasche

Pag 553



Tessuto coprirete traspirante antipolvere  
Support cover fabric breathable and dustproof  
Tissu couvre-sommier respirant anti-poussière  
Atmungsaktives, vor Staub schützendes Gewebe

Pag 557



Regolatore altezza rete solo per reti in appoggio  
Support height adjuster only for resting frames  
Règlage hauteur sommier uniquement pour sommiers à poser  
Lattenrost-Höhenverstellung nur für aufliegende Lattenroste

Pag 556



Clean Up System

## RELAX SYSTEM

### RING EKO



### RING LIBERTY



Gonna in tinta  
Skirt in matching colour  
Jupe en teinte  
Ton-in-Ton ausgeführter Volant



Gonna a contrasto  
Skirt contrasting  
Jupe en contraste  
Farblich abgesetzter Volant

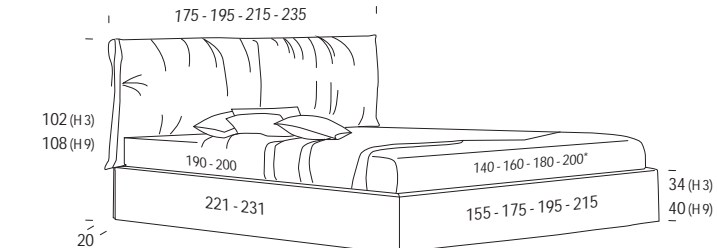
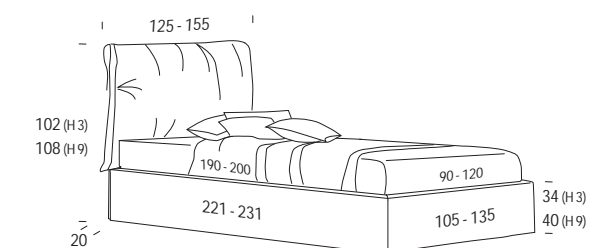

\* Rete L. 180 e L. 200 cm solo profondità 200 cm / Support W. 180 and W. 200 cm only D 200 cm  
/ Sommier L. 180 et L. 200 cm uniquement en profondeur 200 cm / Attenrost B. 180 und B. 200 cm nur mit Tiefe 200 cm

## Optional Pag 550

Meccanica / Mechanism  
/ Mécanique / Mechanisch

Dynamic



Maverick



Standard BASIC H 3



Wengé / Wengé  
/ Wengé / Wengé

Pag 545



Nero / Black  
/ Noir / Schwarz

Optional LUX H 3



Wengé / Wengé  
/ Wengé / Wengé

Pag 545



Nero / Black  
/ Noir / Schwarz

Optional VISUAL H 9



Wengé / Wengé  
/ Wengé / Wengé

Pag 545



Nero / Black  
/ Noir / Schwarz



Argento / Silver  
/ Argent / Silber



Bianco / White  
/ Blanc / Weiß



Cromo / Chrome  
/ Chrom / Chrom



Bianco / White  
/ Blanc / Weiß



Argento / Silver  
/ Argent / Silber



Bianco / White  
/ Blanc / Weiß

# Oliver



Un design contemporaneo e lineare, con un pizzico di regalità donato dalle balze arricciate in morbidi volants. Oliver porterà in ogni camera da letto un tocco lussuoso e di classe, restando elegante e aggraziato.

A linear, contemporary design, with a regal touch imparted by the softly gathered, frilled flounces. Oliver brings a touch of luxury and class to any bedroom, whilst retaining its elegance and grace.

Un design moderne et linéaire, avec une touche de royauté mise en évidence par des volants souples. Oliver apportera dans toute chambre à coucher une touche chic et luxueuse, tout en restant élégant et gracieux.

Ein modernes und geradliniges Design mit einem Touch Noblesse durch die zu weichen Rüschen gerafften Volants. Oliver bringt einen Hauch von Luxus und Klasse in jedes Schlafzimmer und bleibt dabei elegant und anmutig.









I cuscini della testiera sono lineari, arricchiti da una cornice sui lati esterni che segue il profilo della testiera. Li evidenzia e li sostiene una balza arricciata in morbidi volants. Il giroletto invece si accompagna alla tinta dei soffici cuscini.

The cushions of the headboard are linear and enriched by a frame on the outer sides which follows the edge of the headboard. It highlights and supports them a flounce curled in soft frills. The bed frame, on the other hand, matches the color of the fluffy pillows.

Les coussins de la tête de lit sont linéaires et enrichis d'un bord qui encadre le profil de la tête de lit sur les côtés externes. Ils sont mis en évidence et soutenus par des volants souples. Le tour de lit est assorti à la couleur des coussins moelleux.

Die Kissen des Kopfteils sind geradlinig und werden durch einen Rahmen an den Außenseiten ergänzt, der dem Profil des Kopfteils folgt. Sie werden durch einen weich gerafften Volant hervorgehoben und gestützt. Der Bettrahmen hingegen ist farblich auf die weichen Kissen abgestimmt.





**Relax System**  
 Grazie all'innovativa soluzione dei cuscini reclinabili molte testiere sono relax system, consentono cioè una comoda posizione "seduta" e un pratico appoggio di sostegno per leggere, guardare la tv, lavorare al laptop...

**Relax System**  
 With the innovative solution of the headboard cushions, many headboards become relaxation systems, that is, allow a comfortable position while "sitting" and a practical support for reading, watching TV, working on laptop...

**Relax System**  
 Grâce à la solution innovante des coussins tête de lit inclinable, de nombreuses tête de lits sont « relax system », elles permettent d'avoir une position assise commode et un appui pratique pour lire, regarder la télé, travailler avec l'ordinateur portable...

**Relax System**  
 Dank der innovativen Lösung mit neigbaren Kissen werden viele Kopfteile zu einem Relax-System, bieten eine bequeme „Sitzposition“ und stützen den Rücken beim Lesen, Fernsehen, Arbeiten am Laptop...

# Oliver

COMPLETAMENTE SFODERABILE / COMPLETELY REMOVABLE FABRIC / COMPLÈTEMENT DÉHOUSSABLE / VOLLSTÄNDIG ABZIEHBAR

**MASSELLI** in legno di abete e/o scatolati in multistrato di legno di pioppo.

**PANNELLI** da 18/25 mm in particelle di legno di pioppo in classe E1 a bassa emissione di formaldeide e fibra di legno naturale.

**ESPANSI** di poliuretano in densità da 18 kg/mc a 40 kg/mc. Cuscini rivestiti in ovatta da 300 gr.

**PRIMO RIVESTIMENTO** in espanso di poliestere accoppiato a caldo a vellutino aggrappante in poliestere e/o ovatta di poliestere al 100% da 200gr.

**PANNELLI FONDO** contenitore da 12-14 mm in particelle di legno di pioppo in classe E1.

**FORGINGS** fir wood, and/or boxed in poplar plywood.

**PANELS** 18/25 mm in poplar wood particles class E1 low formaldehyde emission and natural wood fiber.

**POLYURETHANE FOAM** density from 18 kg/mc to 40 kg/mc. Cushions coated with 300 gr wadding.

**FIRST COATING** hot bonded polyester foam, velvet adhesion in polyester and/or 100% polyester wool, 200gr.

**CONTAINER BOTTOM** panels 12-14 mm in poplar wood particles class E1.

**TIGE** en pin et/ou boitiers en multicouche en bois de peuplier

**PANNEAUX** de 18/25 mm en particules de bois de peuplier classe E1 à faible émission de formaldéhyde et fibre de bois naturelle.

**POLYURÉTHANE EXPANSÉ** densité de 18kg/m<sup>3</sup> à 40kg/m<sup>3</sup>. Coussin rembourrés avec de la ouate de 300g.

**PREMIER REVÊTEMENT** en polyester expansé accouplé à chaud à un velours accrochant en polyester et/ou ouate de polyester à 100% de 200g.

**PANNEAUX DE FOND COFFRE** rangement de 12-14mm en particules de bois de peuplier classe E1.

**MASSIVES** Tannenholz und/oder Blöcke aus Pappelmehrschichtholz.

**SPANPLATTEN** aus Pappelholz mit 18/25 mm Schichtdicke der Klasse E1, geringer Formaldehydabgabe und natürlichen Holzfasern.

**POLYURETHANSCHAUM**, nicht verformbar und mit differenzierter Tragfähigkeit, Dichten von 18 kg/m<sup>3</sup> bis 40 kg/m<sup>3</sup>.

**ERSTER ÜBERZUG** aus Polyesterschaum, der auf Polyester-Samt und/oder 100% Polyesterwatte (zu 200 g) heiß aufkaschiert wurde.

**BODENPLATTEN** des Bettkastens aus 12-14 mm starken Spanplatten aus Pappelholz der Klasse E1.



**Portagioie**  
Jewelry Box  
Porte-bijoux  
Schmuckkästchen  
p. 542



**Porta USB**  
USB holder  
Port USB  
USB-Anschluss  
p. 543

## Optional

Rete / Support / Sommier / Lattenrost Pag 548

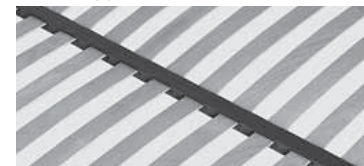

**Armony**  
(Standard)

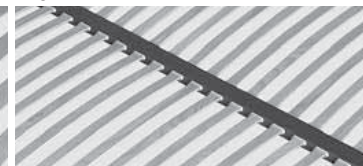

**Thai**  
46 doghe  
46 slats  
46attes  
46 Leisten

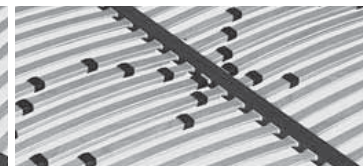

**Energy**  
Non applicabile a rete da 120 cm  
Not applicable to 120 cm support  
Non applicable au sommier de 120 cm  
Gilt nicht für Lattenrost zu 120 cm

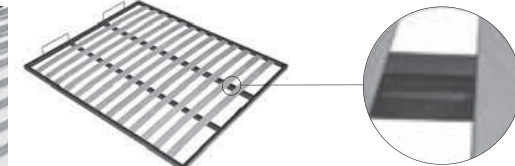

**Doppio Flip**  
Solo 140/160x190/200 - 180x200  
Only 140/160x190/200 - 180x200  
Uniquement 140/160x190/200 - 180x200  
Nur 140/160x190/200 - 180x200

Pag 552



**Sacco contenitore multiuso**  
Multipurpose storage bag  
Sac coffre de rangement multi usage  
Mehrzweck-Aufbewahrungstasche

Pag 553



**Tessuto coprirete traspirante antipolvere**  
Support cover fabric breathable and dustproof  
Tissu couvre-sommier respirant anti-poussière  
Atmungsaktives, vor Staub schützendes Gewebe

Pag 557



**Regolatore altezza rete solo per reti in appoggio**  
Support height adjuster only for resting frames  
Règlage hauteur sommier uniquement pour sommiers à poser  
Lattenrost-Höhenverstellung nur für aufliegende Lattenroste

Pag 556



**Clean Up System**

## RELAX SYSTEM

### RING EKO



### RING LIBERTY



**Gonna in tinta**  
Skirt in matching colour  
Jupe en teinte  
Ton-in-Ton ausgeführter Volant



**Gonna a contrasto**  
Skirt contrasting  
Jupe en contraste  
Farblich abgesetzter Volant

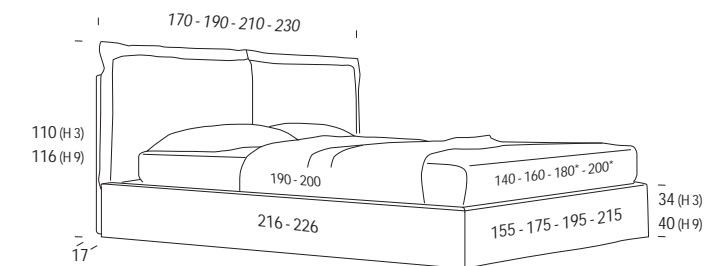
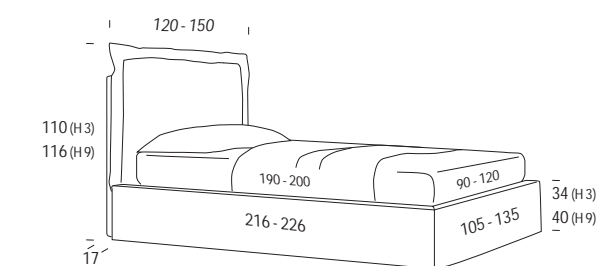

\* Rete L. 180 e L. 200 cm solo profondità 200 cm / Support W. 180 and W. 200 cm only D 200 cm  
/ Sommier L. 180 et L. 200 cm uniquement en profondeur 200 cm / Attenrost B. 180 und B. 200 cm nur mit Tiefe 200 cm

## Optional Pag 550

Meccanica / Mechanism  
/ Mécanique / Mechanisch

Dynamic



Maverick



Standard BASIC H 3

Pag 545



Wengé / Wengé  
/ Wengé / Wengé



Nero / Black  
/ Noir / Schwarz

Optional LUX H 3

Pag 545



Wengé / Wengé  
/ Wengé / Wengé



Nero / Black  
/ Noir / Schwarz

Optional VISUAL H 9

Pag 545



Wengé / Wengé  
/ Wengé / Wengé



Nero / Black  
/ Noir / Schwarz



Argento / Silver  
/ Argent / Silber



Bianco / White  
/ Blanc / Weiß



Cromo / Chrome  
/ Chrome / Chrom



Bianco / White  
/ Blanc / Weiß



Argento / Silver  
/ Argent / Silber



Bianco / White  
/ Blanc / Weiß

# Timeless Collection

Timeless è la sensazione di un comfort senza tempo. Comune denominatore: un concept di letto che mette sempre al centro del progetto la persona, con le sue esigenze pratiche ed estetiche. Infinite finiture, dettagli, uno stile più classico o moderno a seconda dei gusti e dell'arredamento della camera. Timeless Collection è una raccolta di idee capaci di ispirare.

Timeless is the sensation of a timeless comfort. The common denominator is a bed concept always making the person with its practical and aesthetic needs the focus of the project. Unlimited finishings, particulars, a classic or modern style depending on the tastes and the room decor. Timeless Collection is a collection of ideas that inspire.

Timeless est la sensation d'un confort sans temps. Le dénominateur commun : un concept du lit qui met toujours au centre du projet la personne, avec ses exigences pratiques et esthétiques. Des finitions infinies, des détails, un style plus classique ou moderne selon les goûts et la décoration de la chambre à coucher. Timeless Collection est une collection d'idées capables d'inspirer.

Timeless ist das Gefühl eines zeitlosen Komforts. Gemeinsamer Nenner: ein Bettkonzept, das den Menschen mit seinen praktischen und ästhetischen Bedürfnissen immer in den Mittelpunkt des Projekts stellt. Unendlich viele Ausführungen, Details, ein eher klassischer oder moderner Stil, je nach Geschmack und Einrichtung des Zimmers. Die Timeless Collection ist eine Sammlung voller inspirierender Ideen.

# Bowie



Linee essenziali e volumi importanti per questo letto che esprime un vero e proprio concept d'arredo.

The minimalist lines and large volumes of this bed mean it really expresses the design concept.

Lignes essentielles et volumes importants pour ce lit qui exprime un véritable concept d'ameublement.

Eine schlichte Linienführung und wichtige Volumina für dieses Bett, das ein echtes Einrichtungskonzept zum Ausdruck bringt.







Nonostante il piede da 13 cm, con un semplice gesto, la rete si solleva svelando un capace contenitore all'interno del giroletto.

Despite the 13 cm leg, the bed frame lifts up with just one simple gesture, revealing a large storage space hidden inside.

Malgré le pied de 13 cm, d'un simple geste, le sommier se soulève en dévoilant un grand coffre à l'intérieur du cadre de lit.

Trotz des 13 cm hohen Fußes lässt sich der Lattenrost mit einer einfachen Geste anheben und gibt den Blick auf einen großen Stauraum im Inneren des Bettrahmens frei.







Gli elementi a bordo letto inoltre possono essere utilizzati come delle comode sedute. Optional i cuscini.

The units around the bed frame can also be used as comfortable seating. Optional seat cushions.

Les éléments au bord du lit peuvent par ailleurs être utilisés comme de pratiques sièges. En option les coussins de l'assise.

Die Randelemente können auch als bequeme Sitzgelegenheiten genutzt werden. Optionale Kissen.

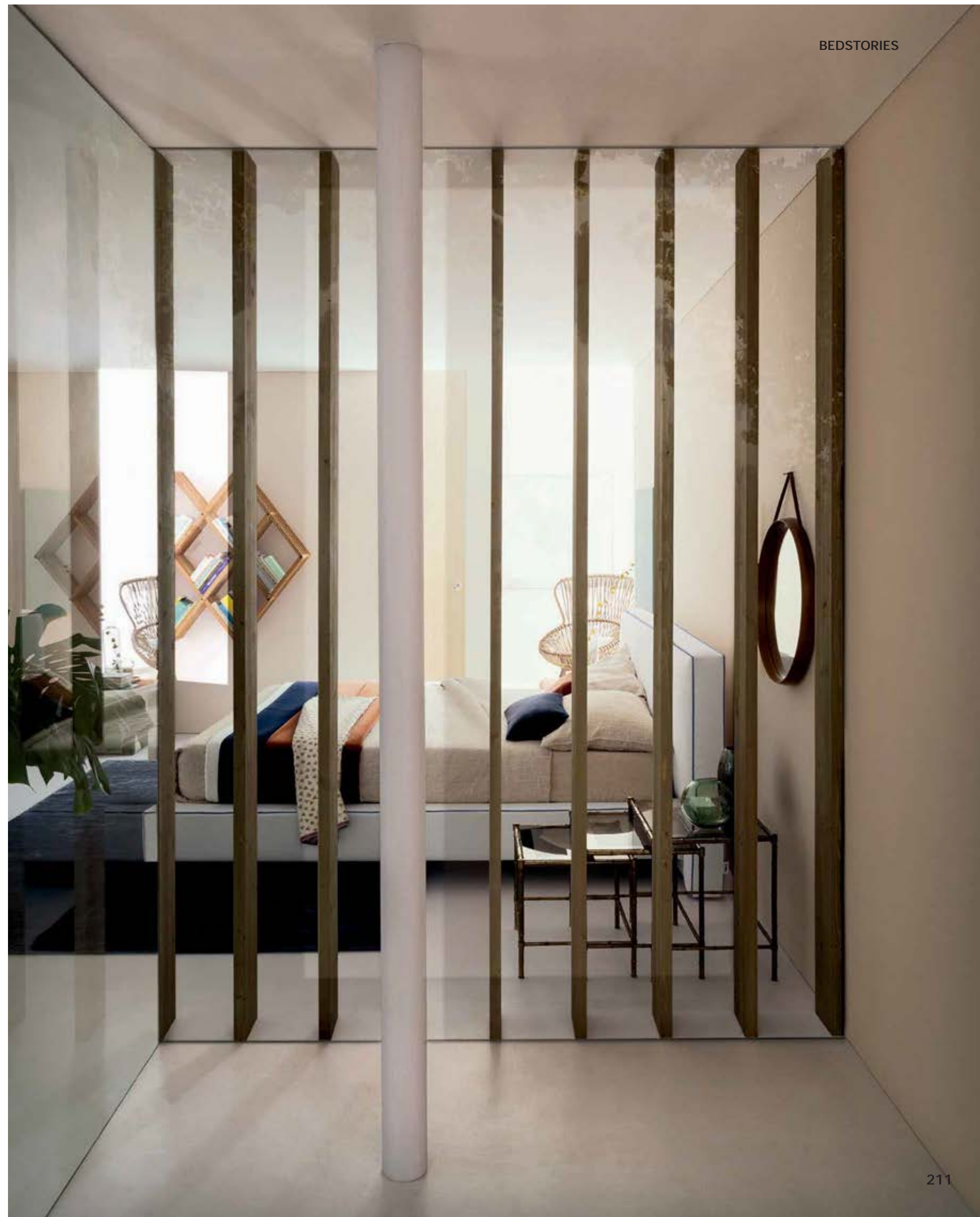





I bordi in contrasto, sottolineano le forme della testiera e del giroletto.

The contrasting piping outlines the shape of the headboard and bed frame.

Les bords en contraste soulignent les formes de la tête et du cadre de lit.

Die im Kontrast gearbeiteten Kanten betonen die Formen von Kopfteil und Bettrahmen.













I tavolini, realizzati in metallo verniciato grigio piombo, possono scorrere sul giroletto.

The painted lead-grey tables slide around the edge of the bed frame.

Les tables basses, réalisées en métal verni grigio piombo, peuvent coulisser le long du cadre de lit.

Die aus bleigrau lackiertem Metall gefertigten Tischchen lassen sich auf dem Bettrahmen verschieben.

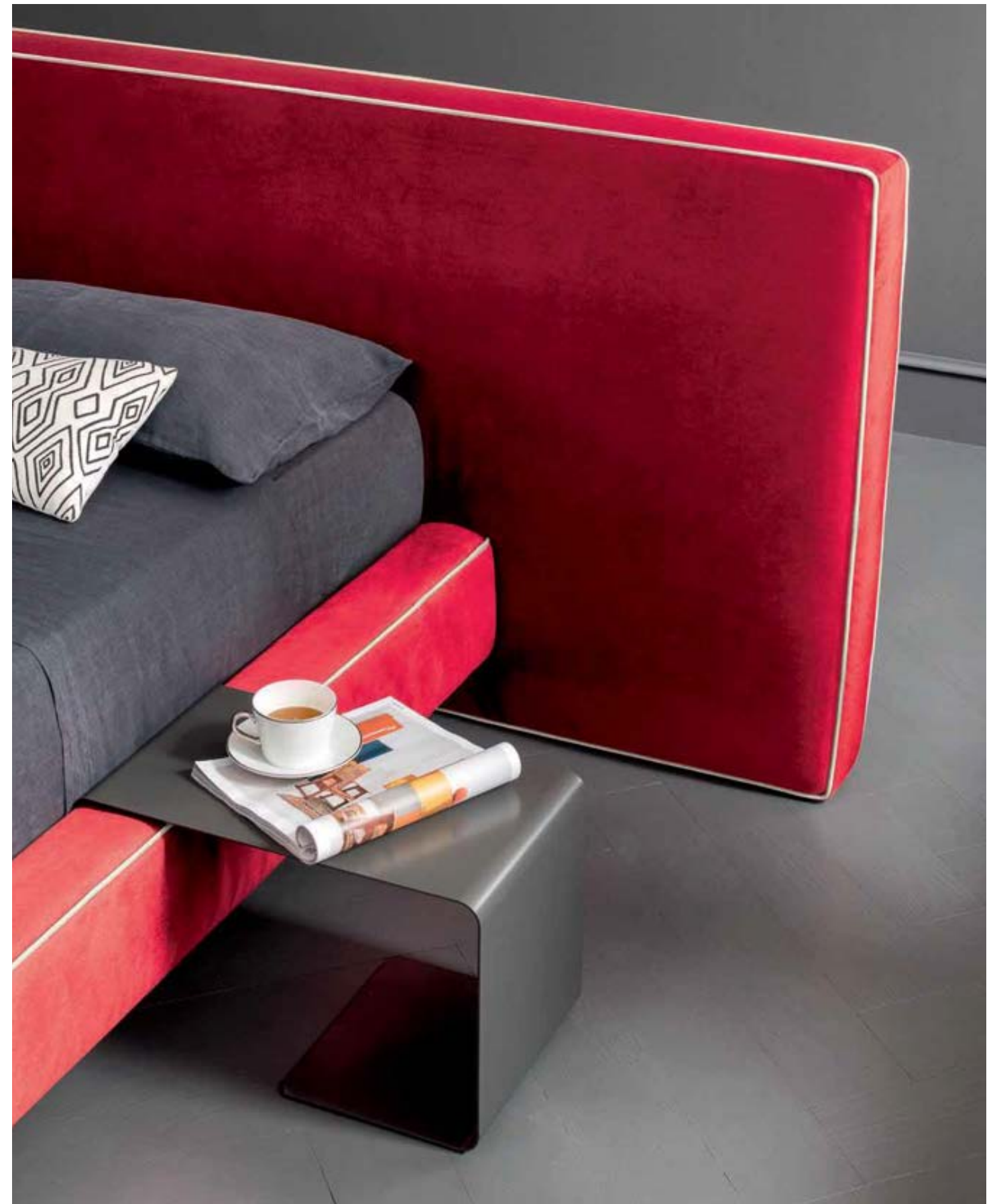



I tavolini in metallo curvato sono inseribili nel giroletto e diventano comodi, panche e sedute a seconda delle esigenze. Più funzioni quindi con design leggero e versatile. Sono disponibili a richiesta anche i cuscini a misura per l'utilizzo seduta.

The curved metal tables can be attached to the bed frame to make bedside tables, benches or seats according to need. Multiple functions, with a light and versatile design. Specifically designed cushions are available on request to use the unit as a seat.

Les tables basses en métal arrondi peuvent être insérées dans le cadre de lit et deviennent des tables de chevet, des banquettes et des sièges selon les exigences. Plusieurs fonctions donc avec un design léger et versatile. Des coussins sur mesure sont également disponibles sur demande pour l'utilisation en siège.

Die Tischchen aus gebogenen Metall lassen sich in den Bettrahmen einsetzen und werden zum Nachttisch, zur Sitzbank oder zu einer einzelnen Sitzgelegenheit, je nach Bedarf. Mehrere Funktionen bei einem leichten und vielseitigen Design. Auf Anfrage sind auch maßgearbeitete Kissen für die Nutzung als Sitzgelegenheit erhältlich.

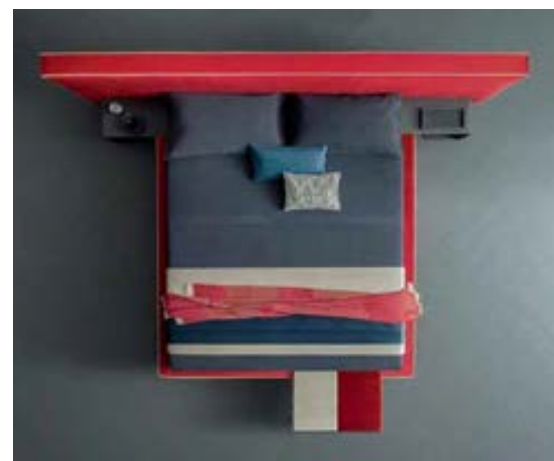

# Bowie

COMPLETAMENTE SFODERABILE / COMPLETELY REMOVABLE FABRIC / COMPLÈTEMENT DÉHOUSSABLE / VOLLSTÄNDIG ABZIEHBAR

**MASSELLI** in legno di abete e/o scatolati in multistrato di legno di pioppo.  
**PANNELLI** da 18/25 mm in particelle di legno in classe E1 a bassa emissione di formaldeide e fibra di legno naturale.  
**ESPANSI** di poliuretano indeformabile a portanza differenziata, densità da 18 kg/mc a 40 kg/mc.  
**PRIMO RIVESTIMENTO** in espanso di poliestere accoppiato a caldo a vellutino aggrappante in poliestere e/o ovatta di poliestere al 100% da 200gr.  
**PANNELLI FONDO** contenitore da 12-14 mm in particelle di legno di pioppo in classe E1.

**FORGINGS** fir wood, and/or boxed in poplar plywood.  
**PANELS** 18/25 mm in poplar wood particles class E1 low formaldehyde emission and natural wood fiber.  
**POLYURETHANE FOAM**, crushproof, of different capacity, density from 18 kg/mc to 40 kg/mc.  
**FIRST COATING** hot bonded polyester foam, velvet adhesion in polyester and/or 100% polyester wool, 200gr.  
**CONTAINER BOTTOM** panels 12-14 mm in poplar wood particles class E1.

**TIGE** en pin et/ou boitiers en multicouche en bois de peuplier.  
**PANNEAUX** de 18/25 mm en particules de bois de peuplier classe E1 à faible émission de formaldéhyde et fibre de bois naturelle.  
**POLYURÉTHANE EXPANSÉ** indéformable à portée différenciée, densité de 18kg/m<sup>3</sup> à 40kg/m<sup>3</sup>.  
**PREMIER REVÊTEMENT** en polyester expansé accouplé à chaud à un velours accrochant en polyester et/ou ouate de polyester à 100% de 200g.  
**PANNEAUX DE FOND COFFRE RANGEMENT** DE 12-14mm en particules de bois de peuplier classe E1.

**MASSIVES** Tannenholz und/oder Blöcke aus Pappelmehrschichtholz.  
**SPANPLATTEN** aus Pappelholz mit 18/25 mm Schichtdicke der Klasse E1, geringer Formaldehydabgabe und natürlichen Holzfasern.  
**POLYURETHANSCHAUM**, nicht verformbar und mit differenzierter Tragfähigkeit, Dichten von 18 kg/m<sup>3</sup> bis 40 kg/m<sup>3</sup>.  
**ERSTER ÜBERZUG** aus Polyesterschaum, der auf Polyester-Samt und/oder 100% Polyesterwatte (zu 200 g) heiß aufkaschiert wurde.  
**BODENPLATTEN** des Bettkastens aus 12-14 mm starken Spanplatten aus Pappelholz der Klasse E1.

## Bowie

Misure Testiera / Headboard measurements / Dimensions de la tête de lit / Kopfteilmaße

146 - 176 - 196 - 216 - 236 - 256



## Bowie XL

Misure Testiera / Headboard measurements / Dimensions de la tête de lit / Kopfteilmaße

278 - 298 - 318 - 338



## Optional

Rete / Support / Sommier / Lattenrost Pag 548

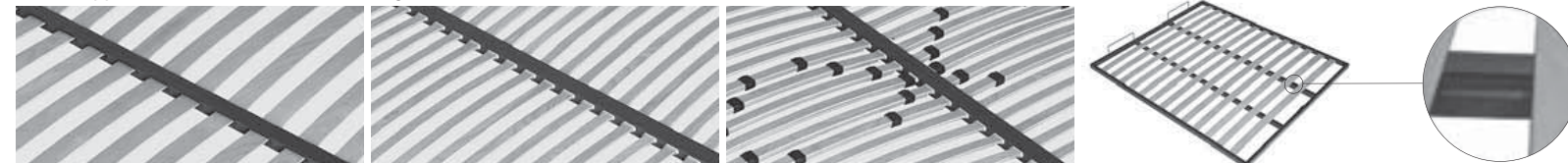

**Armony** (Standard)

**Thai**  
46 doghe  
46 slats  
46attes  
46 Leisten

**Energy**  
Non applicabile a rete da 120 cm  
Not applicable to 120 cm support  
Non applicable au sommier de 120 cm  
Gilt nicht für Lattenrost zu 120 cm

**Doppio Flip**  
Solo 140/160x190/200 - 180x200  
Only 140/160x190/200 - 180x200  
Uniquement 140/160x190/200 - 180x200  
Nur 140/160x190/200 - 180x200

Pag 552



**Sacco contenitore multiuso**  
Multipurpose storage bag  
Sac coffre de rangement multi usage  
Mehrzweck-Aufbewahrungstasche

Pag 553



**Tessuto copirete traspirante antipolvere**  
Support cover fabric breathable and dustproof  
Tissu couvre-sommier respirant anti-poussière  
Atmungsaktives, vor Staub schützendes Gewebe

Pag 557

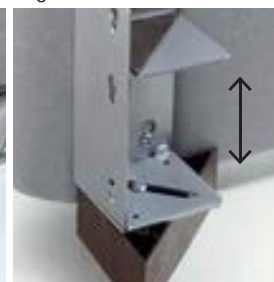

**Regolatore altezza rete solo per reti in appoggio**  
Support height adjuster only for resting frames  
Réglage hauteur sommier uniquement pour sommiers à poser  
Lattenrost-Höhenverstellung nur für aufliegende Lattenroste

Pag 554



**Tavolino metallo verniciato grigio piombo da agganciare al ring**  
Metal table to attach to bed frame, painted in lead grey  
Table basse en métal verni grigio piombo à accrocher au cadre de lit  
Bleigrau lackierter Metalltisch zur Befestigung am Bettrahmen

Pag 555



**Cuscino per tavolino/seduta optional**  
Optional table/seat cushion  
Cousin pour table basse/siège en option  
Optionales Kissen für Tisch/Sitzfläche

## Optional



**Bowie - bordo pizzicato**  
Bowie - Pinched trim  
Bowie - bord pincé  
Bowie - Kante in Pinched-Optik



**Bowie Color - bordo in tinta o contrasto**  
Bowie Color - contrasting or matching colour trim  
Bowie Color - bord en teinte ou en contraste  
Bowie Color - Ton-in-Ton oder farblich abgesetzte Kante

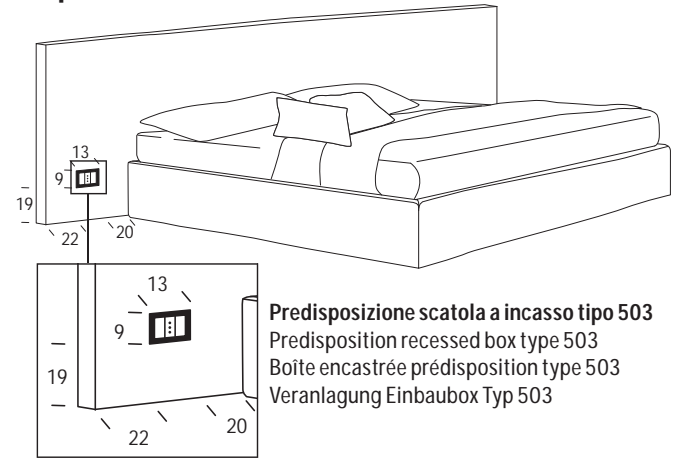

**Predisposizione scatola a incasso tipo 503**  
Predisposition recessed box type 503  
Boîte encastrée prédisposition type 503  
Veranlagung Einbaubox Typ 503

## RING YOSHI

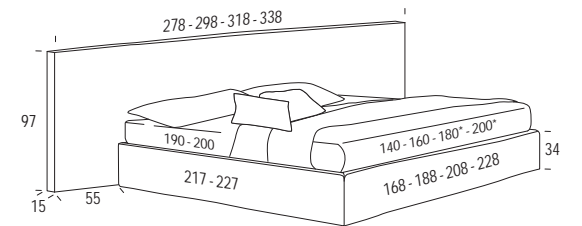
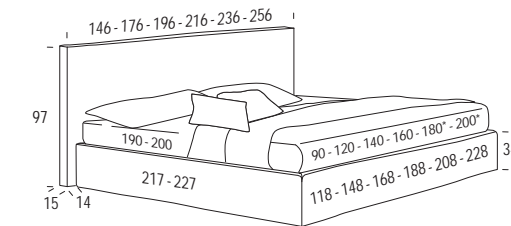

\* Rete L. 180 e L. 200 cm solo profondità 200 cm / Support W. 180 and W. 200 cm only D 200 cm / Sommier L. 180 et L. 200 cm uniquement en profondeur 200 cm / Attenrost B. 180 und B. 200 cm nur mit Tiefe 200 cm

Standard BASIC H 3 Pag 545



Wengé / Wengé / Wengé / Wengé Nero / Black / Noir / Schwarz Argento / Silver / Argent / Silber Bianco / White / Blanc / Weiß

Optional LUX H 3 Pag 545



Wengé / Wengé / Wengé / Wengé Nero / Black / Noir / Schwarz Cromo / Chrome / Chrome / Chrom Bianco / White / Blanc / Weiß

## Optional Pag 550

Meccanica / Mechanism / Mécanique / Mechanisch

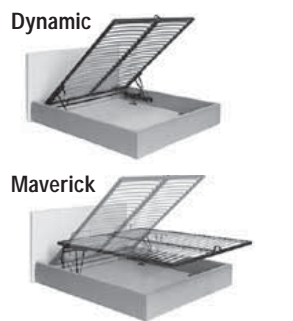

## RING KOBE



Piede a Slitta H 13 Pag 544

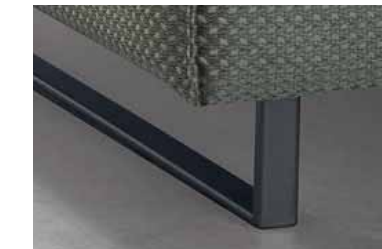

Grigio Piombo / Lead Grey / Gris Plombe / Bleigrau

\* Rete L. 180 e L. 200 cm solo profondità 200 cm / Support W. 180 and W. 200 cm only D 200 cm / Sommier L. 180 et L. 200 cm uniquement en profondeur 200 cm / Attenrost B. 180 und B. 200 cm nur mit Tiefe 200 cm

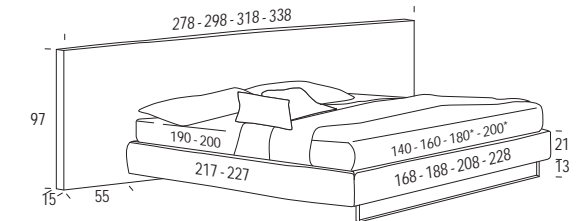
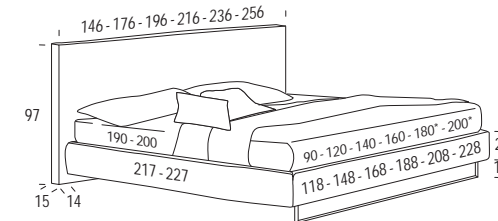

## Optional Pag 550

Meccanica / Mechanism / Mécanique / Mechanisch

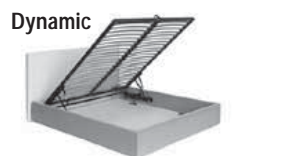

# Murphy



La testiera e la pediera, sono caratterizzate da linee sottili ed essenziali.

The headboard and footboard have a simple, sleek line.

La tête et le pied de lit sont caractérisés par des lignes fines et essentielles.

Kopf- und Fußteil zeichnen sich durch eine feine und essentielle Linienführung aus.





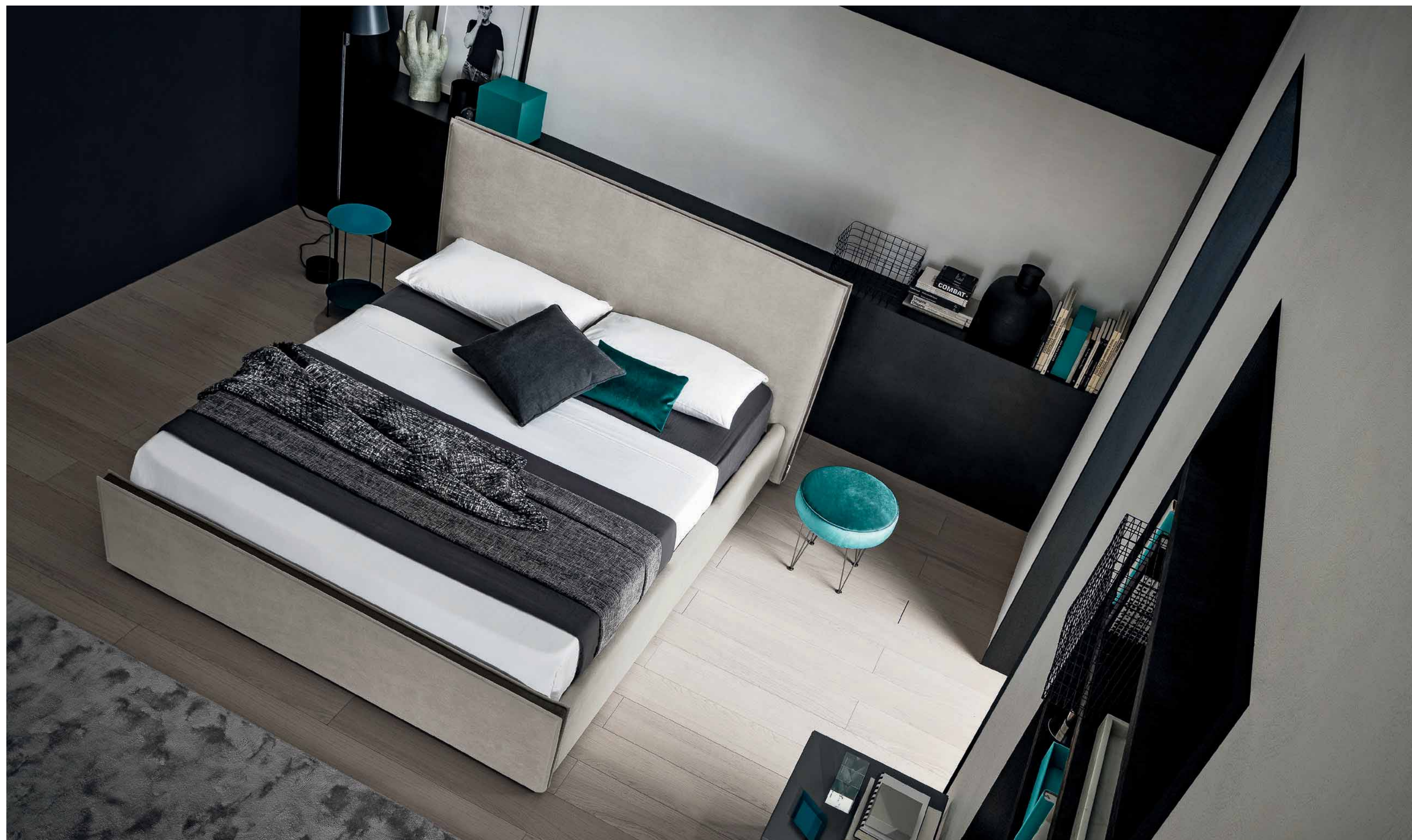



La fascia centrale in contrasto su testiera e pediera crea un gioco visivo caratterizzante.

The contrasting central strip around the headboard and footboard creates a characteristic, visual effect.

La bande centrale en contraste sur tête et pied de lit crée un jeu visuel caractérisant.

Der farblich abgesetzte Mittelstreifen an Kopf- und Fußteil sorgt für einen besonderen optischen Effekt.

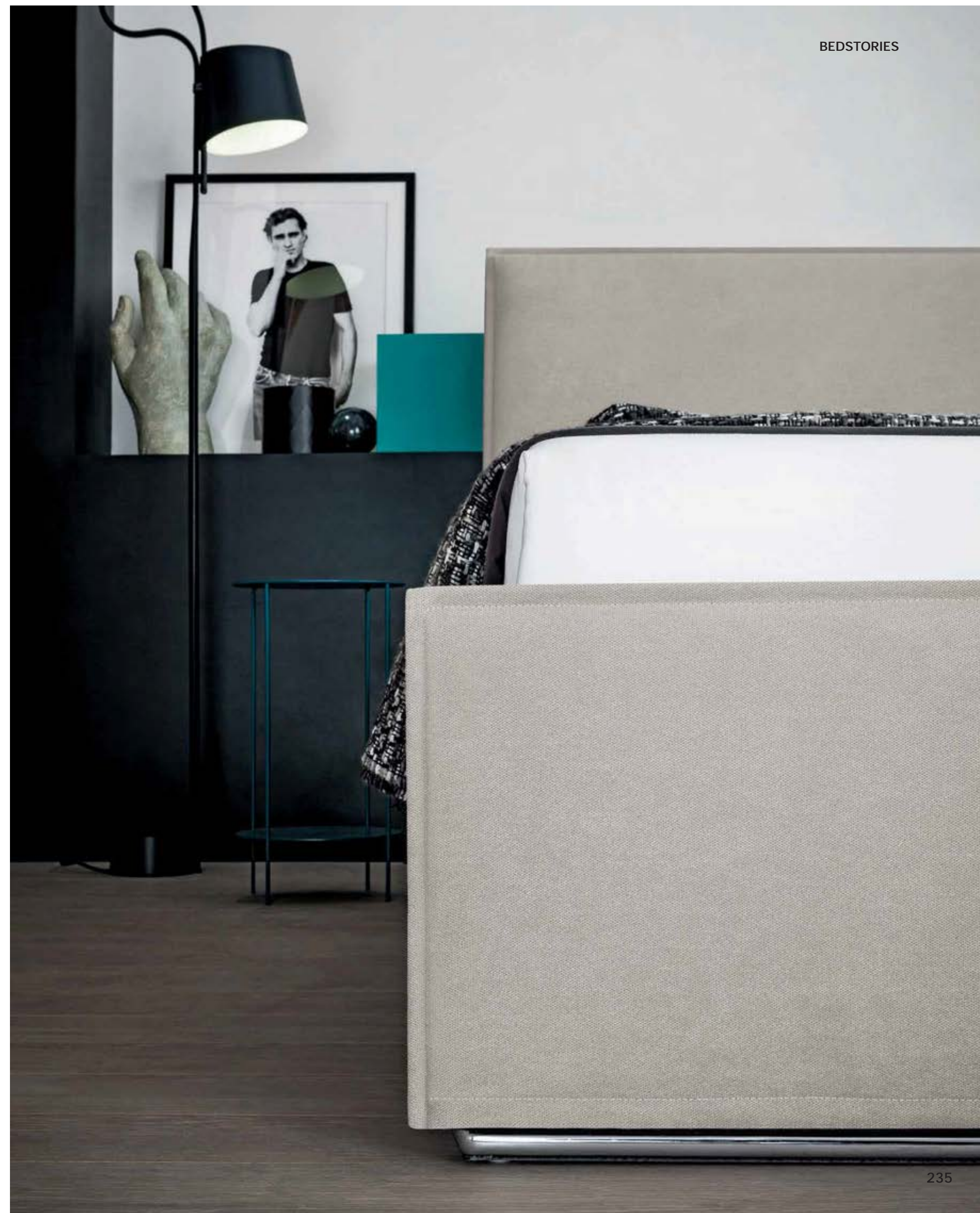





# Murphy

COMPLETAMENTE SFODERABILE / COMPLETELY REMOVABLE FABRIC / COMPLÈTEMENT DÉHOUSSABLE / VOLLSTÄNDIG ABZIEHBAR

**MASSELLI** in legno di abete e/o scatolati in multistrato di legno di pioppo.

**PANNELLI** da 18/25 mm in particelle di legno in classe E1 a bassa emissione di formaldeide e fibra di legno naturale.

**ESPANSI** di poliuretano indeformabile a portanza differenziata, densità da 18 kg/mc a 40 kg/mc.

**PRIMO RIVESTIMENTO** in espanso di poliestere accoppiato a caldo a vellutino aggrappante in poliestere e/o ovatta di poliestere al 100% da 200gr.

**PANNELLI FONDO** contenitore da 12-14 mm in particelle di legno di pioppo in classe E1.

**FORGINGS** fir wood, and/or boxed in poplar plywood.

**PANELS** 18/25 mm in poplar wood particles class E1 low formaldehyde emission and natural wood fiber.

**POLYURETHANE FOAM**, crushproof, of different capacity, density from 18 kg/mc to 40 kg/mc.

**FIRST COATING** hot bonded polyester foam, velvet adhesion in polyester and/or 100% polyester wool, 200gr.

**CONTAINER BOTTOM** panels 12-14 mm in poplar wood particles class E1.

**TIGE** en pin et/ou boitiers en multicouche en bois de peuplier.

**PANNEAUX** de 18/25 mm en particules de bois de peuplier classe E1 à faible émission de formaldéhyde et fibre de bois naturelle.

**POLYURÉTHANE EXPANSÉ** indéformable à portée différenciée, densité de 18kg/m<sup>3</sup> à 40kg/m<sup>3</sup>.

**PREMIER REVÊTEMENT** en polyester expansé accouplé à chaud à un velours accrochant en polyester et/ou ouate de polyester à 100% de 200g.

**PANNEAUX DE FOND COFFRE RANGEMENT** de 12-14mm en particules de bois de peuplier classe E1.

**MASSIVES** Tannenholz und/oder Blöcke aus Pappelmehrschichtholz.

**SPANPLATTEN** aus Pappelholz mit 18/25 mm Schichtdicke der Klasse E1, geringer Formaldehydabgabe und natürlichen Holzfasern.

**POLYURETHANSCHAUM**, nicht verformbar und mit differenzierter Tragfähigkeit, Dichten von 18 kg/m<sup>3</sup> bis 40 kg/m<sup>3</sup>.

**ERSTER ÜBERZUG** aus Polyesterschaum, der auf Polyester-Samt und/oder 100% Polyesterwatte (zu 200 g) heiß aufkaschiert wurde.

**BODENPLATTEN** des Bettkastens aus 12-14 mm starken Spanplatten aus Pappelholz der Klasse E1.



## RING HIRO

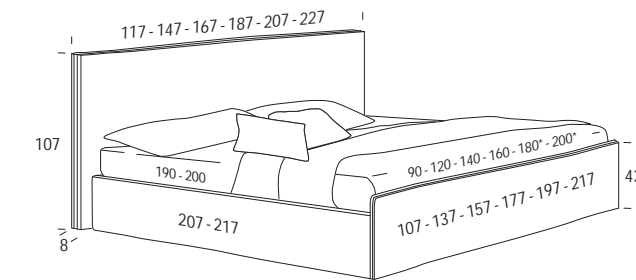

## RING SMART

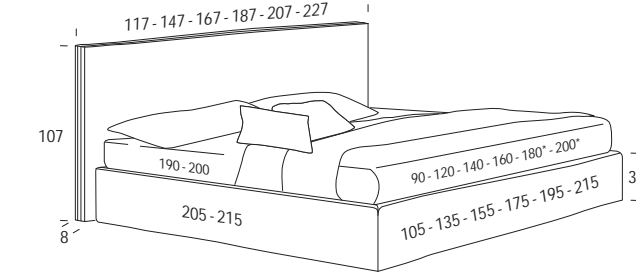

\* Rete L. 180 e L. 200 cm solo profondità 200 cm / Support W. 180 and W. 200 cm only D 200 cm / Sommier L. 180 et L. 200 cm uniquement en profondeur 200 cm / Attenrost B. 180 und B. 200 cm nur mit Tiefe 200 cm

Standard BASIC H 3

Pag 545



Wengé / Wengé / Wengé / Wengé

Nero / Black / Noir / Schwarz

Argento / Silver / Argent / Silber

Bianco / White / Blanc / Weiß

Optional LUX H 3

Pag 545



Wengé / Wengé / Wengé / Wengé

Nero / Black / Noir / Schwarz

Cromo / Chrome / Chrome / Chrom

Bianco / White / Blanc / Weiß

## Optional Pag 550

Meccanica / Mechanism / Mécanique / Mechanisch

Dynamic



Maverick

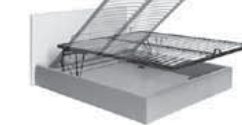

## Optional

Rete / Support / Sommier / Lattenrost Pag 548

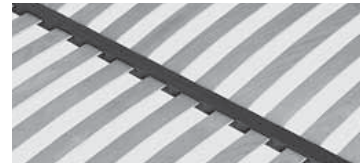

Armony (Standard)

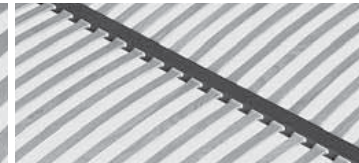

Thai 46 doghe 46 slats 46attes 46 Leisten

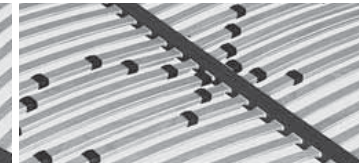

Energy Non applicabile a rete da 120 cm Not applicable to 120 cm support Non applicable au sommier de 120 cm Gilt nicht für Lattenrost zu 120 cm

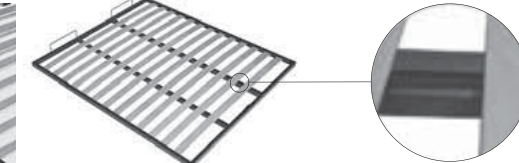

Doppio Flip Solo 140/160x190/200 - 180x200 Only 140/160x190/200 - 180x200 Uniquement 140/160x190/200 - 180x200 Nur 140/160x190/200 - 180x200

Pag 552



Sacco contenitore multiuso Multipurpose storage bag Sac coffre de rangement multi usage Mehrzweck-Aufbewahrungstasche

Pag 553



Tessuto coprirete traspirante antipolvere Support cover fabric breathable and dustproof Tissu couvre-sommier transpirant anti-poussière Atmungsaktives, vor Staub schützendes Gewebe

Pag 557



Regolatore altezza rete solo per reti in appoggio Support height adjuster only for resting frames Réglage hauteur sommier uniquement pour sommiers à poser Lattenrost-Höhenverstellung nur für aufliegende Lattenroste

Pag 556



Clean Up System

## RING YORK

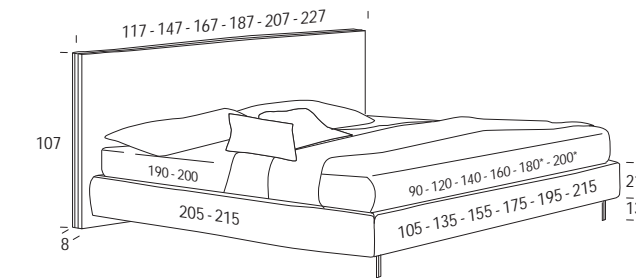

\* Rete L. 180 e L. 200 cm solo profondità 200 cm / Support W. 180 and W. 200 cm only D 200 cm / Sommier L. 180 et L. 200 cm uniquement en profondeur 200 cm / Attenrost B. 180 und B. 200 cm nur mit Tiefe 200 cm

PIEDE TWINNY a doppio stiletto H 13 / Double stiletto Twinny foot H 13

PIEDE BAOBAB in legno H 13 / Baobab wooden feet H 13

/ Pied Twinny double talon H 13 / Fußmodell Twinny mit doppeltem Stilett-Fuß H 13 Pag 544 / Pied Baobab en bois H 13 / Fußmodell Baobab aus Holz H13 Pag 544

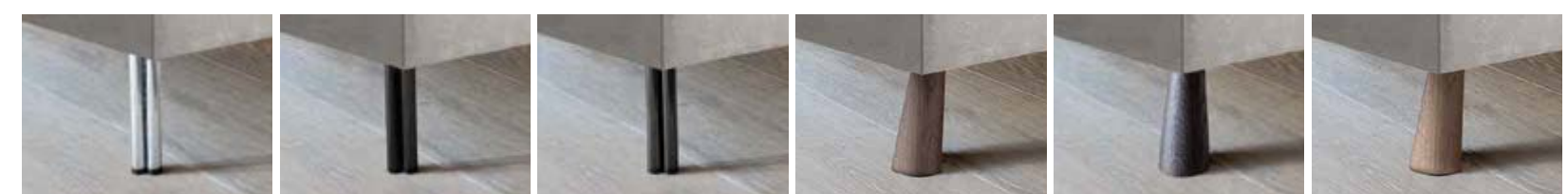

Cromo lucido Shining chrome Chrome brillant Chrom Hochglanz

Carbon look lucido Shining carbon look Carbon look brillant Carbon-Look Hochglanz

Nero opaco Mat black Noir mat Mattschwarz

Rovere Londra Dak "Londra" Chêne "Londra" Eiche "Londra"

Rovere tabacco Dak "tabacco" Chêne "tabacco" Eiche "tabacco"

Rovere naturale Dak "naturale" Chêne "naturale" Eiche "naturale"

## Optional Pag 550

Meccanica / Mechanism / Mécanique / Mechanisch

Dynamic



# Demy



Testiera e pediera imbottite, richiamano le forme della tradizione classica con la semplicità contemporanea.

The headboard and footboard are upholstered and echo classic, traditional shapes, with modern simplicity.

La tête et le pied de lit rembourrés rappellent les formes de la tradition classique avec la simplicité contemporaine.

Gepolstertes Kopf- und Fußteil, das die Formen der klassischen Tradition mit zeitgemäßer Schlichtheit in Erinnerung ruft.







Il rivestimento bicolore, con finiture di qualità artigianale, accentua la particolare personalità di questo letto.

The two-tone upholstery with artisan-quality finishes accentuates the unique personality of this bed.

Le revêtement bicolore, avec finitions de qualité artisanale, accentue la particulière personnalité de ce lit.

Der zweifarbige Bezug mit von Hand ausgeführter Endbearbeitung unterstreicht die besondere Persönlichkeit dieses Bettes.





# Demy

COMPLETAMENTE SFODERABILE / COMPLETELY REMOVABLE FABRIC / COMPLÈTEMENT DÉHOUSSABLE / VOLLSTÄNDIG ABZIEHBAR

**MASSELLI** in legno di abete e/o scatolati in multistrato di legno di pioppo.

**PANNELLI** da 18/25 mm in particelle di legno in classe E1 a bassa emissione di formaldeide e fibra di legno naturale.

**ESPANSI** di poliuretano indeformabile a portanza differenziata, densità da 18 kg/mc a 40 kg/mc.

**PRIMO RIVESTIMENTO** in espanso di poliuretano accoppiato a caldo a vellutino aggrappante in poliestere e/o ovatta di poliestere al 100% da 200gr.

**PANNELLI FONDO** contenitore da 12-14 mm in particelle di legno di pioppo in classe E1.

**FORGINGS** fir wood, and/or boxed in poplar plywood.

**PANELS** 18/25 mm in poplar wood particles class E1 low formaldehyde emission and natural wood fiber.

**POLYURETHANE FOAM**, crushproof, of different capacity, density from 18 kg/mc to 40 kg/mc.

**FIRST COATING** hot bonded polyester foam, velvet adhesion in polyester and/or 100% polyester wool, 200gr.

**CONTAINER BOTTOM** panels 12-14 mm in poplar wood particles class E1.

**TIGE** en pin et/ou boitiers en multicouche en bois de peuplier.

**PANNEAUX** de 18/25 mm en particules de bois de peuplier classe E1 à faible émission de formaldéhyde et fibre de bois naturelle.

**POLYURÉTHANE EXPANSÉ** indéformable à portée différenciée, densité de 18kg/m<sup>3</sup> à 40kg/m<sup>3</sup>.

**PREMIER REVÊTEMENT** en polyester expansé accouplé à chaud à un velours accrochant en polyester et/ou ouate de polyester à 100% de 200g.

**PANNEAUX DE FOND COFFRE RANGEMENT** de 12-14mm en particules de bois de peuplier classe E1.

**MASSIVES** Tannenholz und/oder Blöcke aus Pappelmeerschholz.

**SPANPLATTEN** aus Pappelholz mit 18/25 mm Schichtdicke der Klasse E1, geringer Formaldehydabgabe und natürlichen Holzfasern.

**POLYURETHANSCHAUM**, nicht verformbar und mit differenzierter Tragfähigkeit, Dichten von 18 kg/m<sup>3</sup> bis 40 kg/m<sup>3</sup>.

**ERSTER ÜBERZUG** aus Polyesterschaum, der auf Polyester-Samt und/oder 100% Polyesterwatte (zu 200 g) heiß aufkaschiert wurde.

**BODENPLATTEN** des Bettkastens aus 12-14 mm starken Spanplatten aus Pappelholz der Klasse E1.



## Optional

Rete / Support / Sommier / Lattenrost Pag 548

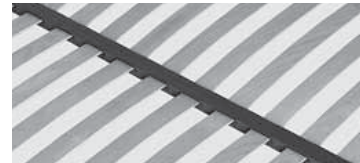

**Armony**  
(Standard)

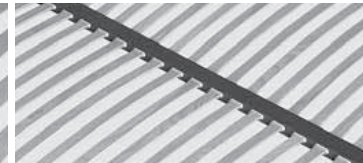

**Thai**  
46 doghe  
46 slats  
46attes  
46 Leisten

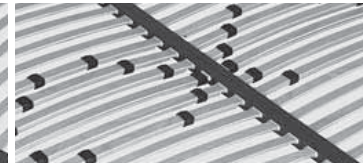

**Energy**  
Non applicabile a rete da 120 cm  
Not applicable to 120 cm support  
Non applicable au sommier de 120 cm  
Gilt nicht für Lattenrost zu 120 cm

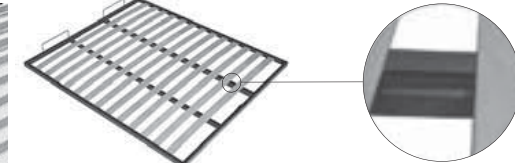

**Doppio Flip**  
Solo 140/160x190/200 - 180x200  
Only 140/160x190/200 - 180x200  
Uniquement 140/160x190/200 - 180x200  
Nur 140/160x190/200 - 180x200

Pag 552



**Sacco contenitore multiuso**  
Multipurpose storage bag  
Sac coffre de rangement multi usage  
Mehrzweck-Aufbewahrungstasche

Pag 553



**Tessuto coprirete traspirante antipolvere**  
Support cover fabric breathable and dustproof  
Tissu couvre-sommier transpirant anti-poussière  
Atmungsaktives, vor Staub schützendes Gewebe

Pag 557



**Regolatore altezza rete solo per reti in appoggio**  
Support height adjuster only for resting frames  
Réglage hauteur sommier uniquement pour sommiers à poser  
Lattenrost-Höhenverstellung nur für aufliegende Lattenroste

Pag 556



**Clean Up System**

## RING OKI



**Bordo in tinta / Matching colour trim**  
/ Bord en teinte / Ton-in-Ton Kante

**Bordo a contrasto / Contrasting trim**  
/ Bord en contraste / Farblich abgesetzte Kante

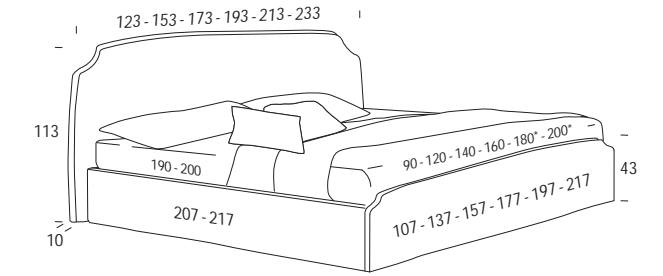

## RING SMART

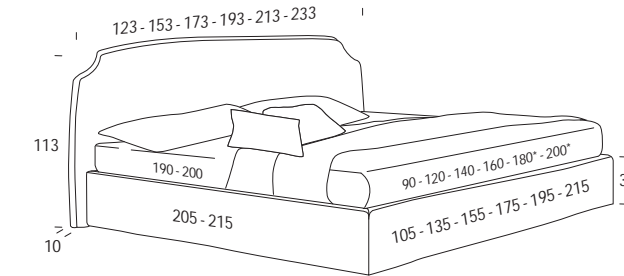

\* Rete L. 180 e L. 200 cm solo profondità 200 cm / Support W. 180 and W. 200 cm only D 200 cm  
/ Sommier L. 180 et L. 200 cm uniquement en profondeur 200 cm / Attenrost B. 180 und B. 200 cm nur mit Tiefe 200 cm

Standard BASIC H 3 Pag 545



Wengé / Wengé / Wengé / Wengé

Nero / Black / Noir / Schwarz

Argento / Silver / Argent / Silber

Bianco / White / Blanc / Weiß

Optional LUX H 3 Pag 545



Wengé / Wengé / Wengé / Wengé

Nero / Black / Noir / Schwarz

Cromo / Chrome / Chrome / Chrom

Bianco / White / Blanc / Weiß

## Optional Pag 550

Meccanica / Mechanism  
/ Mécanique / Mechanisch

Dynamic



Maverick



## RING YORK

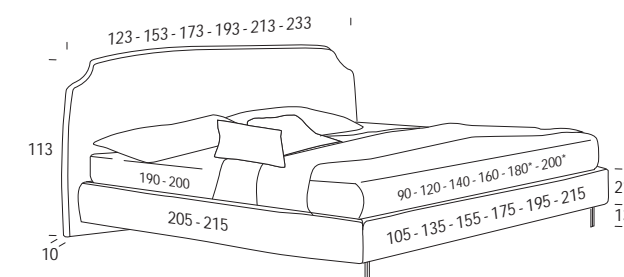

\* Rete L. 180 e L. 200 cm solo profondità 200 cm / Support W. 180 and W. 200 cm only D 200 cm  
/ Sommier L. 180 et L. 200 cm uniquement en profondeur 200 cm / Attenrost B. 180 und B. 200 cm nur mit Tiefe 200 cm

PIEDE TWINNY a doppio stiletto H 13 / Double stiletto Twinny foot H 13

PIEDE BAOBAB in legno H 13 / Baobab wooden feet H 13

/ Pied Twinny double talon H 13 / Fußmodell Twinny mit doppeltem Stilett-Fuß H 13 Pag 544 / Pied Baobab en bois H 13 / Fußmodell Baobab aus Holz H13 Pag 544



**Cromo lucido**  
Shining chrome  
Chrome brillant  
Chrom Hochglanz

**Carbon look lucido**  
Shining carbon look  
Carbon look brillant  
Carbon-Look Hochglanz

**Nero opaco**  
Mat black  
Noir mat  
Mattschwarz

**Rovere Londra**  
Dak "Londra"  
Chêne "Londra"  
Eiche "Londra"

**Rovere tabacco**  
Dak "tabacco"  
Chêne "tabacco"  
Eiche "tabacco"

**Rovere naturale**  
Dak "naturale"  
Chêne "naturale"  
Eiche "naturale"

# Megan



Un disegno morbido e accogliente, con uno spirito femminile ed aggraziato, per un ambiente nel quale abbandonarsi al relax.

A soft and welcoming bed with a gracious, feminine feel, to create a space in which to relax.

Un dessin doux et accueillant, avec un esprit féminin et gracieux, pour un espace ambiant dans lequel s'abandonner au relax.

Ein sanftes und einladendes Design mit einem femininen und anmutigen Geist, für ein Ambiente, in dem man sich entspannen kann.

BEDSTORIES









La testiera e la pediera sono impreziosite da un importante bordo in tinta o a contrasto che sottolinea il morbido design di questo letto.

The headboard and footboard are embellished with bold, coloured piping either to match or in a contrasting colour to outline this bed's soft design.

La tête et le pied de lit sont enrichis par un important bord assorti ou en contraste qui souligne le doux design de ce lit.

Kopf- und Fußteil sind mit einer bedeutenden, gleichfarbigen oder farblich abgesetzten Bordüre verziert, die das weiche Design dieses Bettes unterstreicht.



# Megan

COMPLETAMENTE SFODERABILE / COMPLETELY REMOVABLE FABRIC / COMPLÈTEMENT DÉHOUSSABLE / VOLLSTÄNDIG ABZIEHBAR

**MASSELLI** in legno di abete e/o scatolati in multistrato di legno di pioppo.

**PANNELLI** da 18/25 mm in particelle di legno in classe E1 a bassa emissione di formaldeide e fibra di legno naturale.

**ESPANSI** di poliuretano indeformabile a portanza differenziata, densità da 18 kg/mc a 40 kg/mc.

**PRIMO RIVESTIMENTO** in espanso di poliestere accoppiato a caldo a vellutino aggrappante in poliestere e/o ovatta di poliestere al 100% da 200gr.

**PANNELLI FONDO** contenitore da 12-14 mm in particelle di legno di pioppo in classe E1.

**FORGINGS** fir wood, and/or boxed in poplar plywood.

**PANELS** 18/25 mm in poplar wood particles class E1 low formaldehyde emission and natural wood fiber.

**POLYURETHANE FOAM**, crushproof, of different capacity, density from 18 kg/mc to 40 kg/mc.

**FIRST COATING** hot bonded polyester foam, velvet adhesion in polyester and/or 100% polyester wool, 200gr.

**CONTAINER BOTTOM** panels 12-14 mm in poplar wood particles class E1.

**TIGE** en pin et/ou boitiers en multicouche en bois de peuplier.

**PANNEAUX** de 18/25 mm en particules de bois de peuplier classe E1 à faible émission de formaldéhyde et fibre de bois naturelle.

**POLYURÉTHANE EXPANSÉ** indéformable à portée différenciée, densité de 18kg/m<sup>3</sup> à 40kg/m<sup>3</sup>.

**PREMIER REVÊTEMENT** en polyester expansé accouplé à chaud à un velours accrochant en polyester et/ou ouate de polyester à 100% de 200g.

**PANNEAUX DE FOND COFFRE RANGEMENT** de 12-14mm en particules de bois de peuplier classe E1.

**MASSIVES** Tannenholz und/oder Blöcke aus Pappelmehrschichtholz.

**SPANPLATTEN** aus Pappelholz mit 18/25 mm Schichtdicke der Klasse E1, geringer Formaldehydabgabe und natürlichen Holzfasern.

**POLYURETHANSCHAUM**, nicht verformbar und mit differenzierter Tragfähigkeit, Dichten von 18 kg/m<sup>3</sup> bis 40 kg/m<sup>3</sup>.

**ERSTER ÜBERZUG** aus Polyesterschaum, der auf Polyester-Samt und/oder 100% Polyesterwatte (zu 200 g) heiß aufkaschiert wurde.

**BODENPLATTEN** des Bettkastens aus 12-14 mm starken Spanplatten aus Pappelholz der Klasse E1.



## RING TAO

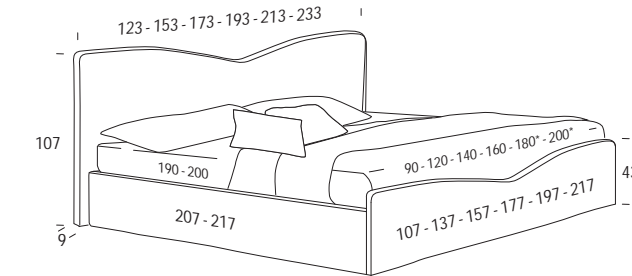

## RING SMART

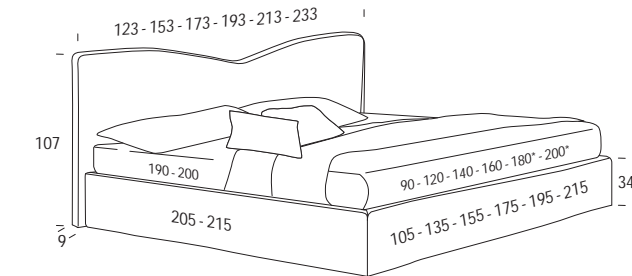

\* Rete L. 180 e L. 200 cm solo profondità 200 cm / Support W. 180 and W. 200 cm only D 200 cm / Sommier L. 180 et L. 200 cm uniquement en profondeur 200 cm / Attenrost B. 180 und B. 200 cm nur mit Tiefe 200 cm

Standard BASIC H 3 Pag 545

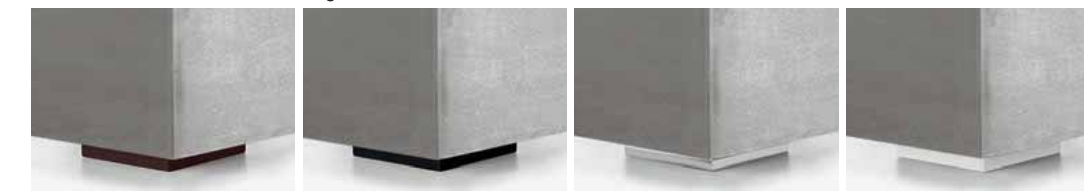

Wengé / Wengé / Wengé / Wengé Nero / Black / Noir / Schwarz Argento / Silver / Argent / Silber Bianco / White / Blanc / Weiß

Optional LUX H 3 Pag 545



Wengé / Wengé / Wengé / Wengé Nero / Black / Noir / Schwarz Cromo / Chrome / Chrome / Chrom Bianco / White / Blanc / Weiß

## Optional Pag 550

Meccanica / Mechanism / Mécanique / Mechanisch

Dynamic



Maverick

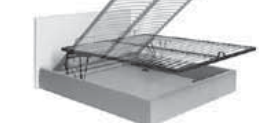

## Optional

Rete / Support / Sommier / Lattenrost Pag 548

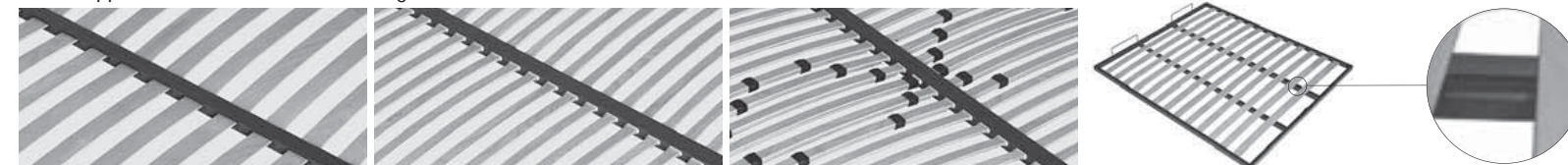

**Armony** (Standard)

**Thai**  
46 doghe  
46 slats  
46attes  
46 Leisten

**Energy**  
Non applicabile a rete da 120 cm  
Not applicable to 120 cm support  
Non applicable au sommier de 120 cm  
Gilt nicht für Lattenrost zu 120 cm

**Doppio Flip**  
Solo 140/160x190/200 - 180x200  
Only 140/160x190/200 - 180x200  
Uniquement 140/160x190/200 - 180x200  
Nur 140/160x190/200 - 180x200

Pag 552



**Sacco contenitore multiuso**  
Multipurpose storage bag  
Sac coffre de rangement multi usage  
Mehrzweck-Aufbewahrungstasche

Pag 553



**Tessuto coprirete traspirante antipolvere**  
Support cover fabric breathable and dustproof  
Tissu couvre-sommier transpirant anti-poussière  
Atmungsaktives, vor Staub schützendes Gewebe

Pag 557



**Regolatore altezza rete solo per reti in appoggio**  
Support height adjuster only for resting frames  
Réglage hauteur sommier uniquement pour sommiers à poser  
Lattenrost-Höhenverstellung nur für aufliegende Lattenroste

Pag 556



**Clean Up System**

## RING YORK

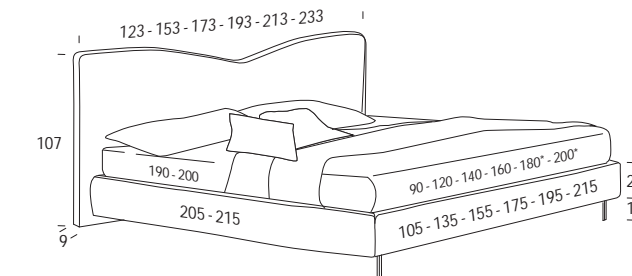

\* Rete L. 180 e L. 200 cm solo profondità 200 cm / Support W. 180 and W. 200 cm only D 200 cm / Sommier L. 180 et L. 200 cm uniquement en profondeur 200 cm / Attenrost B. 180 und B. 200 cm nur mit Tiefe 200 cm

PIEDE TWINNY a doppio stiletto H 13 / Double stiletto Twinny foot H 13

PIEDE BAOBAB in legno H 13 / Baobab wooden feet H 13

/ Pied Twinny double talon H 13 / Fußmodell Twinny mit doppeltem Stilett-Fuß H 13 Pag 544 / Pied Baobab en bois H 13 / Fußmodell Baobab aus Holz H13 Pag 544



**Cromo lucido**  
Shining chrome  
Chrome brillant  
Chrom Hochglanz

**Carbon look lucido**  
Shining carbon look  
Carbon look brillant  
Carbon-Look Hochglanz

**Nero opaco**  
Mat black  
Noir mat  
Mattschwarz

**Rovere Londra**  
Dak "Londra"  
Chêne "Londra"  
Eiche "Londra"

**Rovere tabacco**  
Dak "tabacco"  
Chêne "tabacco"  
Eiche "tabacco"

**Rovere naturale**  
Dak "naturale"  
Chêne "naturale"  
Eiche "naturale"

# Kevin

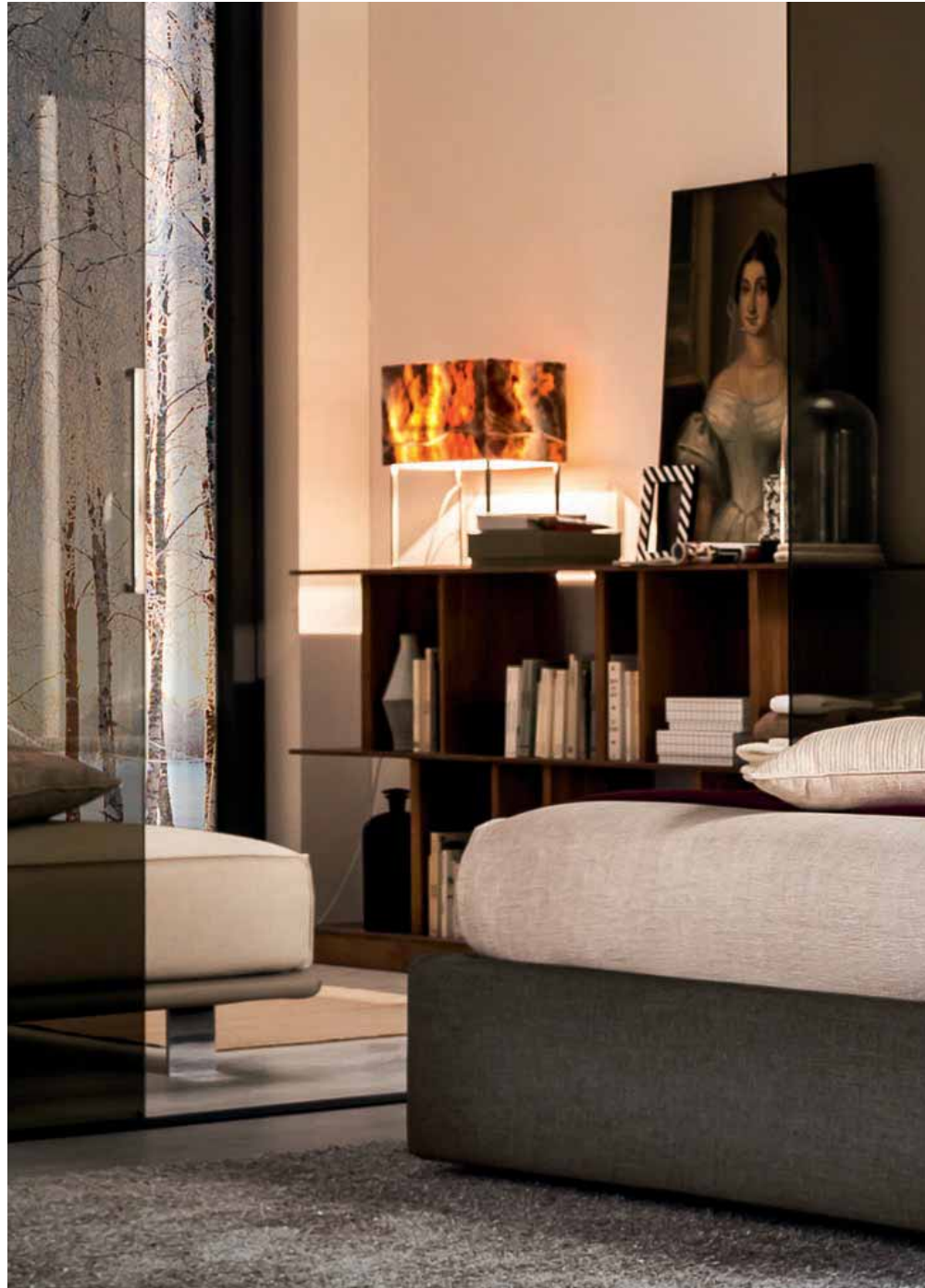

Rassicurante e comodo. Adatto a chi ama leggere o guardare la tv disteso, appoggiando la testa su un comodo cuscino facilmente sfoderabile.

Reassuring and comfortable. Suitable to those who love reading or watching TV lying down and resting their head on a comfortable cushion with easily removable cover.

Rassurant et confortable. Adapté à qui aime lire ou regarder la télévision, en appuyant la tête sur un coussin confortable facilement déhoussable.

Beruhigend und bequem. Geeignet für alle, die gerne im Liegen lesen oder fernsehen und dabei ihren Kopf auf einem bequemen Kissen mit leicht abnehmbarem Bezug ruhen lassen.



BEDSTORIA



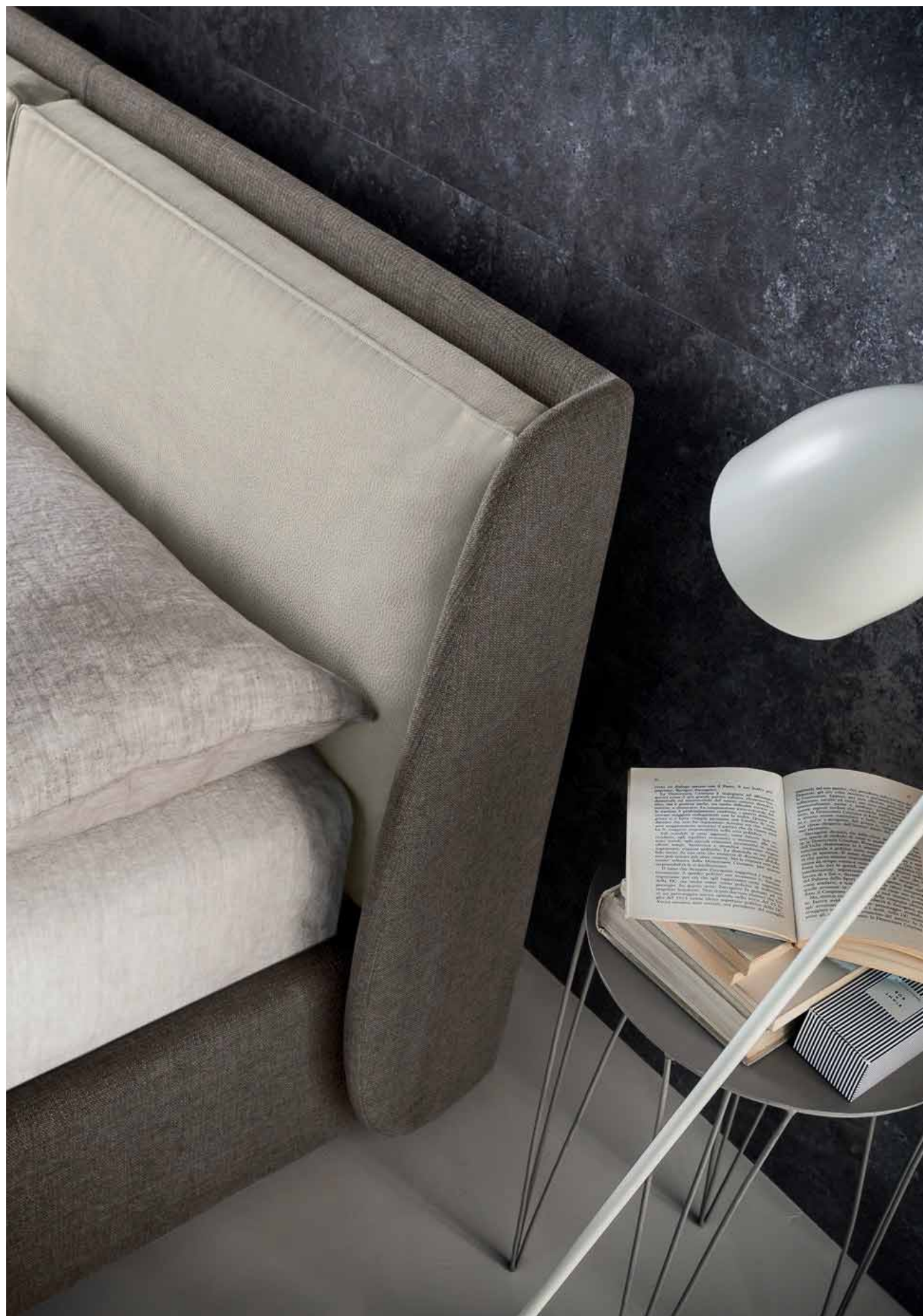





La testiera imbottita dà un effetto avvolgente e protettivo e contiene i grandi cuscini dal bordo in evidenza.  
Possibilità opzionale:  
l'illuminazione a led incorporata.

The upholstered headboard gives a cozy and protective effect and contains the large edge pillows and the bed.  
Optional possibility: integrated LED lighting.

La tête de lit rembourrée vous donne l'impression d'être enveloppés et protégés et contient les grands coussins du bord et le lit.  
En option éclairage à led incorporé.

Das gepolsterte Kopfteil sorgt für einen kuscheligen und schützenden Effekt und schließt mit seiner hervorstehenden Kante auch die großen Kissen ein.  
Mögliche Option: eingebaute LED-Beleuchtung.

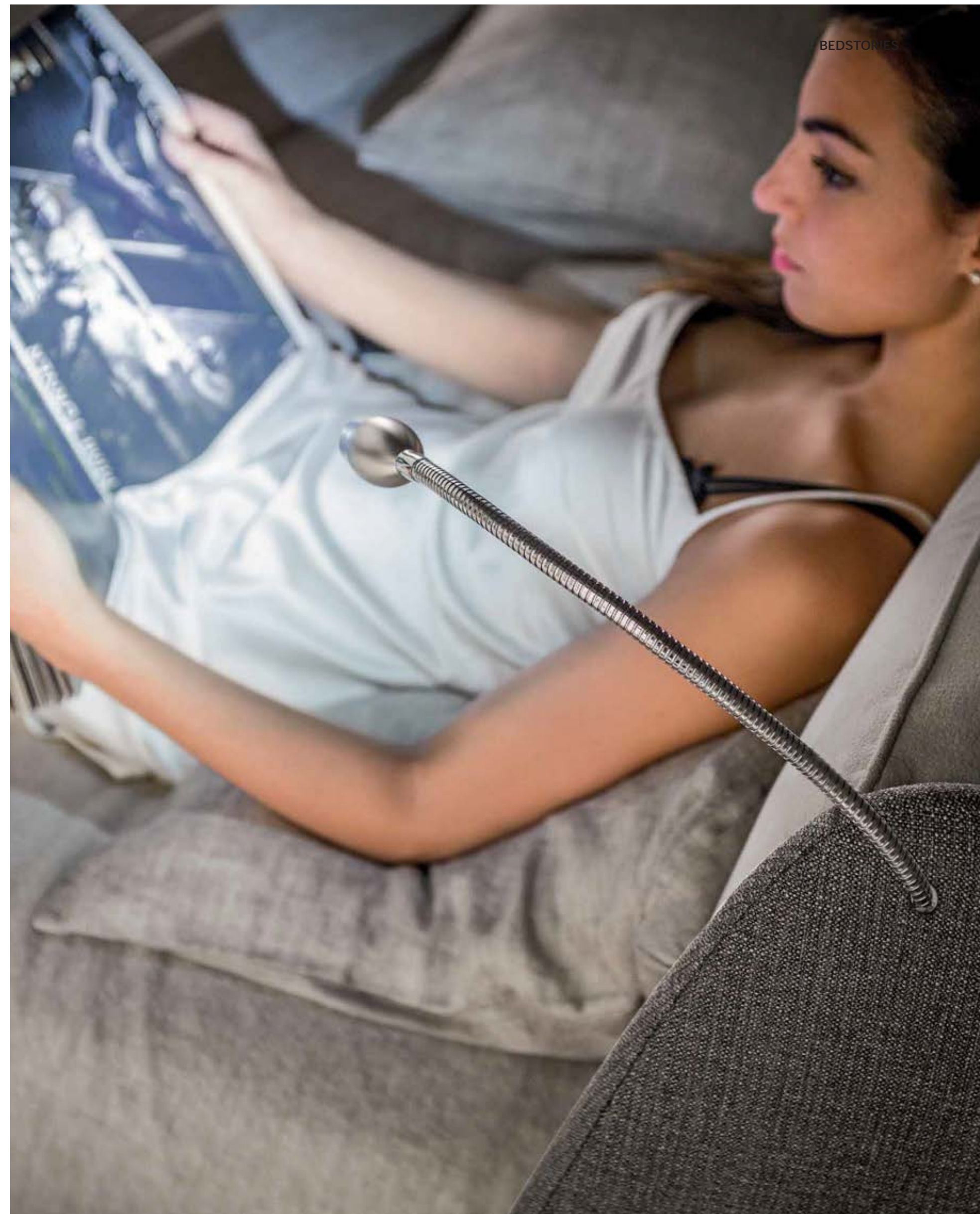





# Kevin

COMPLETAMENTE SFODERABILE / COMPLETELY REMOVABLE FABRIC / COMPLÈTEMENT DÉHOUSSABLE / VOLLSTÄNDIG ABZIEHBAR

**MASSELLI** in legno di abete e/o scatolati in multistrato di legno di pioppo.  
**PANNELLI** da 18/25 mm in particelle di legno di pioppo in classe E1 a bassa emissione di formaldeide e fibra di legno naturale.  
**ESPANSI** di poliuretano indeformabile a portanza differenziata, densità da 18 kg/mc a 40 kg/mc.  
**PRIMO RIVESTIMENTO** in espanso di poliestere accoppiato a caldo a vellutino aggrappante in poliestere e/o ovatta di poliestere al 100% da 200gr.  
**PANNELLI FONDO** contenitore da 12-14 mm in particelle di legno di pioppo in classe E1.

**FORGINGS** fir wood, and/or boxed in poplar plywood.  
**PANELS** 18/25 mm in poplar wood particles class E1 low formaldehyde emission and natural wood fiber.  
**POLYURETHANE FOAM** crushproof, of different capacity, density from 18 kg/mc to 40 kg/mc.  
**FIRST COATING** hot bonded polyester foam, velvet adhesion in polyester and/or 100% polyester wool, 200gr.  
**CONTAINER BOTTOM** panels 12-14 mm in poplar wood particles class E1.

**TIGE** en pin et/ou boitiers en multicouche en bois de peuplier  
**PANNEAUX** de 18/25 mm en particules de bois de peuplier classe E1 à faible émission de formaldéhyde et fibre de bois naturelle.  
**POLYURÉTHANE EXPANSÉ** indéformable à portée différenciée, densité de 18kg/m<sup>3</sup> à 40kg/m<sup>3</sup>.  
**PREMIER REVÊTEMENT** en polyester expansé accouplé à chaud à un velours accrochant en polyester et/ou ouate de polyester à 100% de 200g.  
**PANNEAUX DE FOND COFFRE** rangement de 12-14mm en particules de bois de peuplier classe E1.

**MASSIVES** Tannenholz und/oder Blöcke aus Pappelmehrschichtholz.  
**SPANPLATTEN** aus Pappelholz mit 18/25 mm Schichtdicke der Klasse E1, geringer Formaldehydabgabe und natürlichen Holzfasern.  
**POLYURETHANSCHAUM**, nicht verformbar und mit differenzierter Tragfähigkeit, Dichten von 18 kg/m<sup>3</sup> bis 40 kg/m<sup>3</sup>.  
**ERSTER ÜBERZUG** aus Polyesterschaum, der auf Polyester-Samt und/oder 100% Polyesterwatte (zu 200 g) heiß aufkaschiert wurde.  
**BODENPLATTEN** des Bettkastens aus 12-14 mm starken Spanplatten aus Pappelholz der Klasse E1.



illuminazione / Lighting / Éclairage / Beleuchtung p. 541



Portagioie / Jewelry Box / Porte-bijoux / Schmuckkästchen p. 542



Porta USB / USB holder / Port USB / USB-Anschluss p. 543

## Optional

Rete / Support / Sommier / Lattenrost Pag 548

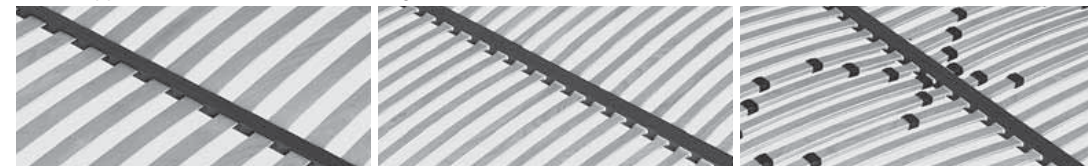

**Armony** (Standard)  
**Thai**  
 46 doghe  
 46 slats  
 46attes  
 46 Leisten

**Energy**  
 Non applicabile a rete da 120 cm  
 Not applicable to 120 cm support  
 Non applicable au sommier de 120 cm  
 Gilt nicht für Lattenrost zu 120 cm

**Doppio Flip**  
 Solo 140/160x190/200 - 180x200  
 Only 140/160x190/200 - 180x200  
 Uniquement 140/160x190/200 - 180x200  
 Nur 140/160x190/200 - 180x200

Pag 552



Sacco contenitore multiuso  
 Multipurpose storage bag  
 Sac coffre de rangement multi usage  
 Mehrzweck-Aufbewahrungstasche

Pag 553



Tessuto coprirete traspirante antipolvere  
 Support cover fabric breathable and dustproof  
 Tissu couvre-sommier respirant anti-poussière  
 Atmungsaktives, vor Staub schützendes Gewebe

Pag 557



Regolatore altezza rete solo per reti in appoggio  
 Support height adjuster only for resting frames  
 Réglage hauteur sommier uniquement pour sommiers à poser  
 Lattenrost-Höhenverstellung nur für aufliegende Lattenroste

Pag 556



Clean Up System

## RING EKO



\* Rete L. 180 e L. 200 cm solo profondità 200 cm / Support W. 180 and W. 200 cm only D 200 cm / Sommier L. 180 et L. 200 cm uniquement en profondeur 200 cm / Attenrost B. 180 und B. 200 cm nur mit Tiefe 200 cm

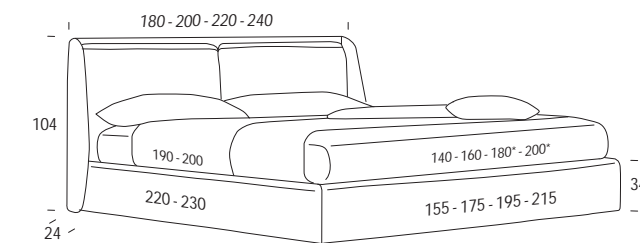

## Optional Pag 550

Meccanica / Mechanism / Mécanique / Mechanisch

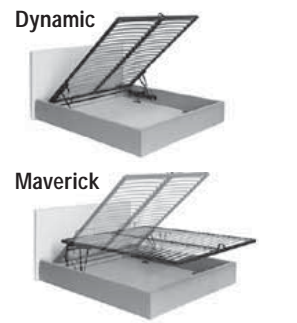

Standard BASIC H 3

Pag 545

Optional LUX H 3

Pag 545



Wengé / Wengé / Wengé / Wengé



Nero / Black / Noir / Schwarz



Wengé / Wengé / Wengé / Wengé



Nero / Black / Noir / Schwarz



Argento / Silver / Argent / Silber



Bianco / White / Blanc / Weiß



Cromo / Chrome / Chrom / Chrom



Bianco / White / Blanc / Weiß

## RING TOKYO



\* Rete L. 180 e L. 200 cm solo profondità 200 cm / Support W. 180 and W. 200 cm only D 200 cm / Sommier L. 180 et L. 200 cm uniquement en profondeur 200 cm / Attenrost B. 180 und B. 200 cm nur mit Tiefe 200 cm

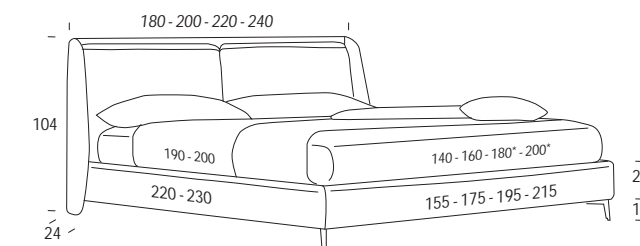

## Optional Pag 550

Meccanica / Mechanism / Mécanique / Mechanisch

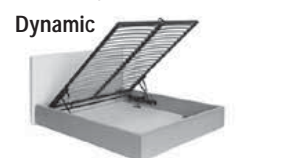

Standard BLADE H 13

Pag 546

Optional TOWER H 13

Optional PLEXY H 13

Pag 546



Satinato / Satin / Satiné / Satiniert



Bronzato / Bronze / Bronze / Bronziert



# Penny

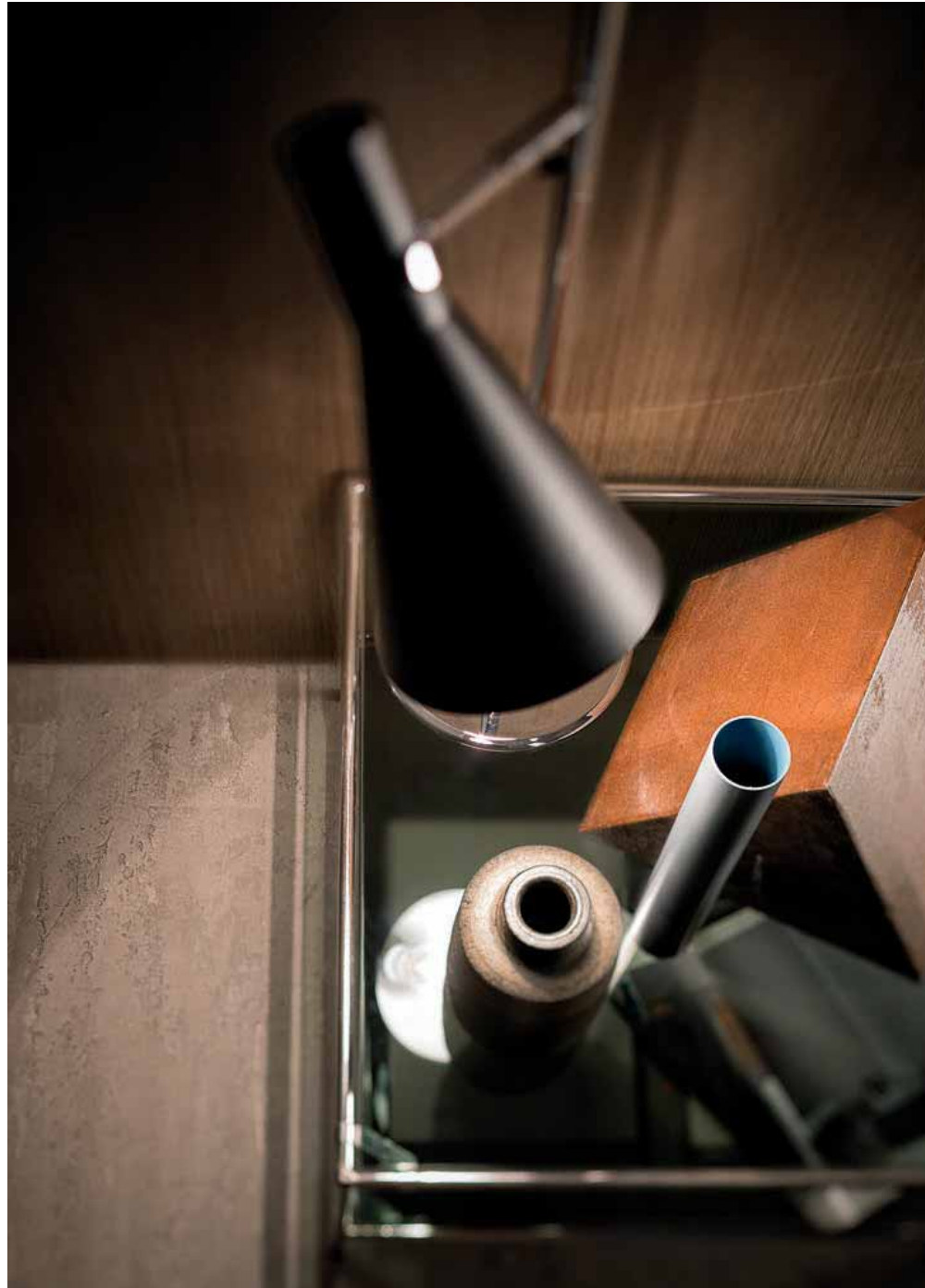

Penny interpreta un'estetica all'insegna della morbidezza. Una proposta che amplifica il senso di accoglienza caratterizzata dalla testata ampiamente imbottita. Un'isola magica spazio del comfort e rifugio rassicurante dallo stress.

Penny interpretes a look in the spirit of softness. A proposal amplifying a feeling of welcome defined by the ample padding of the headboard. A magic island - a comfy space and reassuring refuge from stress.

Penny interprète une esthétique à l'insegna de la souplesse. Une proposition qui amplifie le sens d'accueil caractérisée par une tête de lit largement rembourrée. Une île magique, espace de confort et refuge rassurant contre le stress.

Penny interpretiert eine Ästhetik, die ganz auf Weichheit basiert. Ein Modell, das das Gefühl des Willkommenseins verstärkt, das vor allem durch das breite, gepolsterte Kopfteil suggeriert wird. Eine magische Insel des Komforts und eine beruhigende Zuflucht vor Stress.



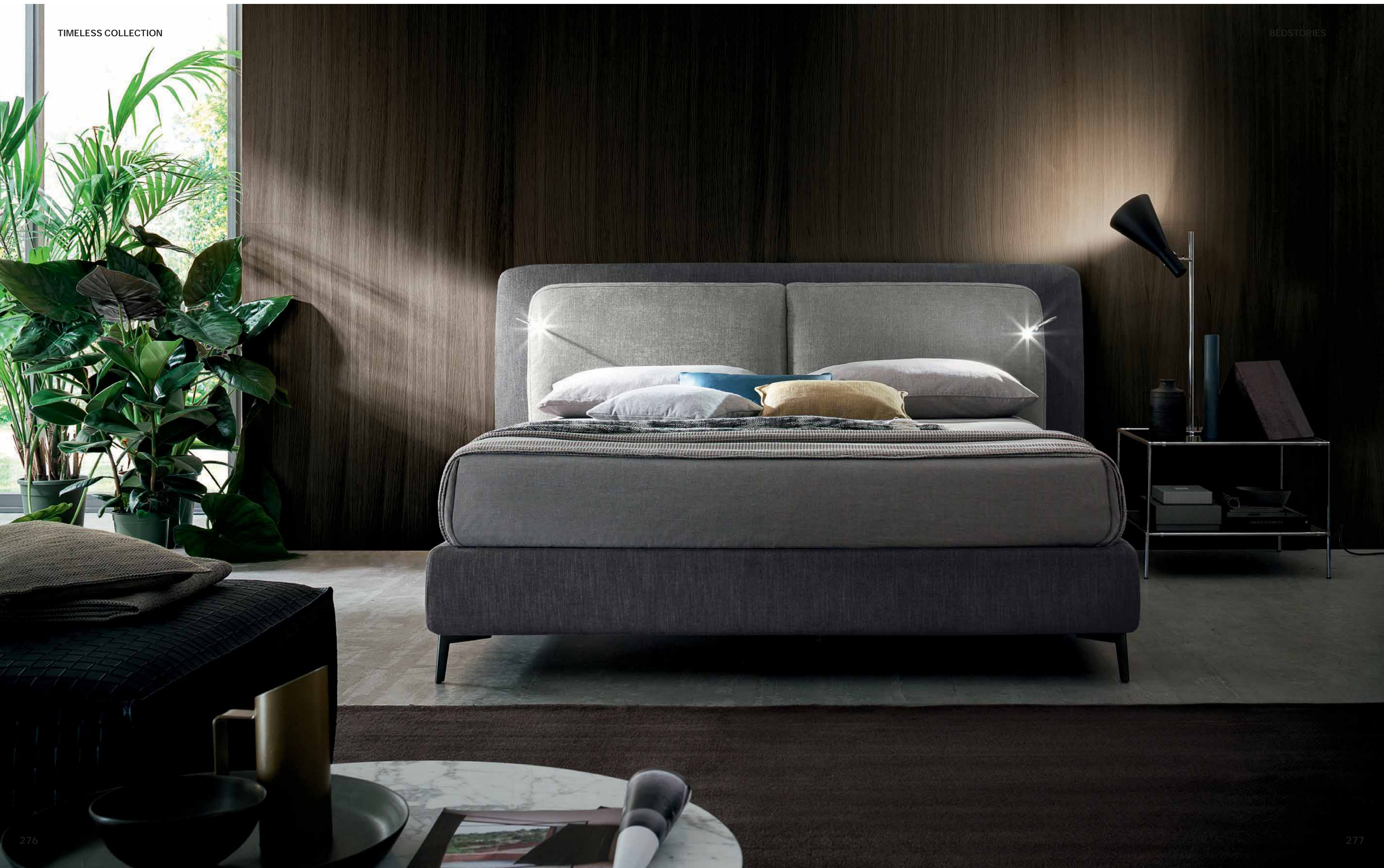

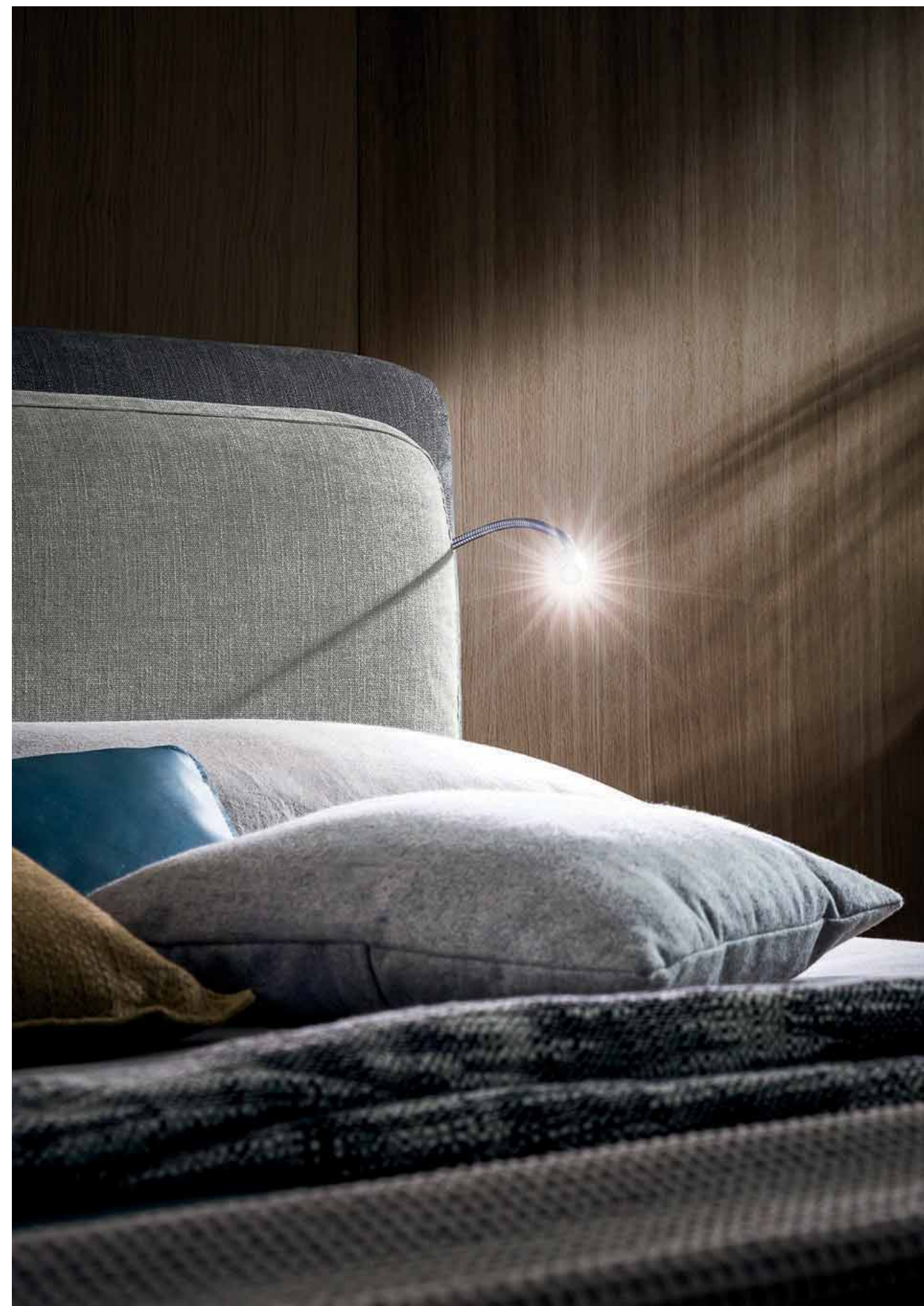

Il comodo accessorio della luce a Led orientabile inseribile nella testiera. Molto pratico nel facile azionamento "touch". Un semplice tocco sulla lampada per accendere o spegnere.

The convenient LED light accessory adjustable already in the headboard. Very practical in the easy "touch" version. A simple touch on the lamp to turn it on or off.

L'accessoire pratique de la lampe à led orientable incluse dans la tête de lit. Très pratique à commande tactile. Un simple toucher sur la lampe pour l'allumer ou l'éteindre.

Es lässt sich eine verstellbare LED-Leuchte ins Kopfteil einsetzen, die so ein praktisches Zubehörteil bildet. Sehr bequem ist auch die einfache Touch-Bedienung. Eine einfache Berührung der Leuchte genügt, um sie ein- oder auszuschalten.



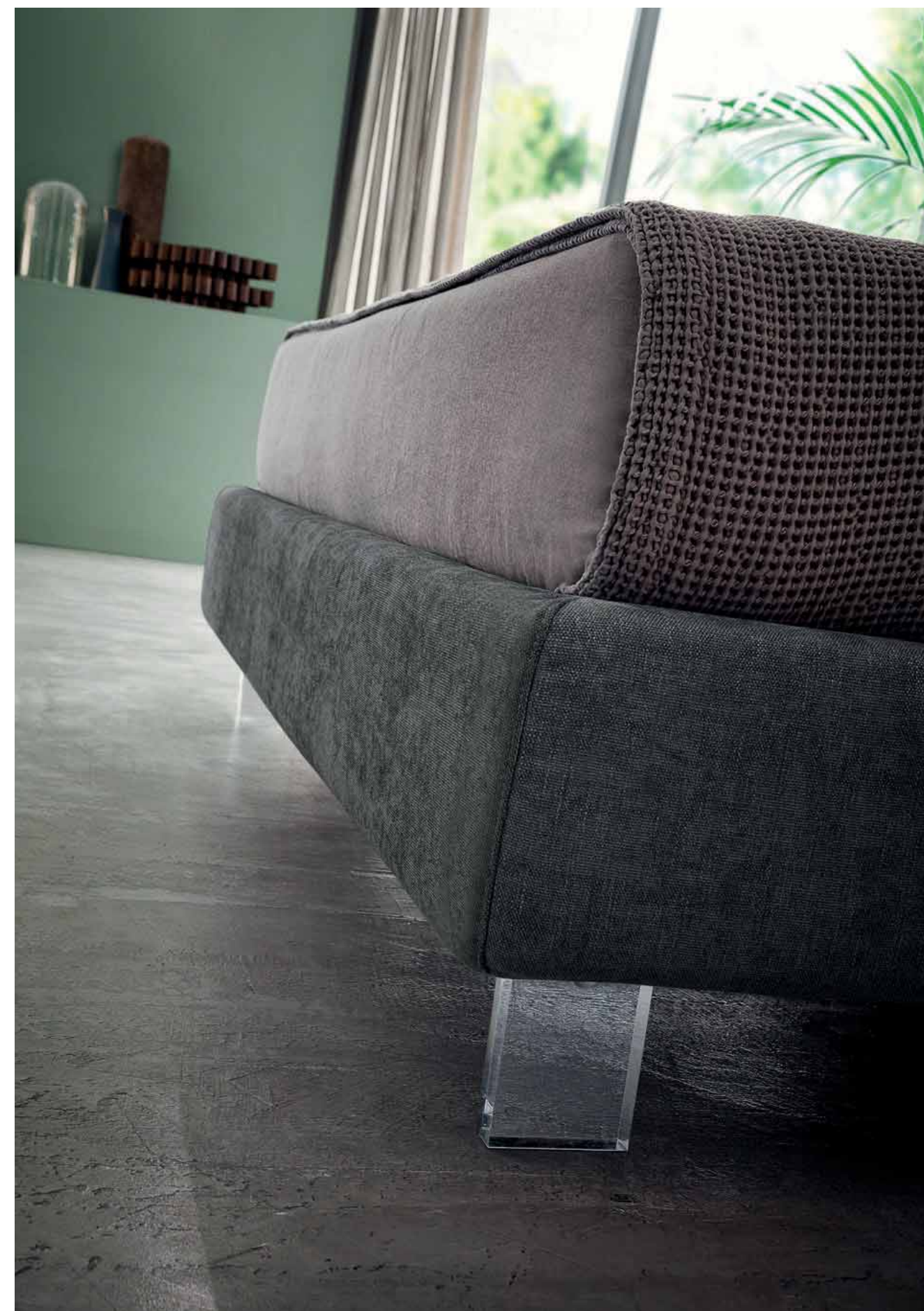

Molte soluzioni diverse di piedini per tante possibilità di abbinamento anche per il ring basso.

Many different solutions for the feet for many combination possibilities also for the low ring.

De nombreuses solutions de pieds pour les nombreuses possibilité de combinaison du tout de lit bas.

Verschiedene Fußlösungen bieten zahlreiche ombinationsmöglichkeiten, auch für das niedrige Bettgestell.

# Penny

COMPLETAMENTE SFODERABILE / COMPLETELY REMOVABLE FABRIC / COMPLÈTEMENT DÉHOUSSABLE / VOLLSTÄNDIG ABZIEHBAR

**MASSELLI** in legno di abete e/o scatolati in multistrato di legno di pioppo.  
**PANNELLI** da 18/25 mm in particelle di legno di pioppo in classe E1 a bassa emissione di formaldeide e fibra di legno naturale.  
**ESPANSI** di poliuretano indeformabile a portanza differenziata, densità da 18 kg/mc a 40 kg/mc.  
**PRIMO RIVESTIMENTO** in espanso di poliestere accoppiato a caldo a vellutino aggrappante in poliestere e/o ovatta di poliestere al 100% da 200gr.  
**PANNELLI FONDO** contenitore da 12-14 mm in particelle di legno di pioppo in classe E1.

**FORGINGS** fir wood, and/or boxed in poplar plywood.  
**PANELS** 18/25 mm in poplar wood particles class E1 low formaldehyde emission and natural wood fiber.  
**POLYURETHANE FOAM** crushproof, of different capacity, density from 18 kg/mc to 40 kg/mc.  
**FIRST COATING** hot bonded polyester foam, velvet adhesion in polyester and/or 100% polyester wool, 200gr.  
**CONTAINER BOTTOM** panels 12-14 mm in poplar wood particles class E1.

**TIGE** en pin et/ou boitiers en multicouche en bois de peuplier  
**PANNEAUX** de 18/25 mm en particules de bois de peuplier classe E1 à faible émission de formaldéhyde et fibre de bois naturelle.  
**POLYURÉTHANE EXPANSÉ** indéformable à portée différenciée, densité de 18kg/m<sup>3</sup> à 40kg/m<sup>3</sup>.  
**PREMIER REVÊTEMENT** en polyester expansé accouplé à chaud à un velours accrochant en polyester et/ou ouate de polyester à 100% de 200g.  
**PANNEAUX DE FOND COFFRE** rangement de 12-14mm en particules de bois de peuplier classe E1.

**MASSIVES** Tannenholz und/oder Blöcke aus Pappelmehrschichtholz.  
**SPANPLATTEN** aus Pappelholz mit 18/25 mm Schichtdicke der Klasse E1, geringer Formaldehydabgabe und natürlichen Holzfasern.  
**POLYURETHANSCHAUM**, nicht verformbar und mit differenzierter Tragfähigkeit, Dichten von 18 kg/m<sup>3</sup> bis 40 kg/m<sup>3</sup>.  
**ERSTER ÜBERZUG** aus Polyesterschaum, der auf Polyester-Samt und/oder 100% Polyesterwatte (zu 200 g) heiß aufkaschiert wurde.  
**BODENPLATTEN** des Bettkastens aus 12-14 mm starken Spanplatten aus Pappelholz der Klasse E1.



illuminazione  
Lighting  
Éclairage  
Beleuchtung p. 541



Portagioie  
Jewelry Box  
Porte-bijoux  
Schmuckkästchen p. 542



Porta USB  
USB holder  
Port USB  
USB-Anschluss p. 543

## Optional

Rete / Support / Sommier / Lattenrost Pag 548

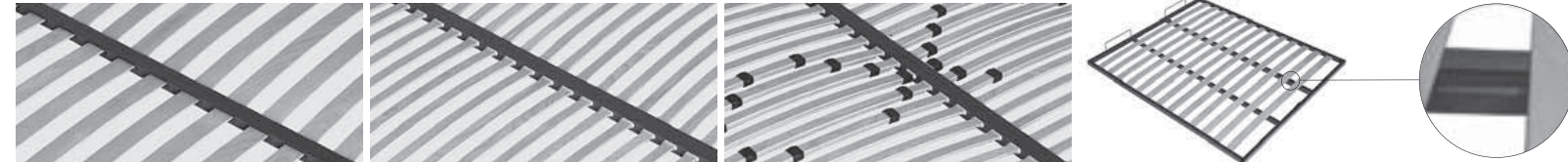

**Armony**  
(Standard)

**Thai**  
46 doghe  
46 slats  
46 attes  
46 Leisten

**Energy**  
Non applicabile a rete da 120 cm  
Not applicable to 120 cm support  
Non applicable au sommier de 120 cm  
Gilt nicht für Lattenrost zu 120 cm

**Doppio Flip**  
Solo 140/160x190/200 - 180x200  
Only 140/160x190/200 - 180x200  
Uniquement 140/160x190/200 - 180x200  
Nur 140/160x190/200 - 180x200

Pag 552



Sacco contenitore multiuso  
Multipurpose storage bag  
Sac coffre de rangement multi usage  
Mehrzweck-Aufbewahrungstasche

Pag 553



Tessuto coprirete traspirante antipolvere  
Support cover fabric breathable and dustproof  
Tissu couvre-sommier transpirant anti-poussière  
Atmungsaktives, vor Staub schützendes Gewebe

Pag 557



Regolatore altezza rete solo per reti in appoggio  
Support height adjuster only for resting frames  
Réglage hauteur sommier uniquement pour sommiers à poser  
Lattenrost-Höhenverstellung nur für aufliegende Lattenroste

Pag 556



Clean Up System

## RING EKO



\* Rete L. 180 e L. 200 cm solo profondità 200 cm / Support W. 180 and W. 200 cm only D 200 cm / Sommier L. 180 et L. 200 cm uniquement en profondeur 200 cm / Attenrost B. 180 und B. 200 cm nur mit Tiefe 200 cm

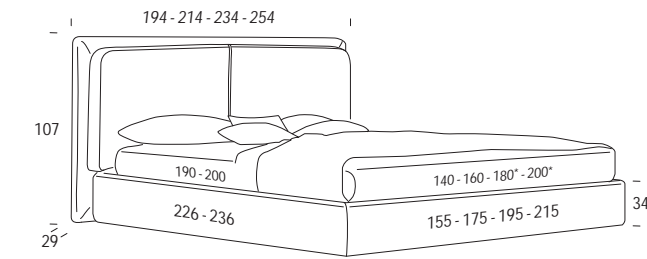

## Optional Pag 550

Meccanica / Mechanism / Mécanique / Mechanisch

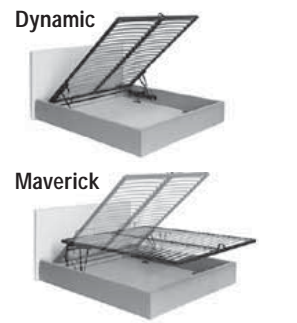

Standard BASIC H 3

Pag 545

Optional LUX H 3

Pag 545



Wengé / Wengé  
/ Wengé / Wengé



Nero / Black  
/ Noir / Schwarz



Wengé / Wengé  
/ Wengé / Wengé



Nero / Black  
/ Noir / Schwarz



Argento / Silver  
/ Argent / Silber



Bianco / White  
/ Blanc / Weiß



Cromo / Chrome  
/ Chrome / Chrom



Bianco / White  
/ Blanc / Weiß

## RING TOKYO



\* Rete L. 180 e L. 200 cm solo profondità 200 cm / Support W. 180 and W. 200 cm only D 200 cm / Sommier L. 180 et L. 200 cm uniquement en profondeur 200 cm / Attenrost B. 180 und B. 200 cm nur mit Tiefe 200 cm

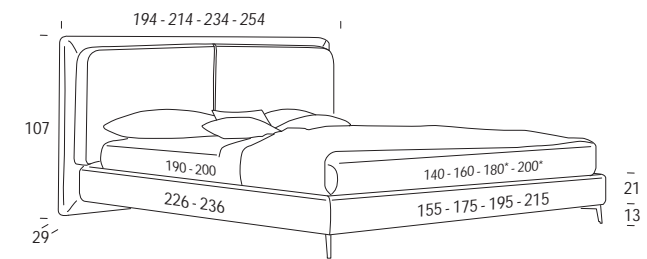

## Optional Pag 550

Meccanica / Mechanism / Mécanique / Mechanisch

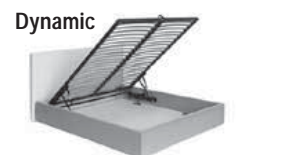

Standard BLADE H 13

Pag 546

Optional TOWER H 13

Optional PLEXY H 13

Pag 546



Satinato / Satin  
/ Satiné / Satiniert



Bronzato / Bronze  
/ Bronze / Bronziert





# Tiffany



Nove fasce di morbido tessuto si intrecciano sulla testiera dando vita ad un colorato meshwork. Tiffany offre una grande libertà compositiva: dando sfogo alla tua creatività potrai accostare sempre colori diversi rinnovando continuamente la tua camera da letto.

Nine bands of soft fabric are intertwined on the headboard creating a colourful meshwork. Tiffany offers great freedom in terms of arrangement. Unleash your creativity and mix and match different colours to continuously renew your bedroom.

Neuf bandes de tissu moelleux s'entrecroisent sur la tête de lit donnant lieu à un meshwork coloré. Tiffany donne une grande liberté de composition et la possibilité de donner libre cours à votre créativité et combiner toujours des couleurs différentes pour renouveler tout le temps votre chambre à coucher.

Neun Streifen aus weichem Stoff bilden am Kopfteil ein buntes Flechtwerk. Tiffany bietet große Gestaltungsfreiheit: wenn Sie Ihrer Kreativität freien Lauf lassen, können Sie immer verschiedene Farben kombinieren und Ihr Schlafzimmer ständig neu gestalten.

BEDSTORIES







Grande libertà di composizione. Anche in futuro se vorrai potrai sostituire dei tessuti per cambiare gli accostamenti e liberare la tua creatività.

Great freedom of composition. In the future, you will be able to replace the fabric to change the combinations and unleash your creativity.

Grande liberté de composition. Possibilité de remplacer les tissus pour changer l'assemblage et libérer la créativité.

Große Gestaltungsfreiheit. Auch in Zukunft können Sie, wenn Sie möchten, Stoffe austauschen, um die Kombinationen zu verändern und Ihrer Kreativität freien Lauf zu lassen.





Il giroletto trapuntato sempre soffice e morbido riprende il tema quadro coordinato all'intreccio delle grandi fasce di tessuto della testiera. Tutte le fasce o solo alcune possono poi essere sostituite nel tempo per avere la testiera sempre perfetta o per rinnovarla cambiando i colori.

The quilted bed frame always soft and fluffy, it reprises the theme of the framework coordinated with the interweaving of the large bands of fabric on the headboard. All the bands or some of them can then be replaced in time for an always perfect headboard or to renew it by changing colors.

Le tour de lit matelassé toujours doux et moelleux, reprend le thème carré assorti à l'entrecroisement des bandes de tissu de la tête de lit. Toutes les bandes ou certaines bandes peuvent être changées de manière à avoir toujours une tête de lit parfaite ou pour « changer » de tête de lit en changeant de couleurs.

Der gesteppte Bettrahmen, der immer weich und kuschlig ist, greift das Thema der breiten, am Kopfteil miteinander verflochtenen Streifen auf. Alle oder nur einige der Streifen können im Lauf der Zeit ausgetauscht werden, um das Kopfteil immer tadellos zu erhalten oder durch einen Farbwechsel aufzupeppen.





# Tiffany

COMPLETAMENTE SFODERABILE / COMPLETELY REMOVABLE FABRIC / COMPLÈTEMENT DÉHOUSSABLE / VOLLSTÄNDIG ABZIEHBAR

**MASSELLI** in legno di abete e/o scatolati in multistrato di legno di pioppo.  
**PANNELLI** da 18/25 mm in particelle di legno di pioppo in classe E1 a bassa emissione di formaldeide e fibra di legno naturale.  
**ESPANSI** di poliuretano indeformabile a portanza differenziata, densità da 18 kg/mc a 40 kg/mc.  
**PRIMO RIVESTIMENTO** in espanso di poliestere accoppiato a caldo a vellutino aggrappante in poliestere e/o ovatta di poliestere al 100% da 200gr.  
**PANNELLI FONDO** contenitore da 12-14 mm in particelle di legno di pioppo in classe E1.

**FORGINGS** fir wood, and/or boxed in poplar plywood.  
**PANELS** 18/25 mm in poplar wood particles class E1 low formaldehyde emission and natural wood fiber.  
**POLYURETHANE FOAM**, crushproof, of different capacity, density from 18 kg/mc to 40 kg/mc.  
**FIRST COATING** hot bonded polyester foam, velvet adhesion in polyester and/or 100% polyester wool, 200gr.  
**CONTAINER BOTTOM** panels 12-14 mm in poplar wood particles class E1

**TIGE** en pin et/ou boitiers en multicouche en bois de peuplier  
**PANNEAUX** de 18/25 mm en particules de bois de peuplier classe E1 à faible émission de formaldéhyde et fibre de bois naturelle.  
**POLYURÉTHANE EXPANSÉ** indéformable à portée différenciée, densité de 18kg/m<sup>3</sup> à 40kg/m<sup>3</sup>.  
**PREMIER REVÊTEMENT** en polyester expansé accouplé à chaud à un velours accrochant en polyester et/ou ouate de polyester à 100% de 200g.  
**PANNEAUX DE FOND COFFRE** rangement de 12-14mm en particules de bois de peuplier classe E1

**MASSIVES** Tannenholz und/oder Blöcke aus Pappelmeerschholz.  
**SPANPLATTEN** aus Pappelholz mit 18/25 mm Schichtdicke der Klasse E1, geringer Formaldehydabgabe und natürlichen Holzfasern.  
**POLYURETHANSCHAUM**, nicht verformbar und mit differenzierter Tragfähigkeit, Dichten von 18 kg/m<sup>3</sup> bis 40 kg/m<sup>3</sup>.  
**ERSTER ÜBERZUG** aus Polyesterschaum, der auf Polyester-Samt und/oder 100% Polyesterwatte (zu 200 g) heiß aufkaschiert wurde.  
**BODENPLATTEN** des Bettkastens aus 12-14 mm starken Spanplatten aus Pappelholz der Klasse E1.

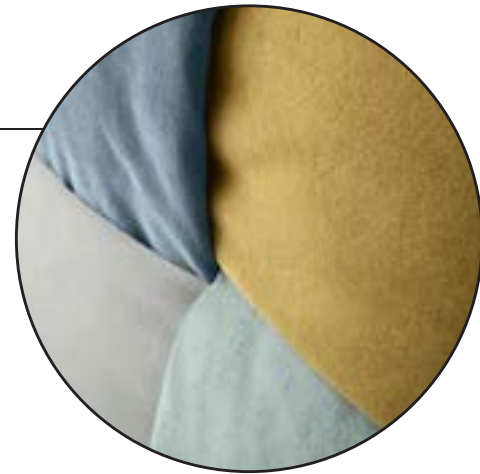

Anche successivamente all'acquisto è possibile ordinare fasce nuove o diverse per sostituzione, rinnovo parziale o totale.  
 / Even after the purchase it is possible to order new or different bands for replacement, or partial or total renewal.  
 / Après l'achat il est possible de commander de nouvelles bandes pour un remplacement partiel ou total.  
 / Auch nach dem Kauf ist es möglich, neue oder andere Streifen als Ersatz, zur teilweisen oder vollständigen Erneuerung zu bestellen.

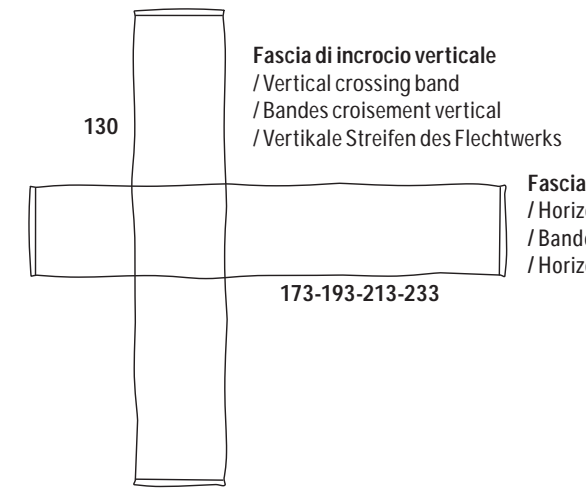

## RING PINUP

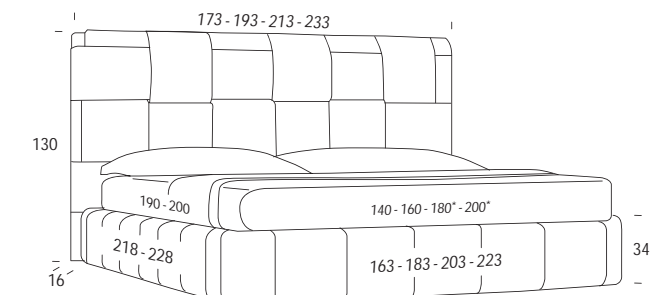

\* Rete L. 180 e L. 200 cm solo profondità 200 cm / Support W. 180 and W. 200 cm only D 200 cm  
 / Sommier L. 180 et L. 200 cm uniquement en profondeur 200 cm / Attenrost B. 180 und B. 200 cm nur mit Tiefe 200 cm

## Optional Pag 550

Meccanica / Mechanism / Mécanique / Mechanisch

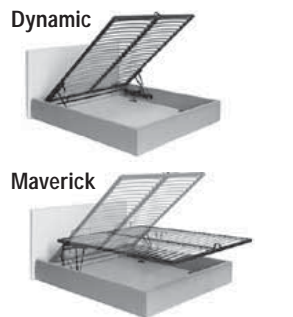

## Optional

Rete / Support / Sommier / Lattenrost Pag 548

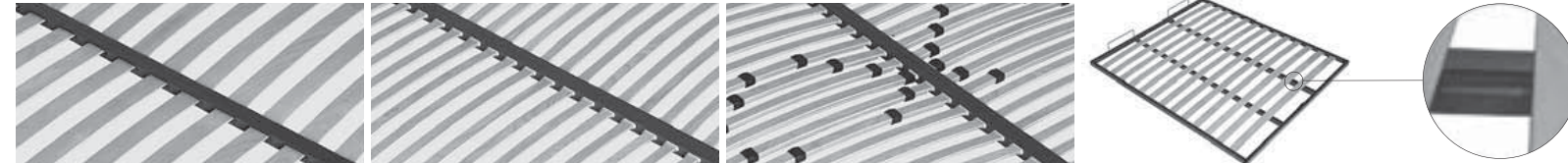

**Armony (Standard)**  
 46 doghe  
 46 slats  
 46 attes  
 46 Leisten

**Thai**  
 46 doghe  
 46 slats  
 46 attes  
 46 Leisten

**Energy**  
 Non applicabile a rete da 120 cm  
 Not applicable to 120 cm support  
 Non applicable au sommier de 120 cm  
 Gilt nicht für Lattenrost zu 120 cm

**Doppio Flip**  
 Solo 140/160x190/200 - 180x200  
 Only 140/160x190/200 - 180x200  
 Uniquement 140/160x190/200 - 180x200  
 Nur 140/160x190/200 - 180x200

Pag 552



Sacco contenitore multiuso  
 Multipurpose storage bag  
 Sac coffre de rangement multi usage  
 Mehrzweck-Aufbewahrungstasche

Pag 553



Tessuto coprirete traspirante antipolvere  
 Support cover fabric breathable and dustproof  
 Tissu couvre-sommier transpirant anti-poussière  
 Atmungsaktives, vor Staub schützendes Gewebe

Pag 557



Regolatore altezza rete solo per reti in appoggio  
 Support height adjuster only for resting frames  
 Réglage hauteur sommier uniquement pour sommiers à poser  
 Lattenrost-Höhenverstellung nur für aufliegende Lattenroste

Pag 556



Clean Up System

Standard BASIC H 3

Pag 545



Wengé / Wengé  
 / Wengé / Wengé

Nero / Black  
 / Noir / Schwarz

Optional LUX H 3

Pag 545



Wengé / Wengé  
 / Wengé / Wengé

Nero / Black  
 / Noir / Schwarz



Argento / Silver  
 / Argent / Silber



Bianco / White  
 / Blanc / Weiß



Cromo / Chrome  
 / Chrome / Chrom



Bianco / White  
 / Blanc / Weiß

# Lenny

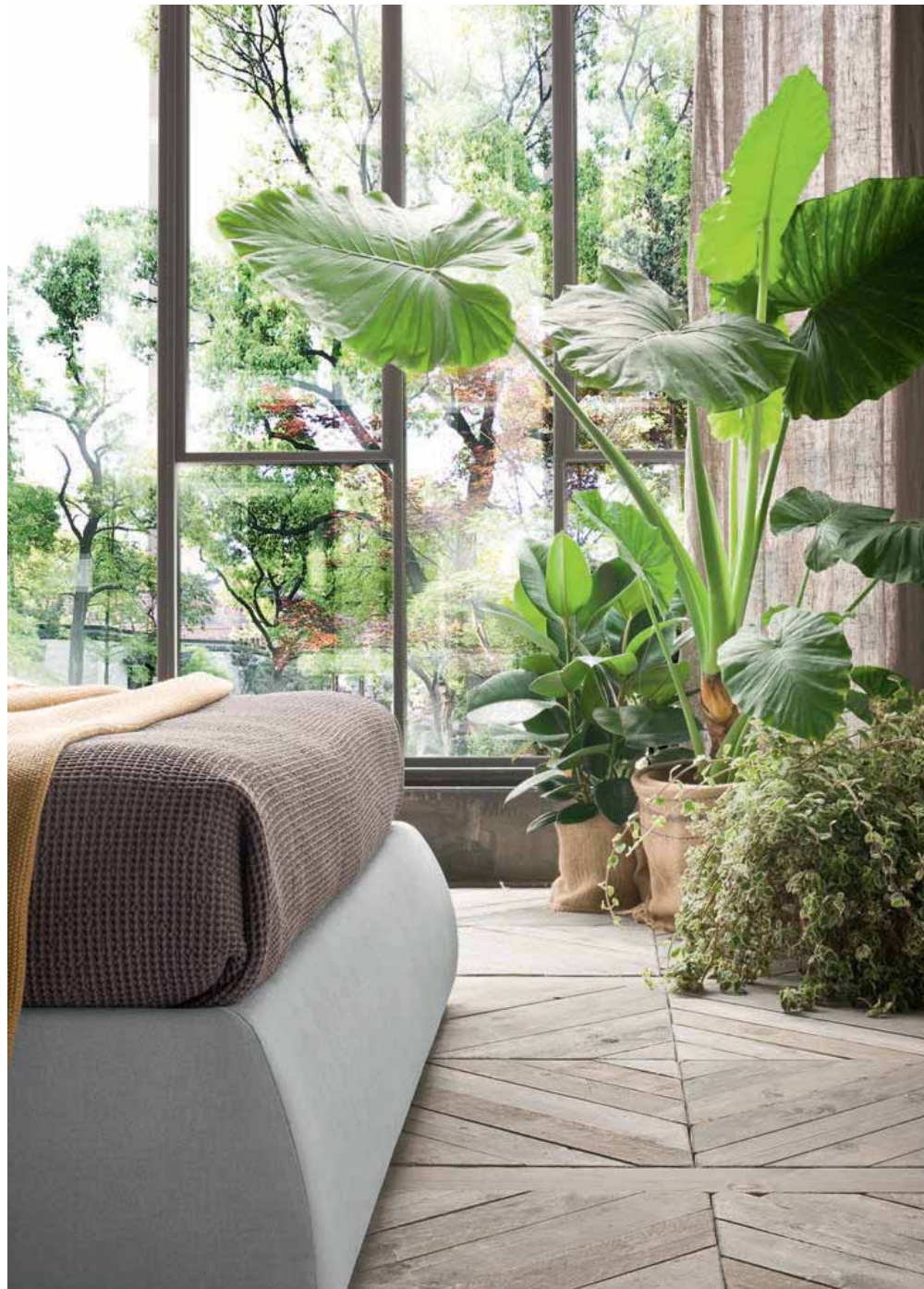

Libero, morbido, naturale,  
scomposto, istintivo, senza  
geometrie e rigide simmetrie:  
questo è Lenny.

Lenny is freely designed, soft,  
natural, disarranged, without  
a hint of geometry or rigid  
symmetry.

Libre, moelleux, naturel,  
décomposé, instinctif, sans  
formes géométriques et  
symétries rigoureuses: voici  
Lenny.

Unbeschwert, weich,  
natürlich, lässig, instinktiv,  
ohne Geometrien und starre  
Symmetrien: das ist Lenny.

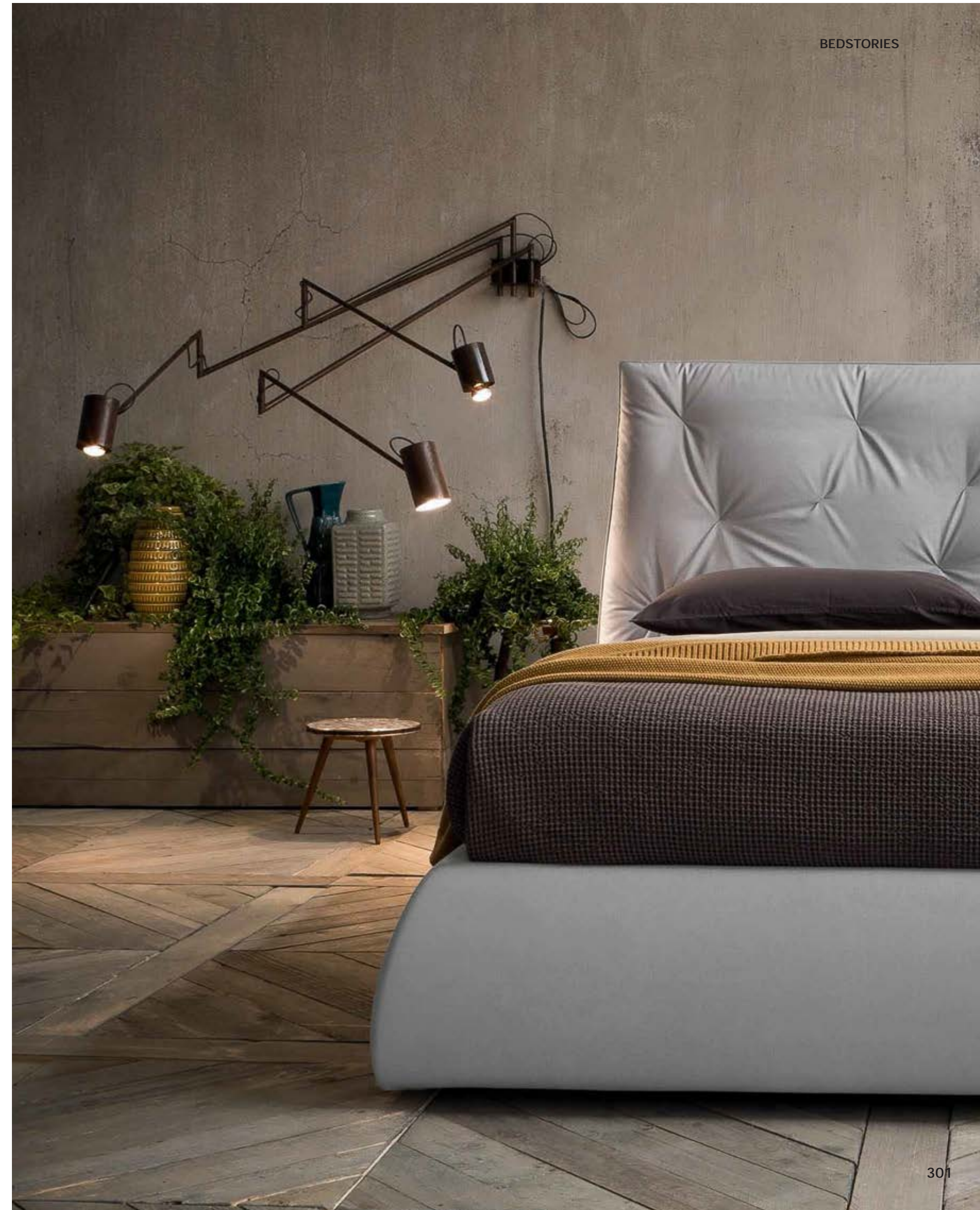







COLLECTION



La testiera si allarga alla base e "contiene" il letto. Anche il giroletto si allarga verso il basso ma con una morbida evidente curva, che lo ancora al pavimento.

The headboard's base widens and "contains" the bed. Also the bed frame widens downwards but with a soft and evident curve, that anchors it to the floor.

La tête de lit s'élargit à la base et "contient" le lit. Le cadre de lit aussi s'élargit vers le bas avec une courbure à la fois souple et marquée, qui le fixe au sol.

Das Kopfteil wird am Fußende breiter und „enthält“ das Bett. Der Bettrahmen verbreitert sich ebenfalls nach unten, jedoch mit einer weichen Kurve, die ihn am Boden verankert.

# Lenny

COMPLETAMENTE SFODERABILE / COMPLETELY REMOVABLE FABRIC / COMPLÈTEMENT DÉHOUSSABLE / VOLLSTÄNDIG ABZIEHBAR

**MASSELLI** in legno di abete e/o scatolati in multistrato di legno di pioppo.  
**PANNELLI** da 18/25 mm in particelle di legno di pioppo in classe E1 a bassa emissione di formaldeide e fibra di legno naturale.  
**ESPANSI** di poliuretano indeformabile a portanza differenziata, densità da 18 kg/mc a 40 kg/mc.  
**PRIMO RIVESTIMENTO** in espanso di poliestere accoppiato a caldo a vellutino aggrappante in poliestere e/o ovatta di poliestere al 100% da 200gr.  
**PANNELLI FONDO** contenitore da 12-14 mm in particelle di legno di pioppo in classe E1.

**FORGINGS** fir wood, and/or boxed in poplar plywood.  
**PANELS** 18/25 mm in poplar wood particles class E1 low formaldehyde emission and natural wood fiber.  
**POLYURETHANE FOAM** crushproof, of different capacity, density from 18 kg/mc to 40 kg/mc.  
**FIRST COATING** hot bonded polyester foam, velvet adhesion in polyester and/or 100% polyester wool, 200gr.  
**CONTAINER BOTTOM** panels 12-14 mm in poplar wood particles class E1.

**TIGE** en pin et/ou boitiers en multicouche en bois de peuplier  
**PANNEAUX** de 18/25 mm en particules de bois de peuplier classe E1 à faible émission de formaldéhyde et fibre de bois naturelle.  
**POLYURÉTHANE EXPANSÉ** indéformable à portée différenciée, densité de 18kg/m<sup>3</sup> à 40kg/m<sup>3</sup>.  
**PREMIER REVÊTEMENT** en polyester expansé accouplé à chaud à un velours accrochant en polyester et/ou ouate de polyester à 100% de 200g.  
**PANNEAUX DE FOND COFFRE** rangement de 12-14mm en particules de bois de peuplier classe E1

**MASSIVES** Tannenholz und/oder Blöcke aus Pappelmeerschholz.  
**SPANPLATTEN** aus Pappelholz mit 18/25 mm Schichtdicke der Klasse E1, geringer Formaldehydabgabe und natürlichen Holzfasern.  
**POLYURETHANSCHAUM**, nicht verformbar und mit differenzierter Tragfähigkeit, Dichten von 18 kg/m<sup>3</sup> bis 40 kg/m<sup>3</sup>.  
**ERSTER ÜBERZUG** aus Polyesterschaum, der auf Polyester-Samt und/oder 100% Polyesterwatte (zu 200 g) heiß aufkaschiert wurde.  
**BODENPLATTEN** des Bettkastens aus 12-14 mm starken Spanplatten aus Pappelholz der Klasse E1.



## RING ROUND

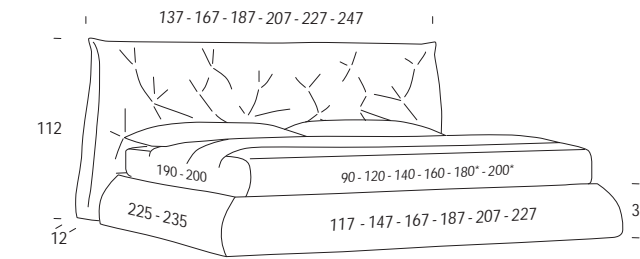

\* Rete L. 180 e L. 200 cm solo profondità 200 cm / Support W. 180 and W. 200 cm only D 200 cm / Sommier L. 180 et L. 200 cm uniquement en profondeur 200 cm / Attenrost B. 180 und B. 200 cm nur mit Tiefe 200 cm

Standard **BASIC H 3**

Pag 545

Optional **LUX H 3**

Pag 545



Wengé / Wengé  
/ Wengé / Wengé



Nero / Black  
/ Noir / Schwarz



Wengé / Wengé  
/ Wengé / Wengé



Nero / Black  
/ Noir / Schwarz



Argento / Silver  
/ Argent / Silber



Bianco / White  
/ Blanc / Weiß



Cromo / Chrome  
/ Chrome / Chrom



Bianco / White  
/ Blanc / Weiß

## Optional Pag 550

Meccanica / Mechanism  
/ Mécanique / Mechanisch

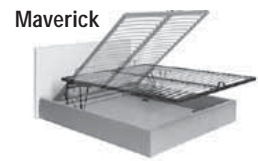
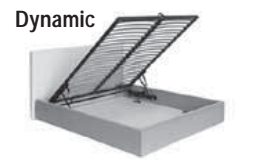

Pag 545

## Optional

Rete / Support / Sommier / Lattenrost Pag 548

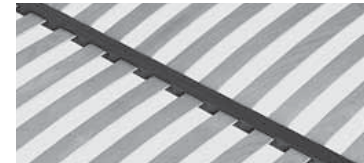

**Armony**  
(Standard)

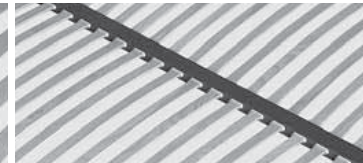

**Thai**  
46 doghe  
46 slats  
46 attes  
46 Leisten

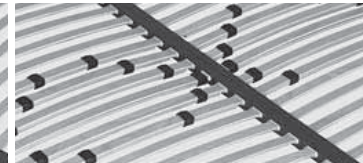

**Energy**  
Non applicabile a rete da 120 cm  
Not applicable to 120 cm support  
Non applicable au sommier de 120 cm  
Gilt nicht für Lattenrost zu 120 cm

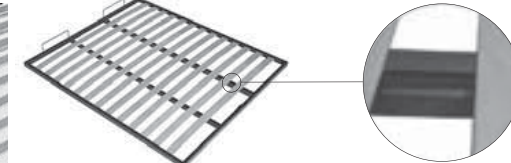

**Doppio Flip**  
Solo 140/160x190/200 - 180x200  
Only 140/160x190/200 - 180x200  
Uniquement 140/160x190/200 - 180x200  
Nur 140/160x190/200 - 180x200

Pag 552



**Sacco contenitore multiuso**  
Multipurpose storage bag  
Sac coffre de rangement multi usage  
Mehrzweck-Aufbewahrungstasche

Pag 553



**Tessuto coprirete traspirante antipolvere**  
Support cover fabric breathable and dustproof  
Tissu couvre-sommier transpirant anti-poussière  
Atmungsaktives, vor Staub schützendes Gewebe

Pag 557



**Regolatore altezza rete solo per reti in appoggio**  
Support height adjuster only for resting frames  
Réglage hauteur sommier uniquement pour sommiers à poser  
Lattenrost-Höhenverstellung nur für aufliegende Lattenroste

Pag 556



**Clean Up System**

# Karl



L'eleganza del design squadrato e monocromo, unita alla verve di un capitonné inedito arricchito dai bottoni multicolor nella tonalità pastello: Karl è il letto creato per tutti coloro che amano uno stile classico e semplice, ma con una punta di brio.

The elegance of the square, monochrome design combined with highly original tufting embellished with multicolour buttons in pastel shades. The Karl bed has been created for those who love classic yet simple style, with a touch of verve.

L'élégance du design carré et monochrome, combinée avec la verve d'un capitonné original enrichi avec des boutons multicolore dans des nuances pastel: Karl est le lit créé pour tous ceux qui aiment un style simple et classique avec une touche de verve.

Die Eleganz des quadratischen und einfarbigen Designs, kombiniert mit dem Schwung einer originellen Capitoné-Verarbeitung, die durch mehrfarbige Knöpfe in Pastelltönen bereichert wird: Karl ist das Bett für alle, die einen klassischen und schlichten Stil lieben, aber mit einem Touch Dynamik.





TIMELESS COLLECTION



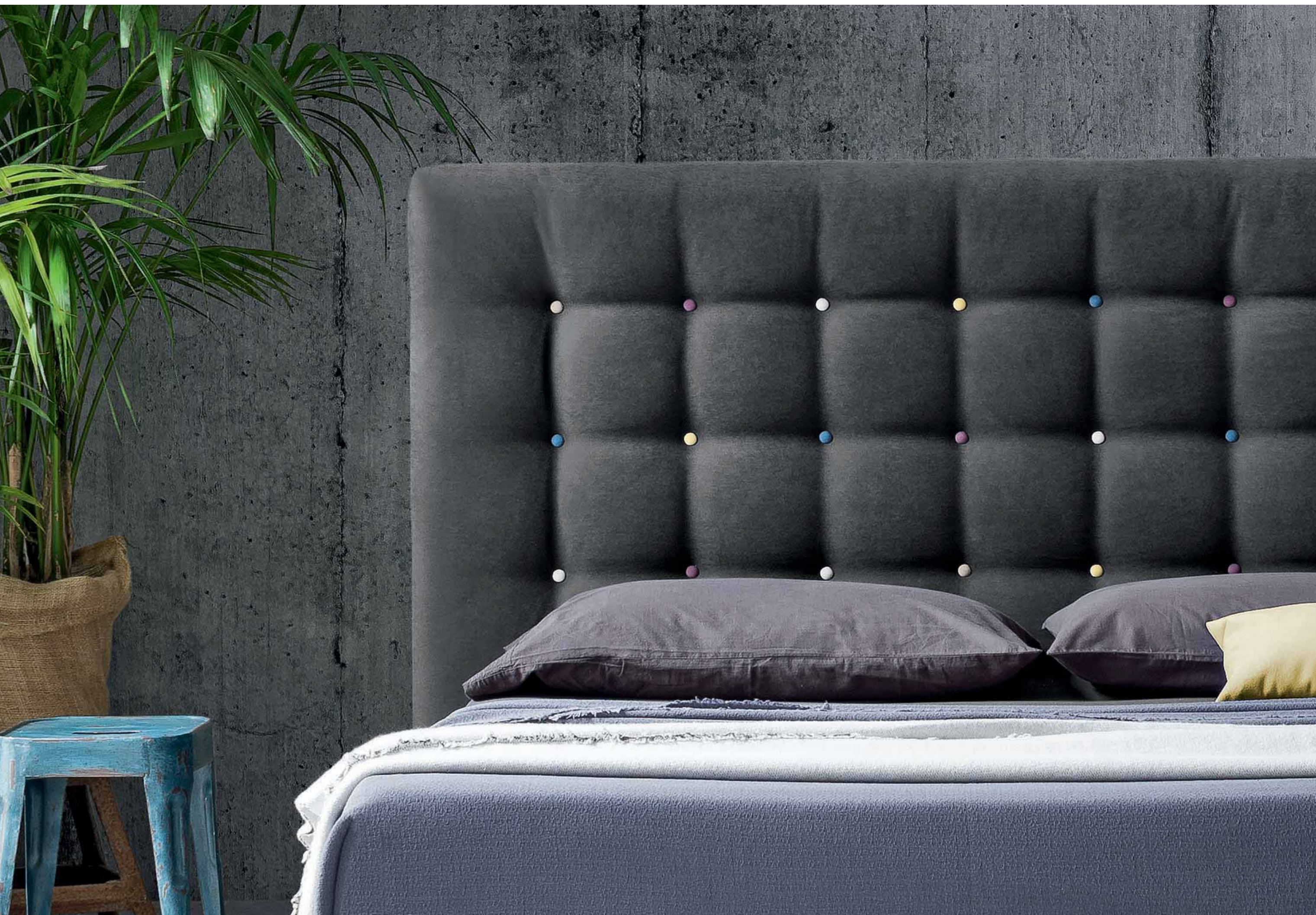

I bottoni possono essere in tinta unita come il tessuto o a contrasto, multicolor (n.b. predefinito azienda), o swarovski bianco o nero.

Buttons can be in the same color as the fabric or in contrast, or multicolor (company-defined), or white or black swarovski.

Les boutons peuvent être de couleur unie, de la même couleur du tissu, ou en contraste, ou encore multicolor (nb. défini par le fabricant), ou swarovski blanc ou noir.

Die Knöpfe können einfarbig wie der Stoff oder kontrastierend, mehrfarbig gewählt werden (Standardversion des Unternehmens) oder aus schwarzen oder weißen Swarovskis sein.

# Karl

COMPLETAMENTE SFODERABILE / COMPLETELY REMOVABLE FABRIC / COMPLÈTEMENT DÉHOUSSABLE / VOLLSTÄNDIG ABZIEHBAR

**MASSELLI** in legno di abete e/o scatolati in multistrato di legno di pioppo.  
**PANNELLI** da 18/25 mm in particelle di legno di pioppo in classe E1 a bassa emissione di formaldeide e fibra di legno naturale.  
**ESPANSI** di poliuretano indeformabile a portanza differenziata, densità da 18 kg/mc a 40 kg/mc.  
**PRIMO RIVESTIMENTO** in espanso di poliestere accoppiato a caldo a vellutino aggrappante in poliestere e/o ovatta di poliestere al 100% da 200gr.  
**PANNELLI FONDO** contenitore da 12-14 mm in particelle di legno di pioppo in classe E1.

**FORGINGS** fir wood, and/or boxed in poplar plywood. **PANELS** 18/25 mm in poplar wood particles class E1 low formaldehyde emission and natural wood fiber.  
**POLYURETHANE FOAM**, crushproof, of different capacity, density from 18 kg/mc to 40 kg/mc.  
**FIRST COATING** hot bonded polyester foam, velvet adhesion in polyester and/or 100% polyester wool, 200gr.  
**CONTAINER BOTTOM** panels 12-14 mm in poplar wood particles class E1.

**TIGE** en pin et/ou boitiers en multicouche en bois de peuplier. **PANNEAUX** de 18/25 mm en particules de bois de peuplier classe E1 à faible émission de formaldéhyde et fibre de bois naturelle.  
**POLYURÉTHANE EXPANSÉ** indéformable à portée différenciée, densité de 18kg/m<sup>3</sup> à 40kg/m<sup>3</sup>.  
**PREMIER REVÊTEMENT** en polyester expansé accouplé à chaud à un velours accrochant en polyester et/ou ouate de polyester à 100% de 200g.  
**PANNEAUX DE FOND COFFRE** coffre rangement de 12-14mm en particules de bois de peuplier classe E1.

**MASSIVES** Tannenholz und/oder Blöcke aus Pappelmehrschichtholz. **SPANPLATTEN** aus Pappelholz mit 18/25 mm Schichtdicke der Klasse E1, geringer Formaldehydabgabe und natürlichen Holzfasern.  
**POLYURETHANSCHAUM**, nicht verformbar und mit differenzierter Tragfähigkeit, Dichten von 18 kg/m<sup>3</sup> bis 40 kg/m<sup>3</sup>.  
**ERSTER ÜBERZUG** aus Polyesterschaum, der auf Polyester-Samt und/oder 100% Polyesterwatte (zu 200 g) heiß aufkaschiert wurde.  
**BODENPLATTEN** des Bettkastens aus 12-14 mm starken Spanplatten aus Pappelholz der Klasse E1.



**Bottoni in tinta o a contrasto oppure Swarovski bianco o nero.**  
 Matching colour, contrasting or black or white Swarovski.  
 Boutons en teinte ou en contraste ou Swarovski blanc ou noir.  
 Knöpfe in der gleichen Farbe oder Swarovskis in Weiß oder Schwarz.

## RING SMART

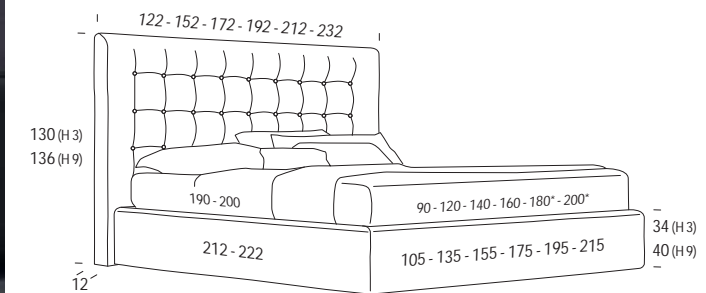

\* Rete L. 180 e L. 200 cm solo profondità 200 cm / Support W. 180 and W. 200 cm only D 200 cm  
 / Sommier L. 180 et L. 200 cm uniquement en profondeur 200 cm / Attenrost B. 180 und B. 200 cm nur mit Tiefe 200 cm

## Optional Pag 550

**Meccanica / Mechanism**  
 / Mécanique / Mechanisch

**Dynamic**



**Maverick**

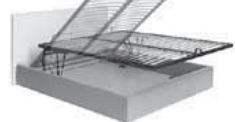

## Optional

Rete / Support / Sommier / Lattenrost Pag 548

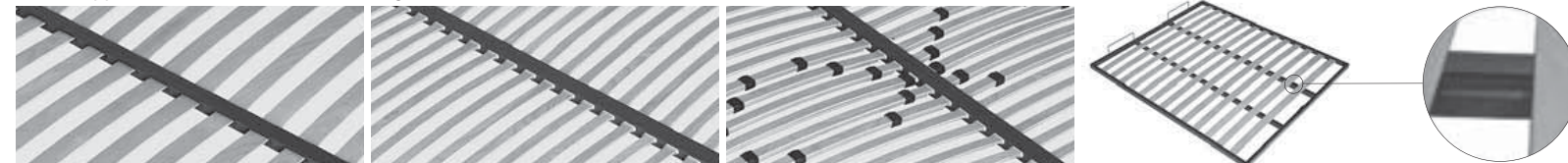

**Armony**  
 (Standard)

**Thai**  
 46 doghe  
 46 slats  
 46 attes  
 46 Leisten

**Energy**  
 Non applicabile a rete da 120 cm  
 Not applicable to 120 cm support  
 Non applicable au sommier de 120 cm  
 Gilt nicht für Lattenrost zu 120 cm

**Doppio Flip**  
 Solo 140/160x190/200 - 180x200  
 Only 140/160x190/200 - 180x200  
 Uniquement 140/160x190/200 - 180x200  
 Nur 140/160x190/200 - 180x200

Pag 552



**Sacco contenitore multiuso**  
 Multipurpose storage bag  
 Sac coffre de rangement multi usage  
 Mehrzweck-Aufbewahrungstasche

Pag 553



**Tessuto coprirete traspirante antipolvere**  
 Support cover fabric breathable and dustproof  
 Tissu couvre-sommier transpirant anti-poussière  
 Atmungsaktives, vor Staub schützendes Gewebe

Pag 557



**Regolatore altezza rete solo per reti in appoggio**  
 Support height adjuster only for resting frames  
 Réglage hauteur sommier uniquement pour sommiers à poser  
 Lattenrost-Höhenverstellung nur für aufliegende Lattenroste

Pag 556



**Clean Up System**

Standard **BASIC H 3**

Pag 545



Wengé / Wengé  
 / Wengé / Wengé



Nero / Black  
 / Noir / Schwarz

Optional **LUX H 3**

Pag 545



Wengé / Wengé  
 / Wengé / Wengé



Nero / Black  
 / Noir / Schwarz

Optional **VISUAL H 9**

Pag 545



Wengé / Wengé  
 / Wengé / Wengé



Nero / Black  
 / Noir / Schwarz



Argento / Silver  
 / Argent / Silber



Bianco / White  
 / Blanc / Weiß



Cromo / Chrome  
 / Chrome / Chrom



Bianco / White  
 / Blanc / Weiß



Argento / Silver  
 / Argent / Silber



Bianco / White  
 / Blanc / Weiß



# Hamilton



Stile contemporaneo, ma con un tocco di classicità che lo rende ancora più speciale: Hamilton è caratterizzato da una testiera grande e morbida con effetto capitonné che evidenzia lo spessore dell'imbottitura.

Contemporary in style yet with a hint of classicism that makes it even more special. Hamilton sports a large, soft headboard featuring tufting effect, which emphasises the thickness of the padding.

Décoration contemporaine, mais avec une touche d'élégance classique qui le rend encore plus spécial: Hamilton se caractérise par une tête de lit grande et moelleuse avec effet capitonné qui met en évidence l'épaisseur du rembourrage.

Ein zeitgemäßer Stil, aber mit einem klassischen Touch, der dem Bett eine besondere Note verleiht: Hamilton hat ein großes, weiches Kopfteil mit Capitonné-Effekt, der die Schichtdicke der Polsterung hervorhebt.





LESS COLLECT

BEDSTORIES





Il giroletto è segnato dalla modularità delle doppie cuciture verticali. La lavorazione della testiera è morbida e profonda, ed evidenzia la particolare cucitura. Il gioco dei vuoti e dei pieni ne enfatizza lo spessore.

The bed frame is marked by the modularity of double vertical seams. The processing of the headboard is soft and deep, highlighting the particular work. The game of empty and filled spaces emphasizes its thickness.

Le tour de lit est caractérisé par la modularité des doubles coutures verticales. La réalisation de la tête de lit moelleuse et profonde, met en évidence la réalisation particulière. Le jeu des vides et des pleins amplifie l'épaisseur.

Der Bettrahmen zeichnet sich durch die Modularität der doppelten vertikalen Nähte aus. Die Verarbeitung des Kopfteils ist weich und tief und hebt die besondere Absteppung hervor. Das Wechselspiel zwischen voll und leer unterstreicht die Schichtdicke der Polsterung.



# Hamilton

COMPLETAMENTE SFODERABILE / COMPLETELY REMOVABLE FABRIC / COMPLÈTEMENT DÉHOUSSABLE / VOLLSTÄNDIG ABZIEHBAR

**MASSELLI** in legno di abete e/o scatolati in multistrato di legno di pioppo.

**PANNELLI** da 18/25 mm in particelle di legno di pioppo in classe E1 a bassa emissione di formaldeide e fibra di legno naturale.

**ESPANSI** di poliuretano indeformabile a portanza differenziata, densità da 18 kg/mc a 40 kg/mc.

**PRIMO RIVESTIMENTO** in espanso di poliestere accoppiato a caldo a vellutino aggrappante in poliestere e/o ovatta di poliestere al 100% da 200gr.

**PANNELLI FONDO** contenitore da 12-14 mm in particelle di legno di pioppo in classe E1.

**FORGINGS** fir wood, and/or boxed in poplar plywood.

**PANELS** 18/25 mm in poplar wood particles class E1 low formaldehyde emission and natural wood fiber.

**POLYURETHANE FOAM** crushproof, of different capacity, density from 18 kg/mc to 40 kg/mc.

**FIRST COATING** hot bonded polyester foam, velvet adhesion in polyester and/or 100% polyester wool, 200gr.

**CONTAINER BOTTOM** panels 12-14 mm in poplar wood particles class E1.

**TIGE** en pin et/ou boitiers en multicouche en bois de peuplier.

**PANNEAUX** de 18/25 mm en particules de bois de peuplier classe E1 à faible émission de formaldéhyde et fibre de bois naturelle.

**POLYURÉTHANE EXPANSÉ** indéformable à portée différenciée, densité de 18kg/m<sup>3</sup> à 40kg/m<sup>3</sup>.

**PREMIER REVÊTEMENT** en polyester expansé accouplé à chaud à un velours accrochant en polyester et/ou ouate de polyester à 100% de 200g.

**PANNEAUX DE FOND COFFRE** rangement de 12-14mm en particules de bois de peuplier classe E1.

**MASSIVES** Tannenholz und/oder Blöcke aus Pappelmehrschichtholz.

**SPANPLATTEN** aus Pappelholz mit 18/25 mm Schichtdicke der Klasse E1, geringer Formaldehydabgabe und natürlichen Holzfasern.

**POLYURETHANSCHAUM** mit Dichten von 18 kg/m<sup>3</sup> bis 40 kg/m<sup>3</sup>. Kissen mit Watte zu 300 g überzogen.

**ERSTER ÜBERZUG** aus Polyesterschaum, der auf Polyester-Samt und/oder 100% Polyesterwatte (zu 200 g) heiß aufkaschiert wurde.

**BODENPLATTEN** des Bettkastens aus 12-14 mm starken Spanplatten aus Pappelholz der Klasse E1.



## Optional

Rete / Support / Sommier / Lattenrost Pag 548

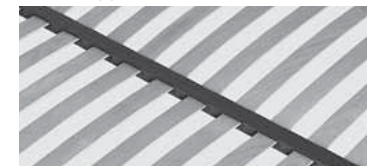

**Armony**  
(Standard)

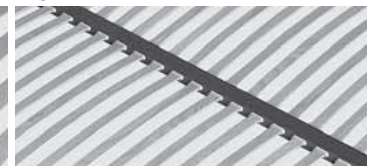

**Thai**  
46 doghe  
46 slats  
46 attes  
46 Leisten

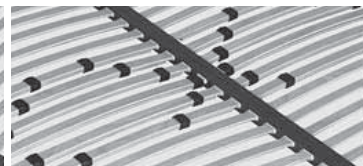

**Energy**  
Non applicabile a rete da 120 cm  
Not applicable to 120 cm support  
Non applicable au sommier de 120 cm  
Gilt nicht für Lattenrost zu 120 cm

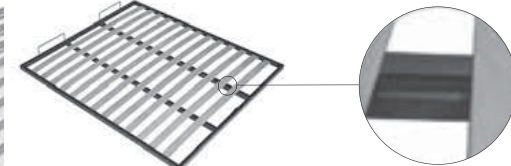

**Doppio Flip**  
Solo 140/160x190/200 - 180x200  
Only 140/160x190/200 - 180x200  
Uniquement 140/160x190/200 - 180x200  
Nur 140/160x190/200 - 180x200

Pag 552



**Sacco contenitore multiuso**  
Multipurpose storage bag  
Sac coffre de rangement multi usage  
Mehrzweck-Aufbewahrungstasche

Pag 553



**Tessuto coprirete traspirante antipolvere**  
Support cover fabric breathable and dustproof  
Tissu couvre-sommier transpirant anti-poussière  
Atmungsaktives, vor Staub schützendes Gewebe

Pag 557



**Regolatore altezza rete solo per reti in appoggio**  
Support height adjuster only for resting frames  
Réglage hauteur sommier uniquement pour sommiers à poser  
Lattenrost-Höhenverstellung nur für aufliegende Lattenroste

Pag 556



**Clean Up System**

## RELAX SYSTEM

### RING NEO



### RING SMART

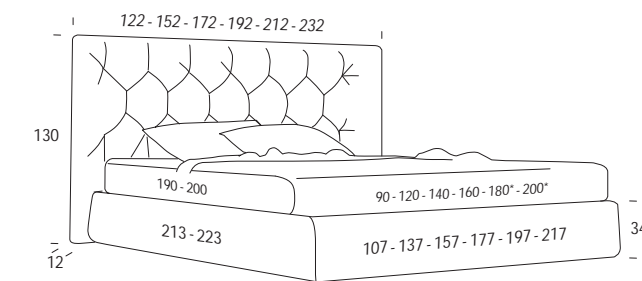
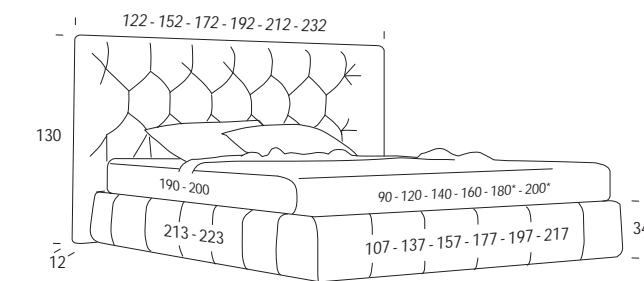

## Optional Pag 550

Meccanica / Mechanism  
/ Mécanique / Mechanisch

Dynamic



Maverick



\* Rete L. 180 e L. 200 cm solo profondità 200 cm / Support W. 180 and W. 200 cm only D 200 cm  
/ Sommier L. 180 et L. 200 cm uniquement en profondeur 200 cm / Attenrost B. 180 und B. 200 cm nur mit Tiefe 200 cm

Standard BASIC H 3

Pag 545

Optional LUX H 3

Pag 545



Wengé / Wengé  
/ Wengé / Wengé



Nero / Black  
/ Noir / Schwarz



Wengé / Wengé  
/ Wengé / Wengé



Nero / Black  
/ Noir / Schwarz



Argento / Silver  
/ Argent / Silber



Bianco / White  
/ Blanc / Weiß



Cromo / Chrome  
/ Chrome / Chrom



Bianco / White  
/ Blanc / Weiß

# Dennis

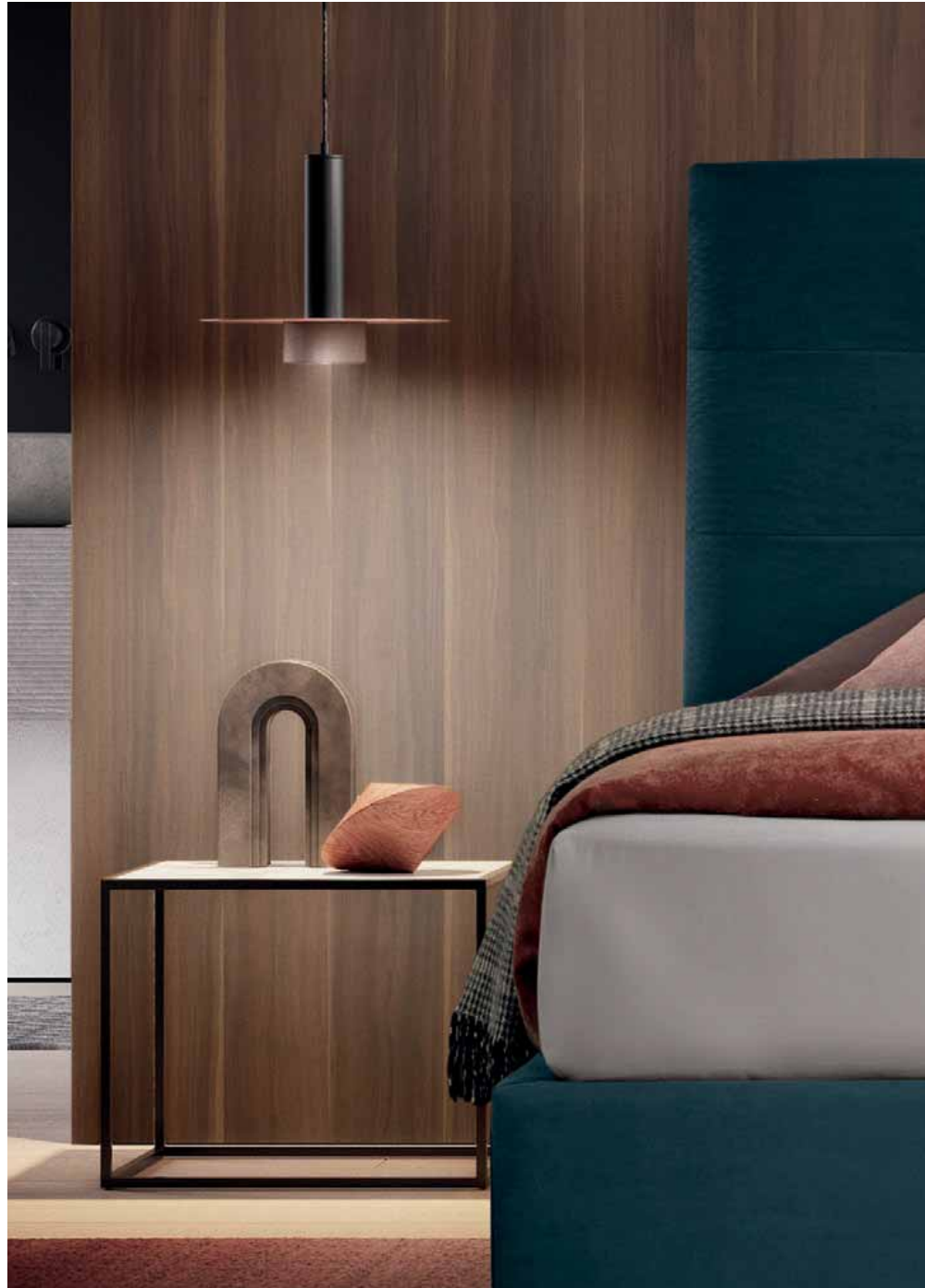

Una testiera importante dalla geometria decisa: ecco Dennis, forte personalità, carattere autorevole e un'impronta prestigiosa.

An imposing headboard sporting a bold geometric design: Dennis has a strong personality, an authoritative character and an air of prestige.

Une tête de lit importante ayant une géométrie nette: voilà Dennis, forte personnalité, immense caractère et une empreinte prestigieuse.

Ein imposantes Kopfteil mit einer entschlossenen Geometrie: das ist Dennis, eine starke Persönlichkeit, ein bestimmender Charakter mit einer edlen Note.

BEDSTORIES







Le due diverse versioni di giroletto disponibili sottolineano o alleggeriscono l'importanza e la geometria della testiera.

The two different versions of the bed frame available emphasize or lighten the importance and the geometry of the headboard.

Les deux versions de tour de lit disponibles soulignent ou allègent l'importance et la géométrie de la tête de lit.

Die zwei verschiedenen Ausführungen des Bettrahmens betonen oder mildern die Bedeutung und Geometrie des Kopfteils ab.







# Dennis

COMPLETAMENTE SFODERABILE / COMPLETELY REMOVABLE FABRIC / COMPLÈTEMENT DÉHOUSSABLE / VOLLSTÄNDIG ABZIEHBAR

**MASSELLI** in legno di abete e/o scatolati in multistrato di legno di pioppo.

**PANNELLI** da 18/25 mm in particelle di legno di pioppo in classe E1 a bassa emissione di formaldeide e fibra di legno naturale.

**ESPANSI** di poliuretano indeformabile a portanza differenziata, densità da 18 kg/mc a 40 kg/mc.

**PRIMO RIVESTIMENTO** in espanso di poliestere accoppiato a caldo a vellutino aggrappante in poliestere e/o ovatta di poliestere al 100% da 200gr.

**PANNELLI FONDO** contenitore da 12-14 mm in particelle di legno di pioppo in classe E1.

**FORGINGS** fir wood, and/or boxed in poplar plywood.

**PANELS** 18/25 mm in poplar wood particles class E1 low formaldehyde emission and natural wood fiber.

**POLYURETHANE FOAM** crushproof, of different capacity, density from 18 kg/mc to 40 kg/mc.

**FIRST COATING** hot bonded polyester foam, velvet adhesion in polyester and/or 100% polyester wool, 200gr.

**CONTAINER BOTTOM** panels 12-14 mm in poplar wood particles class E1.

**TIGE** en pin et/ou boitiers en multicouche en bois de peuplier.

**PANNEAUX** de 18/25 mm en particules de bois de peuplier classe E1 à faible émission de formaldéhyde et fibre de bois naturelle.

**POLYURÉTHANE EXPANSÉ** indéformable à portée différenciée, densité de 18kg/m<sup>3</sup> à 40kg/m<sup>3</sup>.

**PREMIER REVÊTEMENT** en polyester expansé accouplé à chaud à un velours accrochant en polyester et/ou ouate de polyester à 100% de 200g.

**PANNEAUX DE FOND COFFRE** rangement de 12-14mm en particules de bois de peuplier classe E

**MASSIVES** Tannenholz und/oder Blöcke aus Pappelmehrschichtholz.

**SPANPLATTEN** aus Pappelholz mit 18/25 mm Schichtdicke der Klasse E1, geringer Formaldehydabgabe und natürlichen Holzfasern.

**POLYURETHANSCHAUM**, nicht verformbar und mit differenzierter Tragfähigkeit, Dichten von 18 kg/m<sup>3</sup> bis 40 kg/m<sup>3</sup>.

**ERSTER ÜBERZUG** aus Polyesterschaum, der auf Polyester-Samt und/oder 100% Polyesterwatte (zu 200 g) heiß aufkaschiert wurde.

**BODENPLATTEN** des Bettkastens aus 12-14 mm starken Spanplatten aus Pappelholz der Klasse E1.

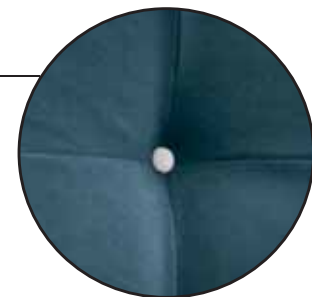

Bottoni in tinta unita o a contrasto o Swarovski bianco o nero.  
/ Buttons in the same color as the fabric, or contrasting, or mixed colors or black or white Swarovski.  
/ Boutons couleur tissu ou en contraste ou mélange de couleur ou Swarovski blanc ou noir.  
/ Knöpfe in der gleichen Farbe oder in einer Kontrastfarbe oder mehrfarbig oder Swarovskis in Weiß oder Schwarz.

## Optional

Rete / Support / Sommier / Lattenrost Pag 548

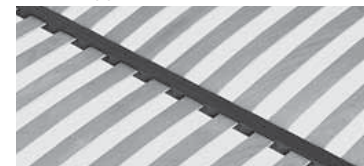

**Armony**  
(Standard)

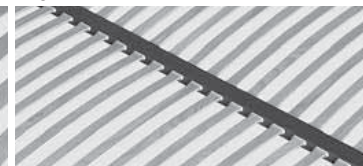

**Thai**  
46 doghe  
46 slats  
46 attes  
46 Leisten

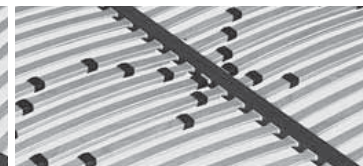

**Energy**  
Non applicabile a rete da 120 cm  
Not applicable to 120 cm support  
Non applicable au sommier de 120 cm  
Gilt nicht für Lattenrost zu 120 cm

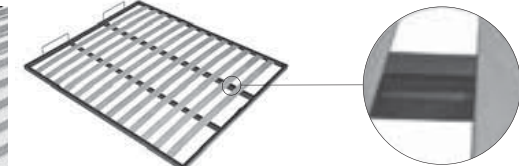

**Doppio Flip**  
Solo 140/160x190/200 - 180x200  
Only 140/160x190/200 - 180x200  
Uniquement 140/160x190/200 - 180x200  
Nur 140/160x190/200 - 180x200

Pag 552



**Sacco contenitore multiuso**  
Multipurpose storage bag  
Sac coffre de rangement multi usage  
Mehrzweck-Aufbewahrungstasche

Pag 553



**Tessuto coprirete traspirante antipolvere**  
Support cover fabric breathable and dustproof  
Tissu couvre-sommier transpirant anti-poussière  
Atmungsaktives, vor Staub schützendes Gewebe

Pag 557



**Regolatore altezza rete solo per reti in appoggio**  
Support height adjuster only for resting frames  
Réglage hauteur sommier uniquement pour sommiers à poser  
Lattenrost-Höhenverstellung nur für aufliegende Lattenroste

Pag 556



**Clean Up System**

## RING SMART

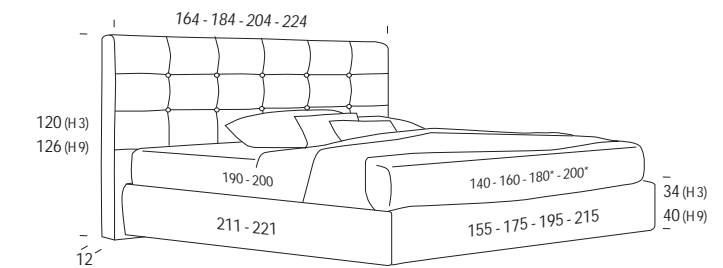

\* Rete L. 180 e L. 200 cm solo profondità 200 cm / Support W. 180 and W. 200 cm only D 200 cm  
/ Sommier L. 180 et L. 200 cm uniquement en profondeur 200 cm / Attenrost B. 180 und B. 200 cm nur mit Tiefe 200 cm

Standard **BASIC H 3**



Wengé / Wengé  
/ Wengé / Wengé

Pag 545



Nero / Black  
/ Noir / Schwarz

Optional **LUX H 3**



Wengé / Wengé  
/ Wengé / Wengé

Pag 545



Nero / Black  
/ Noir / Schwarz

Optional **VISUAL H 9**



Wengé / Wengé  
/ Wengé / Wengé

Pag 545



Nero / Black  
/ Noir / Schwarz

## RING YORK

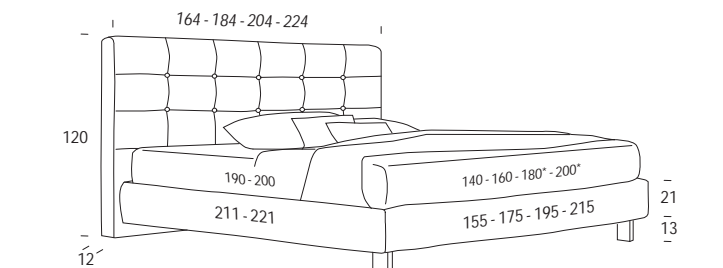

\* Rete L. 180 e L. 200 cm solo profondità 200 cm / Support W. 180 and W. 200 cm only D 200 cm  
/ Sommier L. 180 et L. 200 cm uniquement en profondeur 200 cm / Attenrost B. 180 und B. 200 cm nur mit Tiefe 200 cm

Standard **BLADE H 13**



Satinato / Satin  
/ Satiné / Satiniert

Pag 546



Bronzato / Bronze  
/ Bronze / Bronziert

Optional **TOWER H 13**



Optional **PLEXY H 13**



Pag 546

## Optional Pag 550

Meccanica / Mechanism  
/ Mécanique / Mechanisch

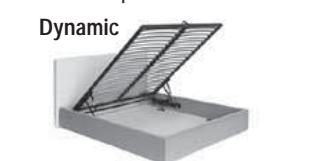

# Adrian



Una cornice a fare da contenitore alla testiera vera e propria: un pannello personalizzabile in tre varianti, Déco, Plissé oppure Imperial. Adrian così cambia completamente il suo stile, diventando esclusivo ad ogni configurazione.

The headboard panel has a frame around it, which is available in three different versions: Déco, Plissé or Imperial. Three exclusive configurations that change Adrian's style completely.

Un cadre qui contient la véritable tête de lit: un panneau personnalisable en trois versions, Déco, Plissé ou Imperial. Ainsi Adrian change complètement son style et devient exclusif en toutes les configurations.

Ein Rahmen, der als Aufnahme für das eigentliche Kopfteil dient: ein Paneel, das in den drei Versionen Déco, Plissé oder Imperial ganz nach Geschmack ausgewählt werden kann. Adrian verändert also seinen Stil und wird mit jeder Konfiguration exklusiver.





## TIMELESS COLLECTION

Una cornice telaio contiene la testiera facilmente sfoderabile. Disponibile in tre diverse versioni: (1) Decó standard (2) Plissé (3) Imperial.

A frame contains the headboard, which is easily removable. Available in three different versions: (1) Standard Decó (2) Plissé (3) Imperial.

Un cadre contient la tête de lit facilement déhoussable. Disponible en trois versions: (1) Decó standard (2) Plissé (3) Imperial.

Der Rahmen dient als Aufnahme des leicht abziehbaren Kopfteils. Ist in drei verschiedenen Versionen erhältlich: (1) Decó standard (2) Plissé (3) Imperial.



1. Decó



2. Plissé



3. Imperial



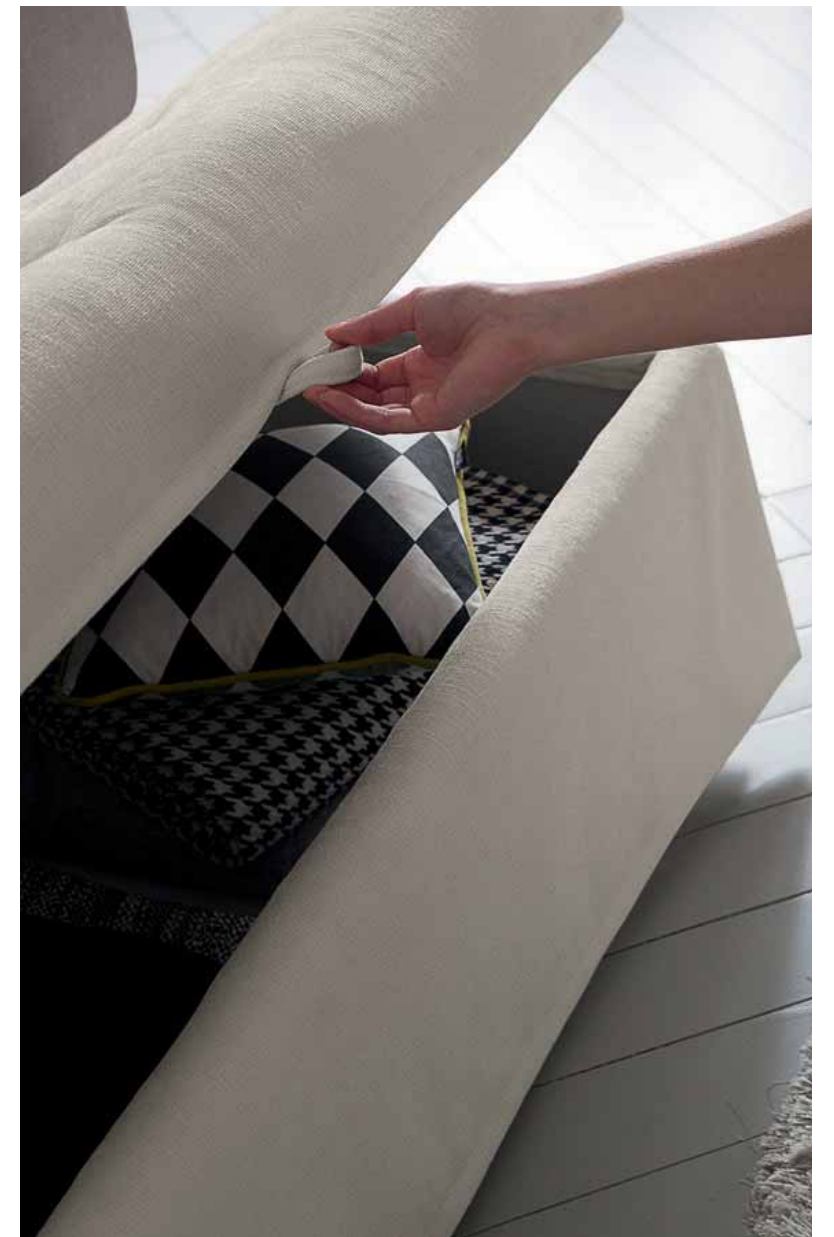

Comodissimo complemento coordinato alla pediera. Una seduta, un piano d'appoggio e un contenitore con apertura servo assistita. Posizionabile ovunque in camera.

Convenient coordinated footboard. A seat, a supporting surface and an container with power assisted opening. It can be placed anywhere in the room.

Pratique entièrement assorti au pied de lit. Une assise, un plan d'appui et un coffre de rangement à ouverture assistée. Peut être placé n'importe où dans la chambre.

Eine sehr praktische Ergänzung zum Fußteil. Eine Sitzgelegenheit, eine Ablagefläche und ein Stauraum mit servounterstützter Öffnung. Kann überall im Raum aufgestellt werden.



La cornice si accompagna allo spessore del giroletto e agli angoli con gonnella a volant per un risultato moderno che non rinuncia al gusto della citazione classica.

The frame is accompanied by the thickness of the bed frame and the corners with the frilled skirt for a modern result that does not renounce classic taste.

Le cadre accompagne l'épaisseur du tour de lit et des angles à jupe à volant pour un résultat moderne qui ne renonce pas au rappel du classique.

Der Rahmen passt sich der Höhe des Bettrahmens und an die Ecken mit dem umlaufenden Volant an, was zu einem modernen Endresultat führt, ohne auf klassische Untertöne zu verzichten.

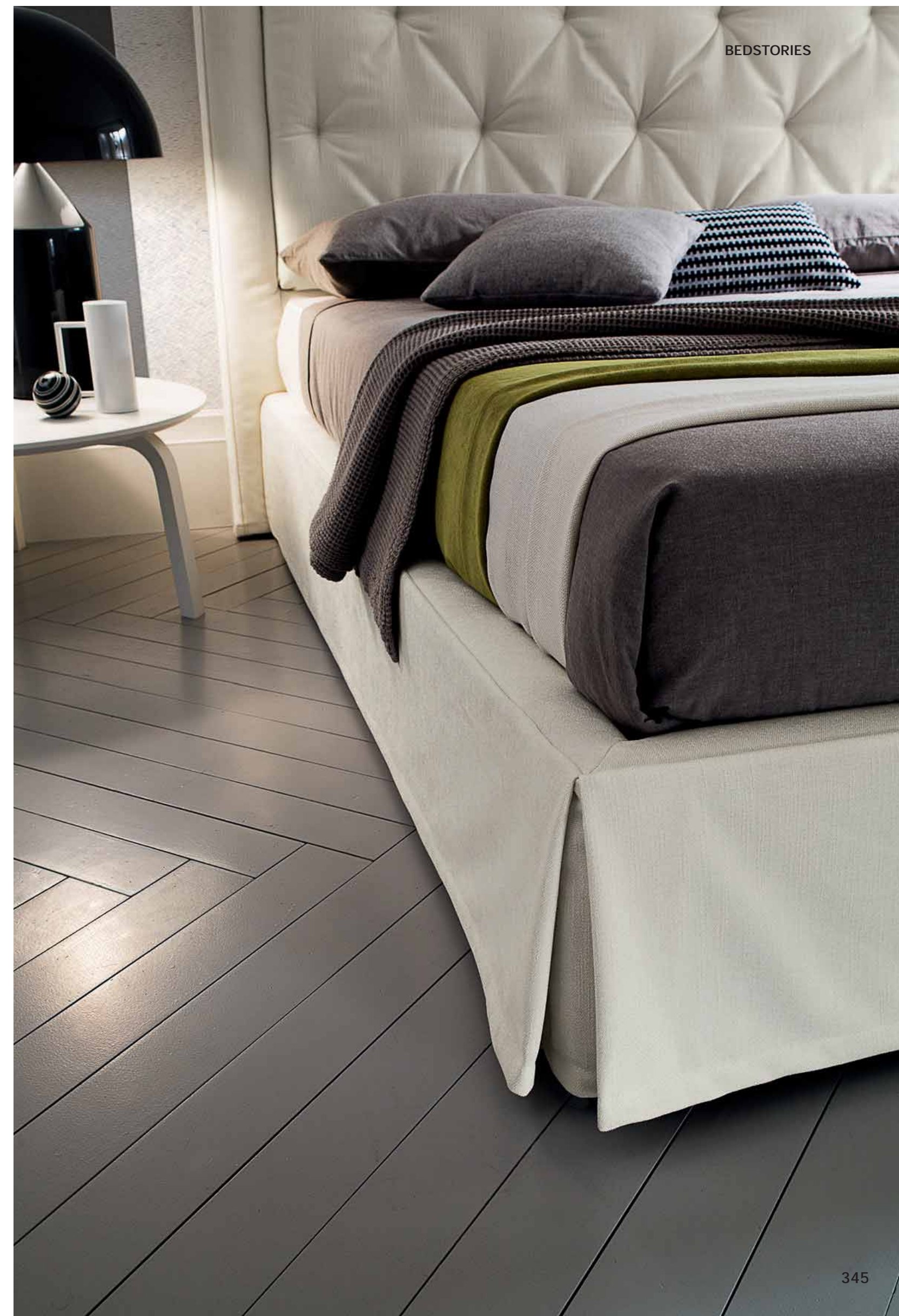

# Adrian

COMPLETAMENTE SFODERABILE / COMPLETELY REMOVABLE FABRIC / COMPLÈTEMENT DÉHOUSSABLE / VOLLSTÄNDIG ABZIEHBAR

**MASSELLI** in legno di abete e/o scatolati in multistrato di legno di pioppo.

**PANNELLI** da 18/25 mm in particelle di legno di pioppo in classe E1 a bassa emissione di formaldeide e fibra di legno naturale.

**ESPANSI** di poliuretano in densità da 18 kg/mc a 40 kg/mc. Cuscini rivestiti in ovatta da 300 gr.

**PRIMO RIVESTIMENTO** in espanso di poliestere accoppiato a caldo a vellutino aggrappante in poliestere e/o ovatta di poliestere al 100% da 200gr.

**PANNELLI FONDO** contenitore da 12-14 mm in particelle di legno di pioppo in classe E1.

**FORGINGS** fir wood, and/or boxed in poplar plywood.

**PANELS** 18/25 mm in poplar wood particles class E1 low formaldehyde emission and natural wood fiber.

**POLYURETHANE FOAM** density from 18 kg/mc to 40 kg/mc. Cushions coated with 300 gr wadding.

**FIRST COATING** hot bonded polyester foam, velvet adhesion in polyester and/or 100% polyester wool, 200gr.

**CONTAINER BOTTOM** panels 12-14 mm in poplar wood particles class E1.

**TIGE** en pin et/ou boitiers en multicouche en bois de peuplier.

**PANNEAUX** de 18/25 mm en particules de bois de peuplier classe E1 à faible émission de formaldéhyde et fibre de bois naturelle.

**POLYURÉTHANE EXPANSÉ** densité de 18kg/m<sup>3</sup> à 40kg/m<sup>3</sup>. Coussin rembourrés avec de la ouate de 300g.

**PREMIER REVÊTEMENT** en polyester expansé accouplé à chaud à un velours accrochant en polyester et/ou ouate de polyester à 100% de 200g.

**PANNEAUX DE FOND COFFRE** rangement de 12-14mm en particules de bois de peuplier classe E1.

**MASSIVES** Tannenholz und/oder Blöcke aus Pappelmehrschichtholz.

**SPANPLATTEN** aus Pappelholz mit 18/25 mm Schichtdicke der Klasse E1, geringer Formaldehydabgabe und natürlichen Holzfasern.

**POLYURETHANSCHAUM** mit Dichten von 18 kg/m<sup>3</sup> bis 40 kg/m<sup>3</sup>. Kissen mit Watte zu 300 g überzogen.

**ERSTER ÜBERZUG** aus Polyesterschaum, der auf Polyester-Samt und/oder 100% Polyesterwatte (zu 200 g) heiß aufkaschiert wurde.

**BODENPLATTEN** des Bettkastens aus 12-14 mm starken Spanplatten aus Pappelholz der Klasse E1.



Decò

Plissé

Imperial

**Pannelli testiera in tutte le finiture / Headboard panels in all finishes / Panneaux tête de lit de toutes les finitions / Die Kopfteilpaneele in allen Ausführungen.**

## RING SMART PLUS



## RING VENICE PLUS



## Optional Pag 550

Meccanica / Mechanism / Mécanique / Mechanisch

Dynamic



Maverick

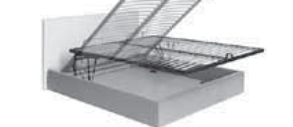

## Optional

Rete / Support / Sommier / Lattenrost Pag 548

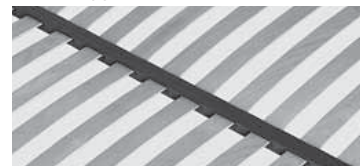

**Armony** (Standard)

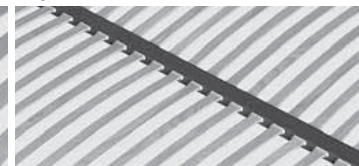

**Thai** 46 doghe  
46 slats  
46 attes  
46 Leisten

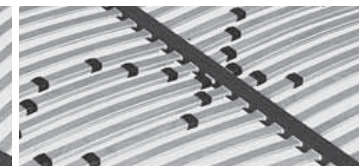

**Energy**  
Non applicabile a rete da 120 cm  
Not applicable to 120 cm support  
Non applicable au sommier de 120 cm  
Gilt nicht für Lattenrost zu 120 cm

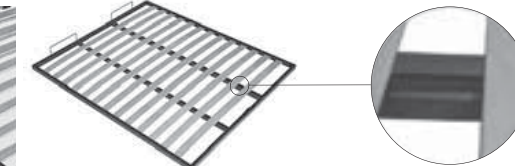

**Doppio Flip**  
Solo 140/160x190/200 - 180x200  
Only 140/160x190/200 - 180x200  
Uniquement 140/160x190/200 - 180x200  
Nur 140/160x190/200 - 180x200

Pag 552



**Sacco contenitore multiuso**  
Multipurpose storage bag  
Sac coffre de rangement multi usage  
Mehrzweck-Aufbewahrungstasche

Pag 553



**Tessuto coprirete traspirante antipolvere**  
Support cover fabric breathable and dustproof  
Tissu couvre-sommier transpirant anti-poussière  
Atmungsaktives, vor Staub schützendes Gewebe

Pag 557



**Regolatore altezza rete solo per reti in appoggio**  
Support height adjuster only for resting frames  
Réglage hauteur sommier uniquement pour sommiers à poser  
Lattenrost-Höhenverstellung nur für aufliegende Lattenroste

Pag 556



**Clean Up System**

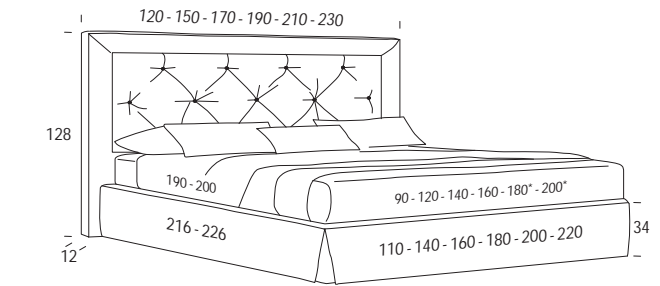
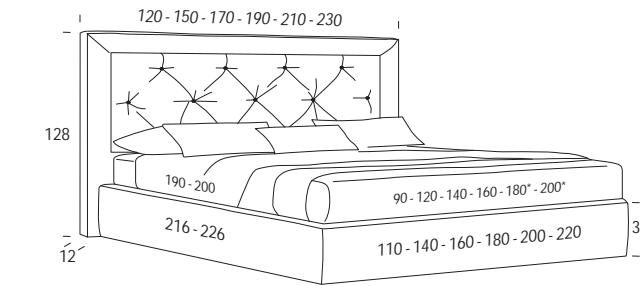

\* Rete L. 180 e L. 200 cm solo profondità 200 cm / Support W. 180 and W. 200 cm only D 200 cm / Sommier L. 180 et L. 200 cm uniquement en profondeur 200 cm / Attenrost B. 180 und B. 200 cm nur mit Tiefe 200 cm

Standard BASIC H 3 Pag 545

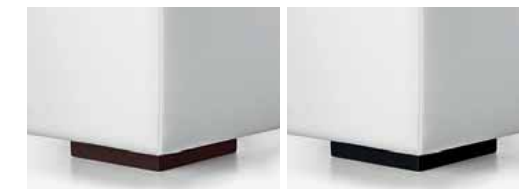

Wengé / Wengé  
/ Wengé / Wengé

Optional LUX H 3 Pag 545



Nero / Black  
/ Noir / Schwarz

Optional LUX H 3 Pag 545



Wengé / Wengé  
/ Wengé / Wengé

Optional LUX H 3 Pag 545



Nero / Black  
/ Noir / Schwarz

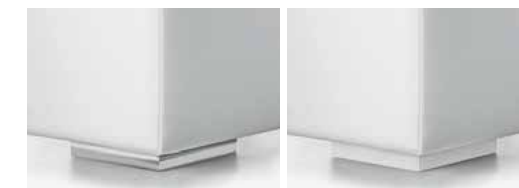

Argento / Silver  
/ Argent / Silber



Bianco / White  
/ Blanc / Weiß



Cromo / Chrome  
/ Chrome / Chrom



Bianco / White  
/ Blanc / Weiß

# Julius



La testiera di Julius è impreziosita da un cordoncino in rilievo che disegna un motivo minimale, ma che dona dinamicità.

The headboard on Julius is embellished with relief piping, which creates a minimalist motif and adds dynamism.

La tête de lit de Julius est embellie par un cordon en relief qui dessine un motif minimal, mais qui donne dynamisme.

Das Kopfteil von Julius besticht durch eine hervorstehende Bordüre, die ein minimalistisches, aber dynamisches Muster bildet.







Doppia possibilità per il ring. La versione più bassa è sollevata da una ricca scelta di piedini, per accentuare il senso di leggerezza.

Double possibility for the ring. The lower and lighter version is raised by a rich choice of feet, to accentuate the sense of lightness.

Double possibilité pour le tour de lit. La version plus basse et légère peut être est soulevée par un grand choix de pieds, pour accentuer le sens de légèreté.

Die Linie der hervorstehenden Bordüre designt, umhüllt und verbindet das Kopfteil. Ein minimalistisches, aber feines handwerkliches Detail.

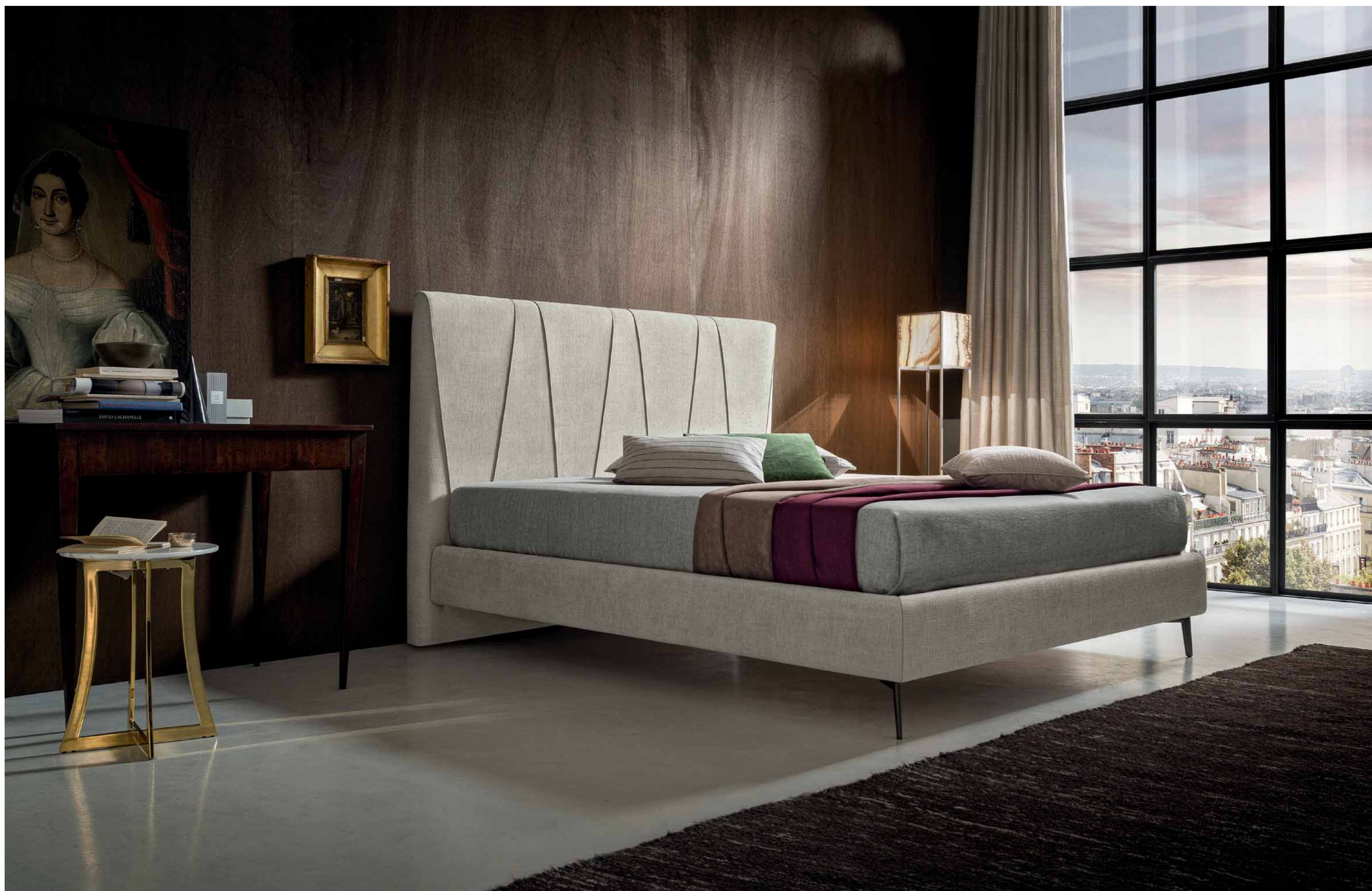



La linea del cordoncino a rilievo disegna, avvolge e lega la testiera. Un particolare sartoriale minimal ma prezioso.

The line of the cord in relief designs, surrounds, and binds the headboard. A minimal but precious sartorial detail.

La ligne du cordon en relief dessine en enveloppe la tête de lit. Un détail de couture minimaliste mais précieux.

Das Bettgestell ist in zwei Ausführungen erhältlich. Für die niedrigere Version stehen zahlreiche Fußmodelle zur Verfügung, die dem Modell einen leichteren Gesamteindruck verleihen.

# Julius

COMPLETAMENTE SFODERABILE / COMPLETELY REMOVABLE FABRIC / COMPLÈTEMENT DÉHOUSSABLE / VOLLSTÄNDIG ABZIEHBAR

**MASSELLI** in legno di abete e/o scatolati in multistrato di legno di pioppo.

**PANNELLI** da 18/25 mm in particelle di legno di pioppo in classe E1 a bassa emissione di formaldeide e fibra di legno naturale.

**ESPANSI** di poliuretano indeformabile a portanza differenziata, densità da 18 kg/mc a 40 kg/mc.

**PRIMO RIVESTIMENTO** in espanso di poliestere accoppiato a caldo a vellutino aggrappante in poliestere e/o ovatta di poliestere al 100% da 200gr.

**PANNELLI FONDO** contenitore da 12-14 mm in particelle di legno di pioppo in classe E1.

**FORGINGS** fir wood, and/or boxed in poplar plywood.

**PANELS** 18/25 mm in poplar wood particles class E1 low formaldehyde emission and natural wood fiber.

**POLYURETHANE FOAM**, crushproof, of different capacity, density from 18 kg/mc to 40 kg/mc.

**FIRST COATING** hot bonded polyester foam, velvet adhesion in polyester and/or 100% polyester wool, 200gr.

**CONTAINER BOTTOM** panels 12-14 mm in poplar wood particles class E1.

**TIGE** en pin et/ou boitiers en multicouche en bois de peuplier

**PANNEAUX** de 18/25 mm en particules de bois de peuplier classe E1 à faible émission de formaldéhyde et fibre de bois naturelle.

**POLYURÉTHANE EXPANSÉ** indéformable à portée différenciée, densité de 18kg/m<sup>3</sup> à 40kg/m<sup>3</sup>.

**PREMIER REVÊTEMENT** en polyester expansé accouplé à chaud à un velours accrochant en polyester et/ou ouate de polyester à 100% de 200g.

**PANNEAUX DE FOND COFFRE** rangement de 12-14mm en particules de bois de peuplier classe E1

**MASSIVES** Tannenholz und/oder Blöcke aus Pappelmehrschichtholz.

**SPANPLATTEN** aus Pappelholz mit 18/25 mm Schichtdicke der Klasse E1, geringer Formaldehydabgabe und natürlichen Holzfasern.

**POLYURETHANSCHAUM**, nicht verformbar und mit differenzierter Tragfähigkeit, Dichten von 18 kg/m<sup>3</sup> bis 40 kg/m<sup>3</sup>.

**ERSTER ÜBERZUG** aus Polyesterschaum, der auf Polyester-Samt und/oder 100% Polyesterwatte (zu 200 g) heiß aufkaschiert wurde.

**BODENPLATTEN** des Bettkastens aus 12-14 mm starken Spanplatten aus Pappelholz der Klasse E1.



## Optional

Rete / Support / Sommier / Lattenrost Pag 548

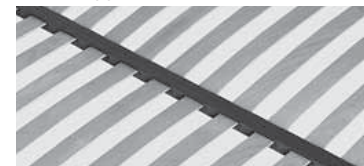

**Armony**  
(Standard)

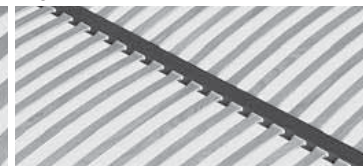

**Thai**  
46 doghe  
46 slats  
46 attes  
46 Leisten

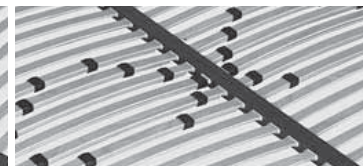

**Energy**  
Non applicabile a rete da 120 cm  
Not applicable to 120 cm support  
Non applicable au sommier de 120 cm  
Gilt nicht für Lattenrost zu 120 cm

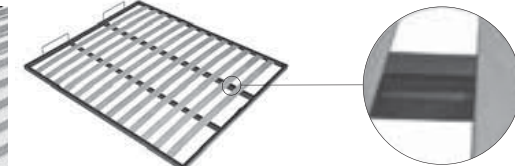

**Doppio Flip**  
Solo 140/160x190/200 - 180x200  
Only 140/160x190/200 - 180x200  
Uniquement 140/160x190/200 - 180x200  
Nur 140/160x190/200 - 180x200

Pag 552



**Sacco contenitore multiuso**  
Multipurpose storage bag  
Sac coffre de rangement multi usage  
Mehrzweck-Aufbewahrungstasche

Pag 553



**Tessuto coprirete traspirante antipolvere**  
Support cover fabric breathable and dustproof  
Tissu couvre-sommier transpirant anti-poussière  
Atmungsaktives, vor Staub schützendes Gewebe

Pag 557



**Regolatore altezza rete solo per reti in appoggio**  
Support height adjuster only for resting frames  
Réglage hauteur sommier uniquement pour sommiers à poser  
Lattenrost-Höhenverstellung nur für aufliegende Lattenroste

Pag 556



**Clean Up System**

## RING SMART



\* Rete L. 180 e L. 200 cm solo profondità 200 cm / Support W. 180 and W. 200 cm only D 200 cm / Sommier L. 180 et L. 200 cm uniquement en profondeur 200 cm / Attenrost B. 180 und B. 200 cm nur mit Tiefe 200 cm

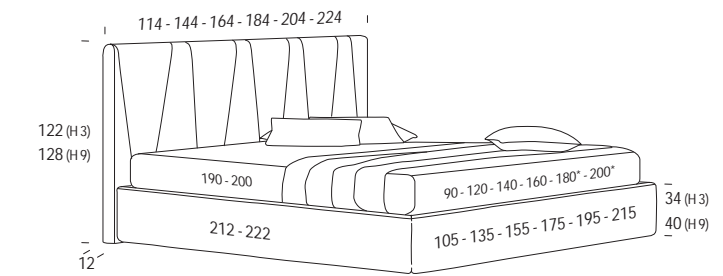

## Optional Pag 550

Meccanica / Mechanism / Mécanique / Mechanisch

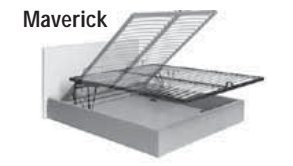
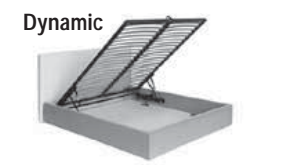

Standard BASIC H 3 Pag 545



Wengé / Wengé / Argent / Silber

Pag 545



Nero / Black / Noir / Schwarz

Optional LUX H 3 Pag 545



Wengé / Wengé / Argent / Silber

Pag 545



Nero / Black / Noir / Schwarz

Optional VISUAL H 9 Pag 545



Wengé / Wengé / Argent / Silber

Pag 545



Nero / Black / Noir / Schwarz



Argento / Silver / Argent / Silber



Bianco / White / Blanc / Weiß



Cromo / Chrome / Chrom / Chrom



Bianco / White / Blanc / Weiß



Argento / Silver / Argent / Silber



Bianco / White / Blanc / Weiß

## RING YORK



\* Rete L. 180 e L. 200 cm solo profondità 200 cm / Support W. 180 and W. 200 cm only D 200 cm / Sommier L. 180 et L. 200 cm uniquement en profondeur 200 cm / Attenrost B. 180 und B. 200 cm nur mit Tiefe 200 cm

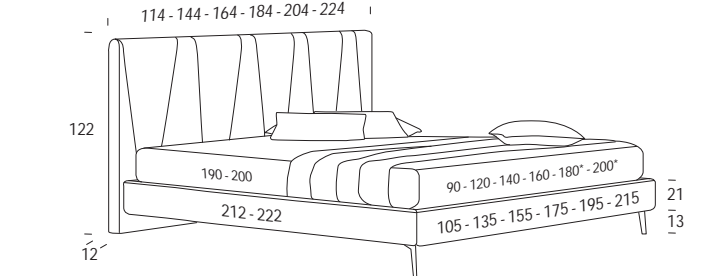

## Optional Pag 550

Meccanica / Mechanism / Mécanique / Mechanisch

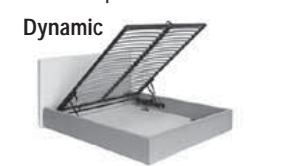

Standard BLADE H 13 Pag 546



Satinato / Satin / Satiné / Satiniert

Pag 546



Bronzato / Bronze / Bronze / Bronziert

Optional TOWER H 13 Pag 546



Optional PLEXY H 13 Pag 546



# Clyde



Le linee verticali rompono la rigidità e il rigore della testiera di Clyde. Due ring disponibili in base alle esigenze e al gusto: sollevato da terra, che dona una sensazione di leggerezza, o a pavimento, che lo rendono più autorevole.

The vertical lines break up the rigidity and restraint of the Clyde headboard. Two bed frames are available to suit your requirements and taste: raised from the floor to create a lighter feel, or at floor level to give a more authoritative air.

Les lignes verticales coupent la rigidité et la rigueur de la tête de lit de Clyde. Deux tours de lit sont disponibles à partir des exigences et du goût: soulevé du sol pour une sensation de légèreté ou au sol pour une plus grande autorité.

Die vertikalen Linien unterbrechen die beim Kopfteil von Clyde herrschende Steifheit und Strenge. Je nach Bedarf und Geschmack stehen zwei Gestelle zur Verfügung: ein vom Boden abgehobenes Gestell, das ein Gefühl von Leichtigkeit vermittelt, oder ein bodenstehendes, das mehr Autorität ausstrahlt.







La testiera alta e squadrata è "segnata" da una particolare trapuntatura a linee verticali.

The high and square headboard is "marked" by a particular quilting effect with vertical lines.

Le tête de lit haute et carrée est marquée par un rembourrage à lignes verticales.

Das hohe, kantige Kopfteil zeichnet sich durch eine spezielle Steppung mit vertikalen Linien aus.





# Clyde

COMPLETAMENTE SFODERABILE / COMPLETELY REMOVABLE FABRIC / COMPLÈTEMENT DÉHOUSSABLE / VOLLSTÄNDIG ABZIEHBAR

**MASSELLI** in legno di abete e/o scatolati in multistrato di legno di pioppo.

**PANNELLI** da 18/25 mm in particelle di legno di pioppo in classe E1 a bassa emissione di formaldeide e fibra di legno naturale.

**ESPANSI** di poliuretano indeformabile a portanza differenziata, densità da 18 kg/mc a 40 kg/mc.

**PRIMO RIVESTIMENTO** in espanso di poliestere accoppiato a caldo a vellutino aggrappante in poliestere e/o ovatta di poliestere al 100% da 200gr.

**PANNELLI FONDO** contenitore da 12-14 mm in particelle di legno di pioppo in classe E1.

**FORGINGS** fir wood, and/or boxed in poplar plywood.

**PANELS** 18/25 mm in poplar wood particles class E1 low formaldehyde emission and natural wood fiber.

**POLYURETHANE FOAM**, crushproof, of different capacity, density from 18 kg/mc to 40 kg/mc.

**FIRST COATING** hot bonded polyester foam, velvet adhesion in polyester and/or 100% polyester wool, 200gr.

**CONTAINER BOTTOM** panels 12-14 mm in poplar wood particles class E1.

**TIGE** en pin et/ou boitiers en multicouche en bois de peuplier

**PANNEAUX** de 18/25 mm en particules de bois de peuplier classe E1 à faible émission de formaldéhyde et fibre de bois naturelle.

**POLYURÉTHANE EXPANSÉ** indéformable à portée différenciée, densité de 18kg/m<sup>3</sup> à 40kg/m<sup>3</sup>.

**PREMIER REVÊTEMENT** en polyester expansé accouplé à chaud à un velours accrochant en polyester et/ou ouate de polyester à 100% de 200g.

**PANNEAUX DE FOND COFFRE** rangement de 12-14mm en particules de bois de peuplier classe E1

**MASSIVES** Tannenholz und/oder Blöcke aus Pappelmehrschichtholz.

**SPANPLATTEN** aus Pappelholz mit 18/25 mm Schichtdicke der Klasse E1, geringer Formaldehydabgabe und natürlichen Holzfasern.

**POLYURETHANSCHAUM**, nicht verformbar und mit differenzierter Tragfähigkeit, Dichten von 18 kg/m<sup>3</sup> bis 40 kg/m<sup>3</sup>.

**ERSTER ÜBERZUG** aus Polyesterschaum, der auf Polyester-Samt und/oder 100% Polyesterwatte (zu 200 g) heiß aufkaschiert wurde.

**BODENPLATTEN** des Bettkastens aus 12-14 mm starken Spanplatten aus Pappelholz der Klasse E1.



## Optional

Rete / Support / Sommier / Lattenrost Pag 548

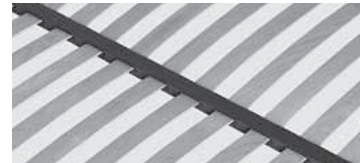

**Armony**  
(Standard)

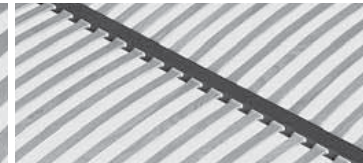

**Thai**  
46 doghe  
46 slats  
46attes  
46 Leisten

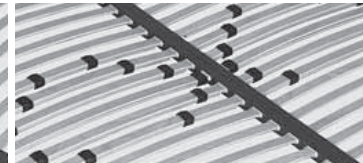

**Energy**  
Non applicabile a rete da 120 cm  
Not applicable to 120 cm support  
Non applicable au sommier de 120 cm  
Gilt nicht für Lattenrost zu 120 cm

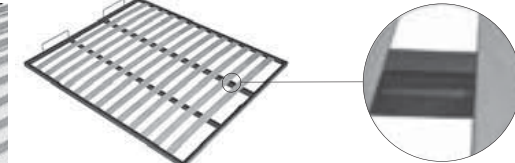

**Doppio Flip**  
Solo 140/160x190/200 - 180x200  
Only 140/160x190/200 - 180x200  
Uniquement 140/160x190/200 - 180x200  
Nur 140/160x190/200 - 180x200

Pag 552



**Sacco contenitore multiuso**  
Multipurpose storage bag  
Sac coffre de rangement multi usage  
Mehrzweck-Aufbewahrungstasche

Pag 553



**Tessuto coprirete traspirante antipolvere**  
Support cover fabric breathable and dustproof  
Tissu couvre-sommier transpirant anti-poussière  
Atmungsaktives, vor Staub schützendes Gewebe

Pag 557



**Regolatore altezza rete solo per reti in appoggio**  
Support height adjuster only for resting frames  
Réglage hauteur sommier uniquement pour sommiers à poser  
Lattenrost-Höhenverstellung nur für aufliegende Lattenroste

Pag 556



**Clean Up System**

## RING SMART

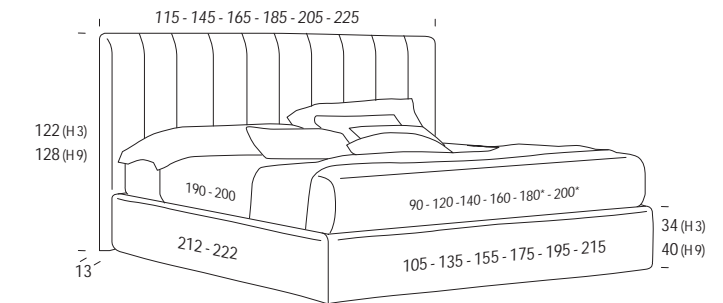

\* Rete L. 180 e L. 200 cm solo profondità 200 cm / Support W. 180 and W. 200 cm only D 200 cm / Sommier L. 180 et L. 200 cm uniquement en profondeur 200 cm / Attenrost B. 180 und B. 200 cm nur mit Tiefe 200 cm

Standard **BASIC H 3**



Wengé / Wengé  
/ Argent / Silber

Pag 545



Nero / Black  
/ Noir / Schwarz

Optional **LUX H 3**



Wengé / Wengé  
/ Wengé / Wengé

Pag 545



Nero / Black  
/ Noir / Schwarz

Optional **VISUAL H 9**



Wengé / Wengé  
/ Wengé / Wengé

Pag 545



Nero / Black  
/ Noir / Schwarz



Argento / Silver  
/ Argent / Silber



Bianco / White  
/ Blanc / Weiß



Cromo / Chrome  
/ Chromé / Chrom



Bianco / White  
/ Blanc / Weiß



Argento / Silver  
/ Argent / Silber



Bianco / White  
/ Blanc / Weiß

## Optional Pag 550

Meccanica / Mechanism  
/ Mécanique / Mechanisch

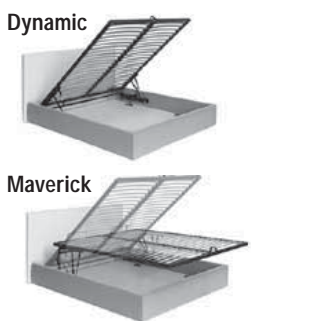

## RING YORK

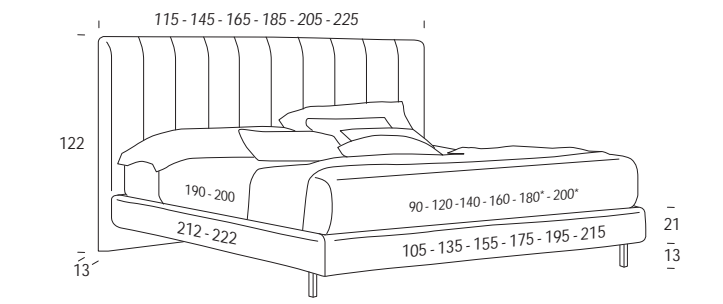

\* Rete L. 180 e L. 200 cm solo profondità 200 cm / Support W. 180 and W. 200 cm only D 200 cm / Sommier L. 180 et L. 200 cm uniquement en profondeur 200 cm / Attenrost B. 180 und B. 200 cm nur mit Tiefe 200 cm

Standard **BLADE H 13**



Satinato / Satin  
/ Satiné / Satiniert

Pag 546



Bronzato / Bronze  
/ Bronze / Bronziert

Optional **TOWER H 13**



Optional **PLEXY H 13**



Pag 546

## Optional Pag 550

Meccanica / Mechanism  
/ Mécanique / Mechanisch

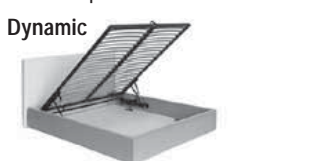

# Parker



Parker si distingue per l'unico grande cuscino che compone la testiera, decorato con un delicato bordo a volant.

Parker is rendered distinctive by the headrest consisting of a single large cushion decorated with a delicately frilled edge.

Parker se distingue par un seul grand coussin qui compose la tête de lit, décoré avec un bord à volant délicat.

Parker zeichnet sich durch ein einziges großes Kissen aus, das das Kopfteil bildet und mit einer zarten Volant-artigen Bordüre verziert ist.





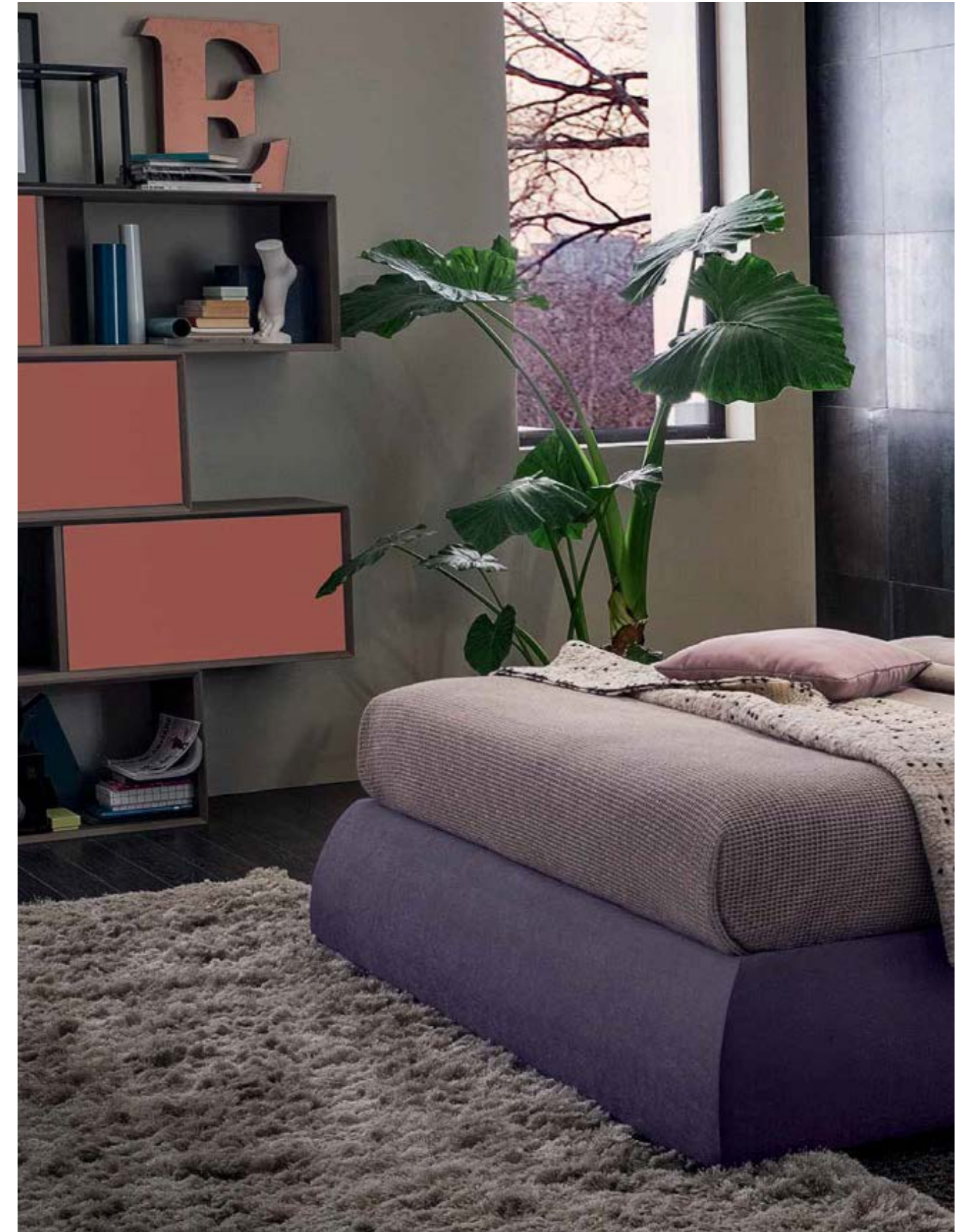

Il giroletto si arrotonda verso l'esterno e si allarga verso il basso aumentando la percezione di morbida accoglienza.

The bed frame is rounded towards the outside and extends downwards increasing the perception of welcoming softness.

Le tour de lit s'arrondit vers l'extérieur et s'élargit vers le bas pour augmenter la sensation d'enveloppement.

Der Bettrahmen ist nach außen hin abgerundet und wird nach unten hin breiter, was den Eindruck von weichem Komfort verstärkt.

# Parker

COMPLETAMENTE SFODERABILE / COMPLETELY REMOVABLE FABRIC / COMPLÈTEMENT DÉHOUSSABLE / VOLLSTÄNDIG ABZIEHBAR

**MASSELLI** in legno di abete e/o scatolati in multistrato di legno di pioppo.

**PANNELLI** da 18/25 mm in particelle di legno di pioppo in classe E1 a bassa emissione di formaldeide e fibra di legno naturale.

**ESPANSI** di poliuretano indeformabile a portanza differenziata, densità da 18 kg/mc a 40 kg/mc.

**PRIMO RIVESTIMENTO** in espanso di poliestere accoppiato a caldo a vellutino aggrappante in poliestere e/o ovatta di poliestere al 100% da 300gr.

**PANNELLI FONDO** contenitore da 12-14 mm in particelle di legno di pioppo in classe E1.

**FORGINGS** fir wood, and/or boxed in poplar plywood.

**PANELS** 18/25 mm in poplar wood particles class E1 low formaldehyde emission and natural wood fiber.

**POLYURETHANE FOAM**,

crushproof, of different capacity,

density from 18 kg/mc to 40 kg/mc.

**FIRST COATING** hot bonded

polyester foam, velvet adhesion in

polyester and/or 100% polyester

wool, 300gr.

**CONTAINER BOTTOM** panels

12-14 mm in poplar wood particles

class E1.

**TIGE** en pin et/ou boitiers en multicouche en bois de peuplier.

**PANNEAUX** de 18/25 mm en particules de bois de peuplier classe E1 à faible émission de formaldéhyde et fibre de bois naturelle.

**POLYURÉTHANE EXPANSÉ**

indéformable à portée différenciée,

densité de 18kg/m<sup>3</sup> à 40kg/m<sup>3</sup>.

**PREMIER REVÊTEMENT** en

polyester expansé accouplé à

chaud à un velours accrochant en

polyester et/ou ouate de polyester

à 100% de 300g.

**PANNEAUX DE FOND COFFRE**

rangement de 12-14mm en

particules de bois de peuplier

classe E1

**MASSIVES** Tannenholz und/oder Blöcke aus Pappelmehrschichtholz.

**SPANPLATTEN** aus Pappelholz mit 18/25 mm Schichtdicke der Klasse E1, geringer Formaldehydabgabe und natürlichen Holzfasern.

**POLYURETHANSCHAUM**, nicht

verformbar und mit differenzierter

Tragfähigkeit, Dichten von 18 kg/m<sup>3</sup>

bis 40 kg/m<sup>3</sup>.

**ERSTER ÜBERZUG** aus

Polyesterschaum, der auf

Polyester-Samt und/oder 100%

Polyesterwatte (zu 200 g) heiß

aufkaschiert wurde.

**BODENPLATTEN** des Bettkastens

aus 12-14 mm starken Spanplatten

aus Pappelholz der Klasse E1.



## RING ROUND

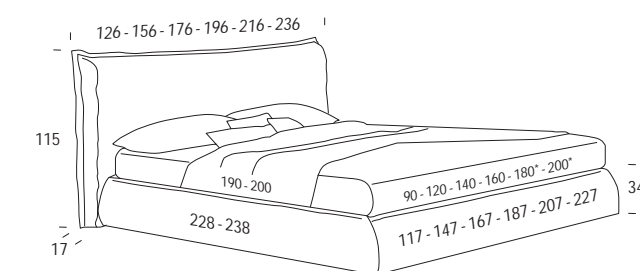

### Optional Pag 550

Meccanica / Mechanism / Mécanique / Mechanisch

Dynamic



Maverick



\* Rete L. 180 e L. 200 cm solo profondità 200 cm / Support W. 180 and W. 200 cm only D 200 cm / Sommier L. 180 et L. 200 cm uniquement en profondeur 200 cm / Attenrost B. 180 und B. 200 cm nur mit Tiefe 200 cm

### Optional

Rete / Support / Sommier / Lattenrost Pag 548

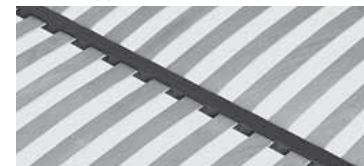

Armony (Standard)

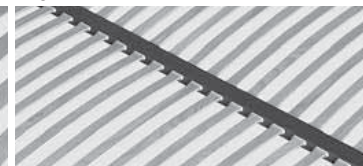

Thai  
46 doghe  
46 slats  
46attes  
46 Leisten

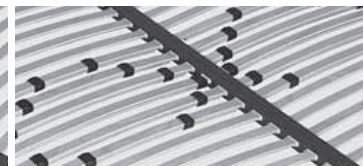

Energy  
Non applicabile a rete da 120 cm  
Not applicable to 120 cm support  
Non applicable au sommier de 120 cm  
Gilt nicht für Lattenrost zu 120 cm

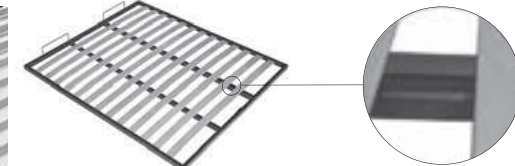

Doppio Flip  
Solo 140/160x190/200 - 180x200  
Only 140/160x190/200 - 180x200  
Uniquement 140/160x190/200 - 180x200  
Nur 140/160x190/200 - 180x200

Pag 552



Sacco contenitore multiuso  
Multipurpose storage bag  
Sac coffre de rangement multi usage  
Mehrzweck-Aufbewahrungstasche

Pag 553



Tessuto coprirete traspirante antipolvere  
Support cover fabric breathable and dustproof  
Tissu couvre-sommier transpirant anti-poussière  
Atmungsaktives, vor Staub schützendes Gewebe

Pag 557



Regolatore altezza rete solo per reti in appoggio  
Support height adjuster only for resting frames  
Réglage hauteur sommier uniquement pour sommiers à poser  
Lattenrost-Höhenverstellung nur für aufliegende Lattenroste

Pag 556



Clean Up System

Standard BASIC H 3



Wengé / Wengé  
/ Wengé / Wengé

Pag 545



Nero / Black  
/ Noir / Schwarz

Optional LUX H 3



Wengé / Wengé  
/ Wengé / Wengé

Pag 545



Nero / Black  
/ Noir / Schwarz



Argento / Silver  
/ Argent / Silber



Bianco / White  
/ Blanc / Weiß



Cromo / Chrome  
/ Chrome / Chrom



Bianco / White  
/ Blanc / Weiß

# Chris



Le linee geometriche di Chris lo rendono rigoroso e intransigente, ma i bottoni uniti da un'originale finitura ammorbidiscono la meticolosità di questo design.

The geometric lines of Chris make it rigorous and uncompromising, but its buttons joined by a unique finishing smooth the accuracy of this design.

Les lignes géométriques de Chris le rendent rigoureux et intransigent, mais les boutons combinés à une finition originale adoucissent la méticulosité de son design.

Durch die geometrischen Linien wirkt Chris streng und kompromisslos, aber die Knöpfe, die durch eine originelle Verarbeitung bestechen, lassen dieses akkurate Design weicher erscheinen.

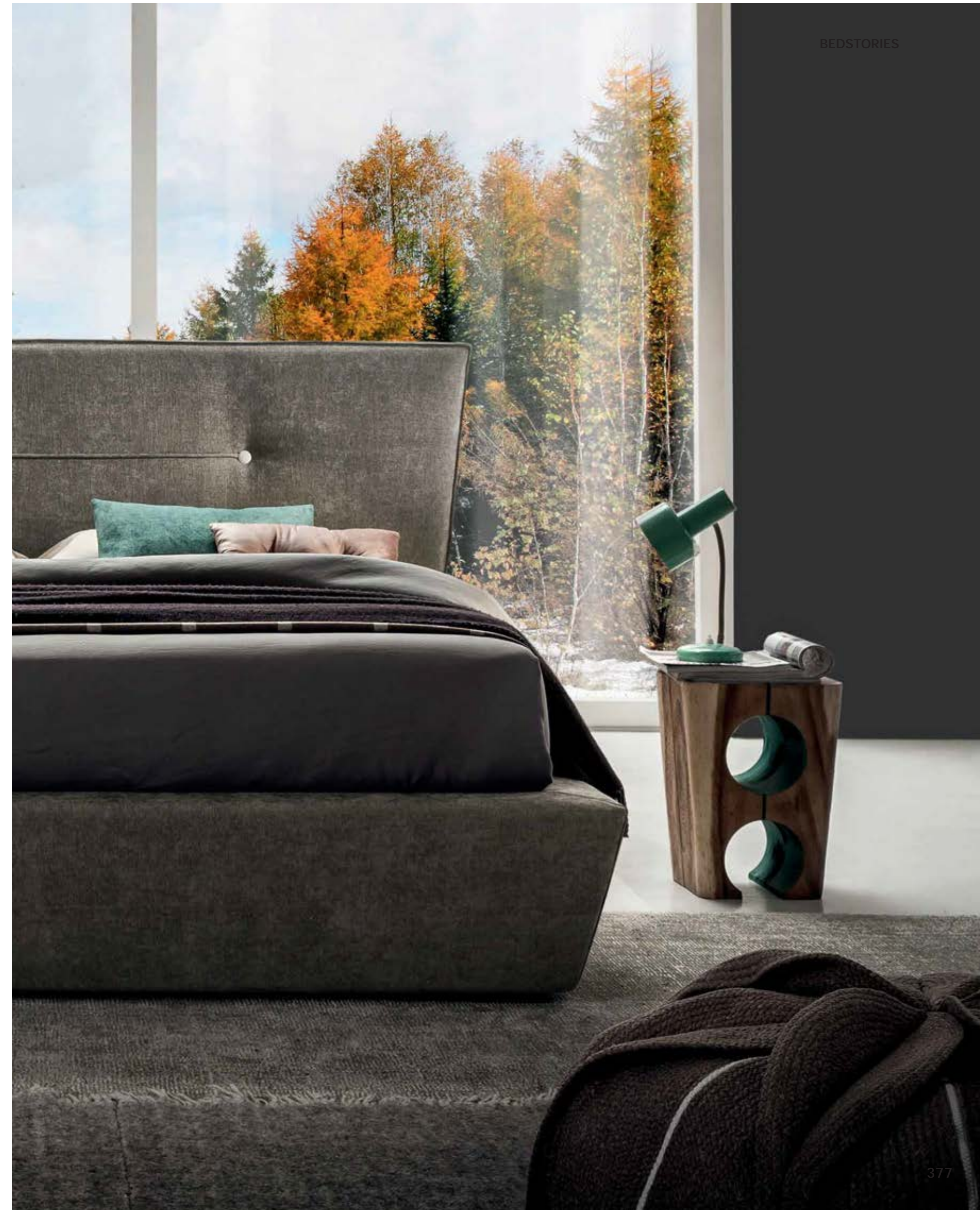









# Chris

COMPLETAMENTE SFODERABILE / COMPLETELY REMOVABLE FABRIC / COMPLÈTEMENT DÉHOUSSABLE / VOLLSTÄNDIG ABZIEHBAR

**MASSELLI** in legno di abete e/o scatolati in multistrato di legno di pioppo.

**PANNELLI** da 18/25 mm in particelle di legno di pioppo in classe E1 a bassa emissione di formaldeide e fibra di legno naturale.

**ESPANSI** di poliuretano indeformabile a portanza differenziata, densità da 18 kg/mc a 40 kg/mc.

**PRIMO RIVESTIMENTO** in espanso di poliestere accoppiato a caldo a vellutino aggrappante in poliestere e/o ovatta di poliestere al 100% da 200gr.

**PANNELLI FONDO** contenitore da 12-14 mm in particelle di legno di pioppo in classe E1.

**FORGINGS** fir wood, and/or boxed in poplar plywood. **PANELS** 18/25 mm in poplar wood particles class E1 low formaldehyde emission and natural wood fiber.

**POLYURETHANE FOAM**, crushproof, of different capacity, density from 18 kg/mc to 40 kg/mc.

**FIRST COATING** hot bonded polyester foam, velvet adhesion in polyester and/or 100% polyester wool, 200gr.

**CONTAINER BOTTOM** panels 12-14 mm in poplar wood particles class E1.

**TIGE** en pin et/ou boitiers en multicouche en bois de peuplier.

**PANNEAUX** de 18/25 mm en particules de bois de peuplier classe E1 à faible émission de formaldéhyde et fibre de bois naturelle.

**POLYURÉTHANE EXPANSÉ** indéformable à portée différenciée, densité de 18kg/m<sup>3</sup> à 40kg/m<sup>3</sup>.

**PREMIER REVÊTEMENT** en polyester expansé accouplé à chaud à un velours accrochant en polyester et/ou ouate de polyester à 100% de 200g.

**PANNEAUX DE FOND COFFRE** coffre rangement de 12-14mm en particules de bois de peuplier classe E1.

**MASSIVES** Tannenholz und/oder Blöcke aus Pappelmeerschholz.

**SPANPLATTEN** aus Pappelholz mit 18/25 mm Schichtdicke der Klasse E1, geringer Formaldehydabgabe und natürlichen Holzfasern.

**POLYURETHANSCHAUM**, nicht verformbar und mit differenzierter Tragfähigkeit, Dichten von 18 kg/m<sup>3</sup> bis 40 kg/m<sup>3</sup>.

**ERSTER ÜBERZUG** aus Polyesterschaum, der auf Polyester-Samt und/oder 100% Polyesterwatte (zu 200 g) heiß aufkaschiert wurde.

**BODENPLATTEN** des Bettkastens aus 12-14 mm starken Spanplatten aus Pappelholz der Klasse E1.

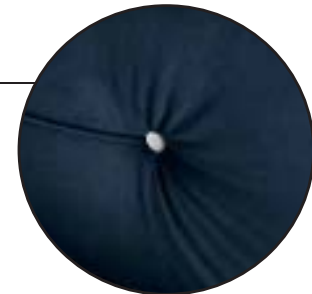

Bottoni in tinta unita o a contrasto o Swarovski bianco o nero.  
/ Buttons in the same color as the fabric, or contrasting, or mixed colors or black or white Swarovski.  
/ Boutons couleur tissu ou en contraste ou mélange de couleur ou Swarovski blanc ou noir.  
/ Knöpfe in der gleichen Farbe oder in einer Kontrastfarbe oder Swarovskis in Weiß oder Schwarz.



Bottoni in tinta o a contrasto oppure Swarovski bianco o nero.  
Matching colour, contrasting or black or white Swarovski.  
Boutons en teinte ou en contraste, ou Swarovski blanc ou noir.  
Knöpfe in der gleichen Farbe oder in einer Kontrastfarbe oder Swarovskis in Weiß oder Schwarz.

## RING CLIMB

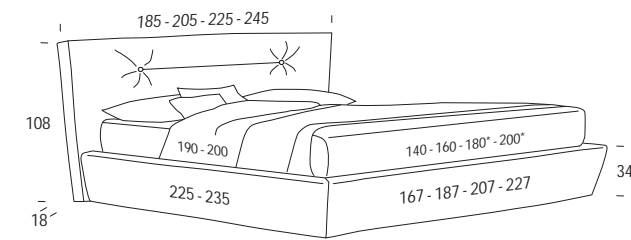

\* Rete L. 180 e L. 200 cm solo profondità 200 cm / Support W. 180 and W. 200 cm only D 200 cm  
/ Sommier L. 180 et L. 200 cm uniquement en profondeur 200 cm / Attenrost B. 180 und B. 200 cm nur mit Tiefe 200 cm

## Optional Pag 550

Meccanica / Mechanism  
/ Mécanique / Mechanisch

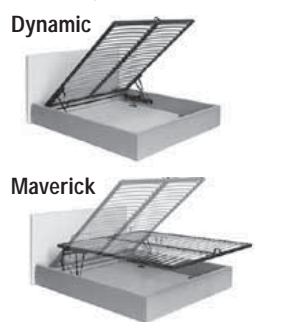

## Optional

Rete / Support / Sommier / Lattenrost Pag 548

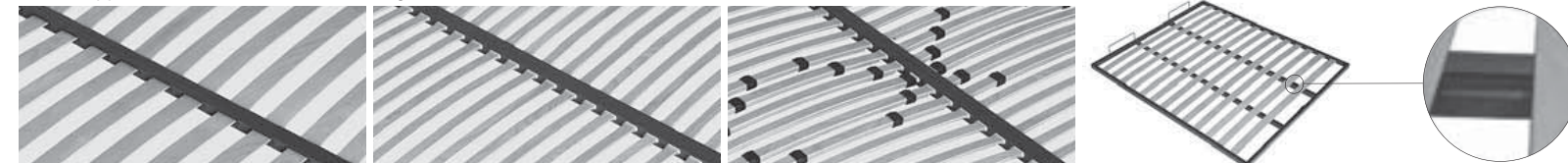

Armony (Standard)

Thai  
46 doghe  
46 slats  
46 attes  
46 Leisten

Energy  
Non applicabile a rete da 120 cm  
Not applicable to 120 cm support  
Non applicable au sommier de 120 cm  
Gilt nicht für Lattenrost zu 120 cm

Doppio Flip  
Solo 140/160x190/200 - 180x200  
Only 140/160x190/200 - 180x200  
Uniquement 140/160x190/200 - 180x200  
Nur 140/160x190/200 - 180x200

Pag 552



Sacco contenitore multiuso  
Multipurpose storage bag  
Sac coffre de rangement multi usage  
Mehrzweck-Aufbewahrungstasche

Pag 553



Tessuto coprirete traspirante antipolvere  
Support cover fabric breathable and dustproof  
Tissu couvre-sommier transpirant anti-poussière  
Atmungsaktives, vor Staub schützendes Gewebe

Pag 557



Regolatore altezza rete solo per reti in appoggio  
Support height adjuster only for resting frames  
Réglage hauteur sommier uniquement pour sommiers à poser  
Lattenrost-Höhenverstellung nur für aufliegende Lattenroste

Pag 556



Clean Up System

Standard BASIC H 3

Pag 545



Wengé / Wengé  
/ Wengé / Wengé



Nero / Black  
/ Noir / Schwarz

Optional LUX H 3

Pag 545



Wengé / Wengé  
/ Wengé / Wengé



Nero / Black  
/ Noir / Schwarz



Argento / Silver  
/ Argent / Silber



Bianco / White  
/ Blanc / Weiß



Cromo / Chrome  
/ Chrome / Chrom



Bianco / White  
/ Blanc / Weiß

# Easy Collection

La semplicità, quella vera, è ricerca dell'essenza. Mette in luce il fascino dell'eleganza, evitando il superfluo. I modelli Easy si muovono in questa direzione: linee pulite che svelano personalità cangianti a seconda dei tessuti e delle cromie scelte, soluzioni funzionali che semplificano la vita di tutti i giorni. Perché Easy è una collezione, ma è anche uno stile di vita.

Simplicity, the real one, is the search for the core. It highlights the charm of elegance avoiding the unnecessary. The Easy models move in this direction: clean designs revealing changing characters depending on textiles and colours schemes chosen, practical solutions making simpler the everyday life. Because Easy is a collection, but also a lifestyle.

La simplicité, la vraie, est une recherche de l'essence. Elle met en évidence le charme de l'élégance, en évitant le superflu. Les modèles Easy suivent cette direction : lignes propres qui dévoilent une personnalité chatoyante selon les tissus et les couleurs choisies, des solutions fonctionnelles qui simplifient la vie de tous les jours. Parce qu'Easy est une collection, mais aussi un style de vie.

Die Schlichtheit, wahre Schlichtheit, ist die Suche nach dem Wesentlichen. Sie unterstreicht den Charme der Eleganz und vermeidet das Überflüssige. Und die Modelle aus der Easy Collection bewegen sich genau in diese Richtung: saubere Linien, die je nach den gewählten Stoffen und Farben unterschiedliche Persönlichkeiten offenbaren, funktionelle Lösungen, die den Alltag erleichtern. Denn Easy ist nicht nur eine Kollektion, sondern auch ein Lebensstil.

# Arley - A/B

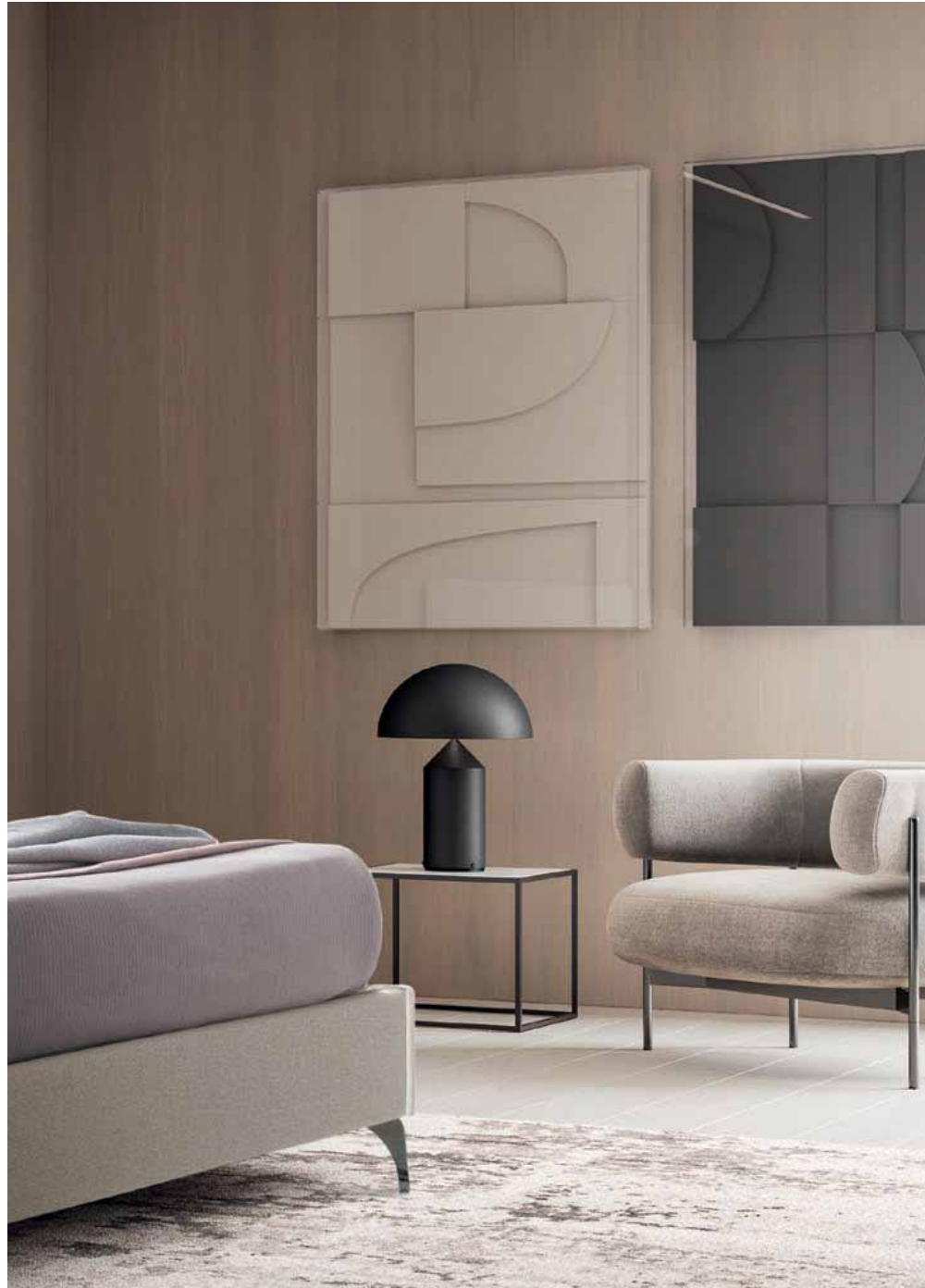

Morbido e accogliente, Arley ha ampi cuscini come testiera, perfetti per immergersi comodamente in un buon libro. L'attenzione agli ingombri lo rende adatto a ogni tipo di ambiente.

Soft and cosy, Arley's headboard has large cushions, perfect to easily revel in a good reading. The overall dimensions are designed to adapt it to any environment.

Souple et accueillant, Arley propose comme tête de lit d'amples coussins, parfaits pour s'immerger confortablement dans un bon livre. L'attention portée aux encombrements fait si qu'il s'adapte à quelconque type de milieu.

Das weiche und einladende Modell Arley verfügt über große Kissen, die als Kopfteil fungieren und perfekt sind, um sich bequem in ein gutes Buch zu vertiefen. Durch die sorgfältig gewählten Abmessungen passt es in jedes Ambiente.





# Arley - A

## Versione con cuciture lineari

Version with linear stitchings  
Version avec coutures linéaires  
Version mit linearen Nähten

Le cuciture lineari dei cuscini in questa versione rendono Arley aggraziato e delicato.

The linear stitchings of the cushions give Arley an elegant and delicate air.

En cette version, les coutures linéaires des coussins rendent Arley gracieux et délicat.

Die linearen Nähte bei den Kissen dieser Ausführung lassen Arley anmutig und zart erscheinen.



# Arley - B

## Versione con plissé

Version with plissé  
Version avec plissé  
Version mit Falten

Nella versione B di Arley, le cuciture esaltano la morbidezza e dei cuscini.

In the version B of Arley, the stitchings enhance the softness of the cushions.

Dans la version B d'Arley, les coutures exaltent la souplesse des coussins.

In der B-Version von Arley heben die Nähte die Weichheit der Kissen hervor.





# Arley - A/B

COMPLETAMENTE SFODERABILE / COMPLETELY REMOVABLE FABRIC / COMPLÈTEMENT DÉHOUSSABLE / VOLLSTÄNDIG ABZIEHBAR

**MASSELLI** in legno di abete e/o scatolati in multistrato di legno di pioppo.  
**PANNELLI** da 18/25 mm in particelle di legno di pioppo in classe E1 a bassa emissione di formaldeide e fibra di legno naturale.  
**ESPANSI** di poliuretano indeformabile a portanza differenziata, densità da 18 kg/mc a 40 kg/mc.  
**PRIMO RIVESTIMENTO** in espanso di poliestere accoppiato a caldo a vellutino aggrappante in poliestere e/o ovatta di poliestere al 100% da 200gr.  
**PANNELLI FONDO** contenitore da 12-14 mm in particelle di legno di pioppo in classe E1.

**FORGINGS** fir wood, and/or boxed in poplar plywood.  
**PANELS** 18/25 mm in poplar wood particles class E1 low formaldehyde emission and natural wood fiber.  
**POLYURETHANE FOAM**, crushproof, of different capacity, density from 18 kg/mc to 40 kg/mc.  
**FIRST COATING** hot bonded polyester foam, velvet adhesion in polyester and/or 100% polyester wool, 200gr.  
**CONTAINER BOTTOM** panels 12-14 mm in poplar wood particles class E1.

**TIGE** en pin et/ou boitiers en multicouche en bois de peuplier.  
**PANNEAUX** de 18/25 mm en particules de bois de peuplier classe E1 à faible émission de formaldéhyde et fibre de bois naturelle.  
**POLYURÉTHANE EXPANSÉ** indéformable à portée différenciée, densité de 18kg/m<sup>3</sup> à 40kg/m<sup>3</sup>.  
**PREMIER REVÊTEMENT** en polyester expansé accouplé à chaud à un velours accrochant en polyester et/ou ouate de polyester à 100% de 200g.  
**PANNEAUX DE FOND** coffre rangement de 12-14mm en particules de bois de peuplier classe E1

**MASSIVES** Tannenholz und/oder Blöcke aus Pappelmehrschichtholz.  
**SPANPLATTEN** aus Pappelholz mit 18/25 mm Schichtdicke der Klasse E1, geringer Formaldehydabgabe und natürlichen Holzfasern.  
**POLYURETHANSCHAUM**, nicht verformbar und mit differenzierter Tragfähigkeit, Dichten von 18 kg/m<sup>3</sup> bis 40 kg/m<sup>3</sup>.  
**ERSTER ÜBERZUG** aus Polyesterschaum, der auf Polyester-Samt und/oder 100% Polyesterwatte (zu 200 g) heiß aufkaschiert wurde.  
**BODENPLATTEN** des Bettkastens aus 12-14 mm starken Spanplatten aus Pappelholz der Klasse E1.

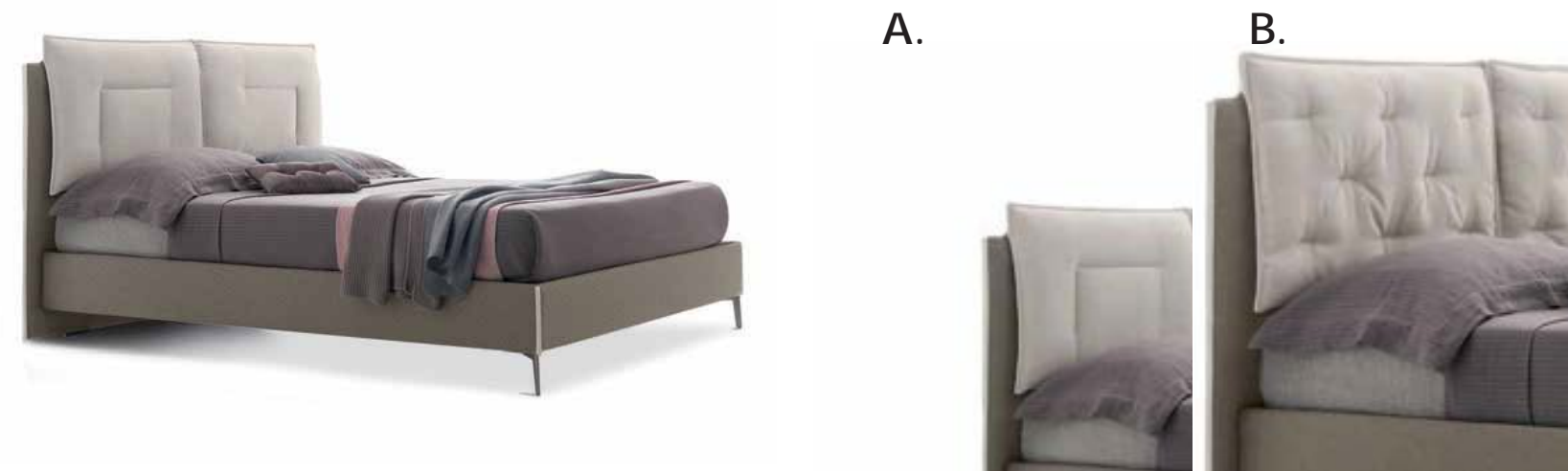

## Optional

Rete / Support / Sommier / Lattenrost Pag 548

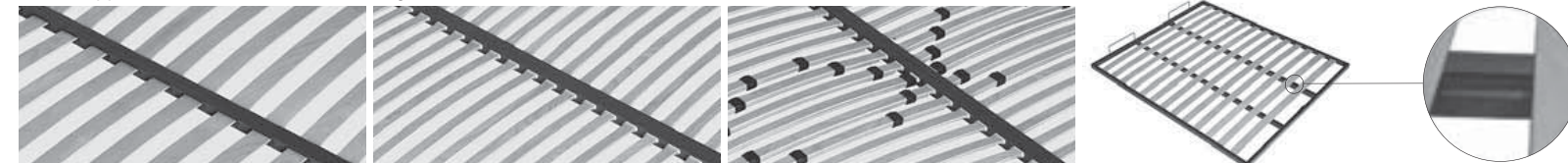

**Armony**  
(Standard)

**Thai**  
46 doghe  
46 slats  
46 attes  
46 Leisten

**Energy**  
Non applicabile a rete da 120 cm  
Not applicable to 120 cm support  
Non applicable au sommier de 120 cm  
Gilt nicht für Lattenrost zu 120 cm

**Doppio Flip**  
Solo 140/160x190/200 - 180x200  
Only 140/160x190/200 - 180x200  
Uniquement 140/160x190/200 - 180x200  
Nur 140/160x190/200 - 180x200

Pag 552



**Sacco contenitore multiuso**  
Multipurpose storage bag  
Sac coffre de rangement multi usage  
Mehrzweck-Aufbewahrungstasche

Pag 553



**Tessuto coprirete traspirante antipolvere**  
Support cover fabric breathable and dustproof  
Tissu couvre-sommier transpirant anti-poussière  
Atmungsaktives, vor Staub schützendes Gewebe

Pag 557



**Regolatore altezza rete solo per reti in appoggio**  
Support height adjuster only for resting frames  
Réglage hauteur sommier uniquement pour sommiers à poser  
Lattenrost-Höhenverstellung nur für aufliegende Lattenroste

Pag 556



**Clean Up System**

## RING SMART

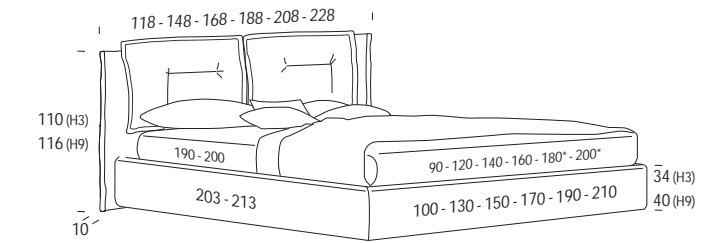

\* Rete L. 180 e L. 200 cm solo profondità 200 cm / Support W. 180 and W. 200 cm only D 200 cm / Sommier L. 180 et L. 200 cm uniquement en profondeur 200 cm / Attenrost B. 180 und B. 200 cm nur mit Tiefe 200 cm

Standard **BASIC H 3**



Wengé / Wengé  
/ Wengé / Wengé



Argento / Silver  
/ Argent / Silber

Pag 545



Nero / Black  
/ Noir / Schwarz



Bianco / White  
/ Blanc / Weiß

Optional **LUX H 3**



Wengé / Wengé  
/ Wengé / Wengé



Cromo / Chrome  
/ Chrome / Chrom

Pag 545



Nero / Black  
/ Noir / Schwarz



Bianco / White  
/ Blanc / Weiß

Optional **VISUAL H 9**



Wengé / Wengé  
/ Wengé / Wengé



Argento / Silver  
/ Argent / Silber

Pag 545



Nero / Black  
/ Noir / Schwarz



Bianco / White  
/ Blanc / Weiß

## Optional Pag 550

Meccanica / Mechanism  
/ Mécanique / Mechanisch

Dynamic



Maverick

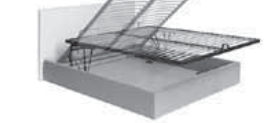

## RING YORK

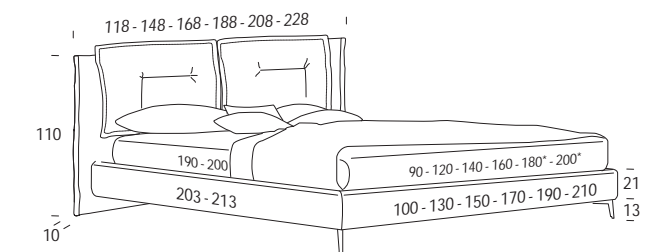

\* Rete L. 180 e L. 200 cm solo profondità 200 cm / Support W. 180 and W. 200 cm only D 200 cm / Sommier L. 180 et L. 200 cm uniquement en profondeur 200 cm / Attenrost B. 180 und B. 200 cm nur mit Tiefe 200 cm

Standard **BLADE H 13**



Satinato / Satin  
/ Satiné / Satiniert

Pag 546



Bronzato / Bronze  
/ Bronze / Bronziert

Optional **TOWER H 13**



Optional **PLEXY H 13**



Pag 546

## Optional Pag 550

Meccanica / Mechanism  
/ Mécanique / Mechanisch

Dynamic

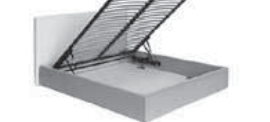



# Tim - A/B



Testiera essenziale e leggera, razionale nel disegno e negli spessori. Tim interpreta lo spazio in cui si trova, adattandosi ogni volta ad ambienti di diverso carattere.

Headboard basic and light, with rational thicknesses and design. Tim interprets the space in which it is located adapting each time to environments of different character.

Tête de lit essentiel et léger, rationnel dans son design et dans ses épaisseurs. Tim interprète l'espace dans lequel il se trouve, en s'adaptant à chaque fois à des milieux aux caractères différents.

Ein schlichtes und leichtes Kopfteil, rational in Design und Schichtdicke. Tim interpretiert den Raum, in dem es steht, und passt sich jedes Mal an Umgebungen mit unterschiedlichem Charakter an.







TIM - A

## Tim - B



Un modello di proporzioni impeccabili ed equilibrate contraddistinto, nella versione B, dalla particolare lavorazione della testiera, suddivisa in fasce verticali con impunture equidistanti. Tim è ideale per chi ama i dettagli, ma non vuole rinunciare al comfort e alla praticità.

A model with perfect and balanced dimensions marked, in version B, by a special processing of the headboard divided in vertical bands with topstitchings at equal distance. Tim is ideal for those who love particulars but don't want to do without comfort and ease.

Un modèle distingué aux proportions impeccables et équilibrées, dans la version B, grâce à un travail particulier de la tête de lit, divisée en bandes verticales avec des coutures équidistantes. Tim est idéal pour les personnes qui aiment les détails, mais qui ne veulent pas renoncer au confort et à la praticité.

Ein Modell mit tadellosen und ausgewogenen Proportionen, das sich in der Version B durch die besondere Verarbeitung des Kopfteils auszeichnet, das in vertikale Streifen mit gleichmäßig angeordneten Nähten unterteilt ist. Tim ist ideal für alle, die Details lieben, nicht aber auf Komfort und Zweckmäßigkeit verzichten möchten.

# Tim - A

## Versione con testiera liscia e bordo a goccia

Version with smooth headboard and drip trim

Version avec tête de lit lisse et bord en goutte

Ausführung mit glattem Kopfteil und tropfenförmigem Rand

Testiera essenziale e leggera, razionale nel disegno e negli spessori. Il rivestimento viene impreziosito ai lati da dei bordi a volant, disponibili a contrasto o in tinta, che tracciano il contorno di Tim-A.

Headboard basic and light, with rational thicknesses and design. The covering is enriched on the sides by frilled trims, available in the same colour or contrasting, tracing the contour of Tim-A.

Tête de lit essentielle et légère, au design et aux épaisseurs rationnels. Les côtés du revêtement sont enrichis par des volants, disponibles en teinte ou en contraste, qui tracent le contour de Tim-A.

Ein schlichtes und leichtes Kopfteil, rational in Design und Schichtdicke. Der Bezug wird an den Seiten mit gleichfarbigen oder farblich abgesetzten, Volant-artigen Borten verziert, die das Profil von Tim-A nachzeichnen.



# Tim - B

## Versione con cuciture verticali testiera

Version with headboard vertical stitchings

Version avec tête de lit aux coutures verticales

Ausführung mit vertikalen Nähten am Kopfteil

Sottile e delicato. Il design salvaspazio di Tim-B non rinuncia allo stile; la testiera con impunture crea un ritmo visivo elegante, adattandosi anche agli ambienti più stretti.

Thin and delicate. The space-saving design of Tim-B wants to be fashionable; the headboard with topstitchings creates a stylish visual rhythm, adapting also to narrower spaces.

Fin et délicat. Le design sauve-espace de Tim-B ne renonce pas au style ; la tête de lit avec coutures crée un rythme visuel élégant, en s'adaptant également aux milieux plus étroits.

Schlank und zart. Das platzsparende Design von Tim-B geht nicht auf Kosten des Stils; das gesteppte Kopfteil schafft einen eleganten visuellen Rhythmus und passt sich selbst kleinen Räumen an.



# Tim - A

## Versione con testiera liscia

Version with smooth headboard

Version avec tête de lit lisse

Ausführung mit glattem Kopfteil



**TIM "A"**  
**RING SMART**  
liscio / smooth  
/ lisse / glatt



**TIM "A"**  
**RING YORK**  
liscio / smooth  
/ lisse / glatt

# Tim - B

## Versione con cuciture verticali

Version with vertical stitchings

Version avec coutures verticales

Ausführung mit vertikalen Nähten



**TIM "B"**  
**RING SMART**  
con cuciture / with stitchings  
/ avec coutures / mit Nähten



**TIM "B"**  
**RING YORK**  
con cuciture / with stitchings  
/ avec coutures / mit Nähten



Linee pulite e dettagli sobri che trovano margine anche sul ring: un punto di luce dato da dei piccoli volant realizzabili in tinta o in contrasto.

Clean lines and simple particulars surrounding also the ring: a point of light provided by small frills feasible in the same colour or contrasting.

Lignes propres et détails sobres qui trouvent une marge également sur le cadre du lit : un point de lumière donné par de petits volants réalisés en teinte ou en contraste.

Eine saubere Linienführung und schlichte Details sind auch am Bettgestell anzutreffen: die kleinen, Ton-in-Ton oder in einer Kontrastfarbe ausgeführten Volants fallen sofort ins Auge.

# Tim - A/B

COMPLETAMENTE SFODERABILE / COMPLETELY REMOVABLE FABRIC / COMPLÈTEMENT DÉHOUSSABLE / VOLLSTÄNDIG ABZIEHBAR

**MASSELLI** in legno di abete e/o scatolati in multistrato di legno di pioppo.

**PANNELLI** da 18/25 mm in particelle di legno di pioppo in classe E1 a bassa emissione di formaldeide e fibra di legno naturale.

**ESPANSI** di poliuretano indeformabile a portanza differenziata, densità da 18 kg/mc a 40 kg/mc.

**PRIMO RIVESTIMENTO** in espanso di poliestere accoppiato a caldo a vellutino aggrappante in poliestere e/o ovatta di poliestere al 100% da 200gr.

**PANNELLI FONDO** contenitore da 12-14 mm in particelle di legno di pioppo in classe E1.

**FORGINGS** fir wood, and/or boxed in poplar plywood.

**PANELS** 18/25 mm in poplar wood particles class E1 low formaldehyde emission and natural wood fiber.

**POLYURETHANE FOAM**, crushproof, of different capacity, density from 18 kg/mc to 40 kg/mc.

**FIRST COATING** hot bonded polyester foam, velvet adhesion in polyester and/or 100% polyester wool, 200gr.

**CONTAINER BOTTOM** panels 12-14 mm in poplar wood particles class E1.

**TIGE** en pin et/ou boitiers en multicouche en bois de peuplier.

**PANNEAUX** de 18/25 mm en particules de bois de peuplier classe E1 à faible émission de formaldéhyde et fibre de bois naturelle.

**POLYURÉTHANE EXPANSÉ** indéformable à portée différenciée, densité de 18kg/m<sup>3</sup> à 40kg/m<sup>3</sup>.

**PREMIER REVÊTEMENT** en polyester expansé accouplé à chaud à un velours accrochant en polyester et/ou ouate de polyester à 100% de 200g.

**PANNEAUX DE FOND** coffre rangement de 12-14mm en particules de bois de peuplier classe E1

**MASSIVES** Tannenholz und/oder Blöcke aus Pappelmehrschichtholz.

**SPANPLATTEN** aus Pappelholz mit 18/25 mm Schichtdicke der Klasse E1, geringer Formaldehydabgabe und natürlichen Holzfasern.

**POLYURETHANSCHAUM**, nicht verformbar und mit differenzierter Tragfähigkeit, Dichten von 18 kg/m<sup>3</sup> bis 40 kg/m<sup>3</sup>.

**ERSTER ÜBERZUG** aus Polyesterschaum, der auf Polyester-Samt und/oder 100% Polyesterwatte (zu 200 g) heiß aufkaschiert wurde.

**BODENPLATTEN** des Bettkastens aus 12-14 mm starken Spanplatten aus Pappelholz der Klasse E1.

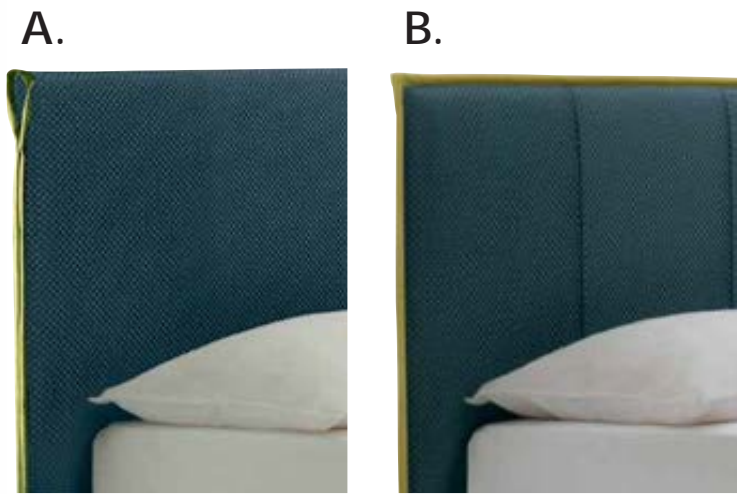

## Optional

Rete / Support / Sommier / Lattenrost Pag 548

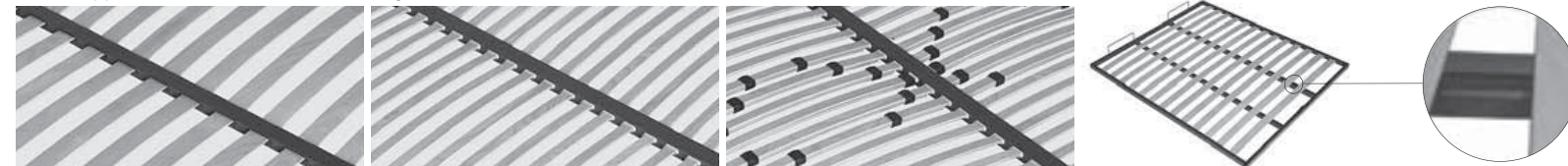

**Armony** (Standard)

**Thai**  
46 doghe  
46 slats  
46 attes  
46 Leisten

**Energy**

Non applicabile a rete da 120 cm  
Not applicable to 120 cm support  
Non applicable au sommier de 120 cm  
Gilt nicht für Lattenrost zu 120 cm

**Doppio Flip**

Solo 140/160x190/200 - 180x200  
Only 140/160x190/200 - 180x200  
Uniquement 140/160x190/200 - 180x200  
Nur 140/160x190/200 - 180x200

Pag 552



**Sacco contenitore multiuso**  
Multipurpose storage bag  
Sac coffre de rangement multi usage  
Mehrzweck-Aufbewahrungstasche

Pag 553



**Tessuto coprirete traspirante antipolvere**  
Support cover fabric breathable and dustproof  
Tissu couvre-sommier transpirant anti-poussière  
Atmungsaktives, vor Staub schützendes Gewebe

Pag 557



**Regolatore altezza rete solo per reti in appoggio**  
Support height adjuster only for resting frames  
Réglage hauteur sommier uniquement pour sommiers à poser  
Lattenrost-Höhenverstellung nur für aufliegende Lattenroste

Pag 556



**Clean Up System**

## RING SMART

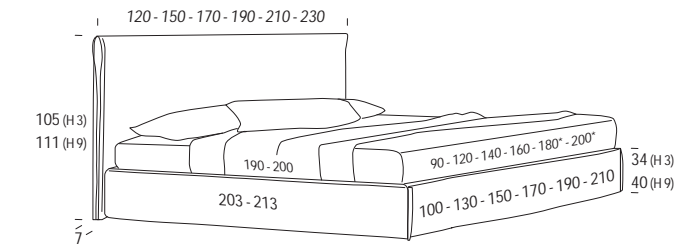

\* Rete L. 180 e L. 200 cm solo profondità 200 cm / Support W. 180 and W. 200 cm only D 200 cm / Sommier L. 180 et L. 200 cm uniquement en profondeur 200 cm / Attenrost B. 180 und B. 200 cm nur mit Tiefe 200 cm

Standard **BASIC H 3**



Wengé / Wengé  
/ Wengé / Wengé



Argento / Silver  
/ Argent / Silber

Pag 545



Nero / Black  
/ Noir / Schwarz



Bianco / White  
/ Blanc / Weiß

Optional **LUX H 3**



Wengé / Wengé  
/ Wengé / Wengé



Cromo / Chrome  
/ Chrome / Chrom

Pag 545



Nero / Black  
/ Noir / Schwarz



Bianco / White  
/ Blanc / Weiß

Optional **VISUAL H 9**



Wengé / Wengé  
/ Wengé / Wengé



Argento / Silver  
/ Argent / Silber

Pag 545



Nero / Black  
/ Noir / Schwarz



Bianco / White  
/ Blanc / Weiß

## Optional Pag 550

Meccanica / Mechanism  
/ Mécanique / Mechanisch

Dynamic



Maverick



## RING YORK

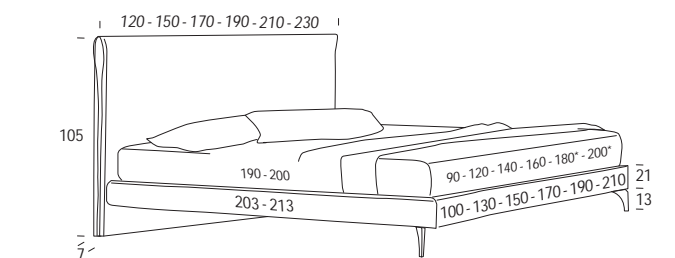

\* Rete L. 180 e L. 200 cm solo profondità 200 cm / Support W. 180 and W. 200 cm only D 200 cm / Sommier L. 180 et L. 200 cm uniquement en profondeur 200 cm / Attenrost B. 180 und B. 200 cm nur mit Tiefe 200 cm

Standard **BLADE H 13**



Satinato / Satin  
/ Satiné / Satiniert

Pag 546



Bronzato / Bronze  
/ Bronze / Bronziert

Optional **TOWER H 13**



Optional **PLEXY H 13**



Pag 546

## Optional Pag 550

Meccanica / Mechanism  
/ Mécanique / Mechanisch

Dynamic



# Charles



Il bordo a contrasto della testiera e del giroletto di Charles danno una personalità ferma e decisa, rendendo questo letto il protagonista della tua camera con il suo disegno semplice e distinto.

The contrasting trim on the headboard and bed frame of Charles give it a strong, decisive personality, making this bed with its simple, distinctive design the focal point of your bedroom.

Le bord en contraste de la tête et du cadre de lit de Charles donnent un caractère ferme et résolu et en font le protagoniste de votre chambre à coucher par son dessin simple et distingué.

Die farblich abgesetzte Bordüre des Kopfteils und Bettrahmens von Charles zeugen von einem festen und entschlossenen Charakter und machen dieses Bett mit seinem schlichten und feinen Design zum Star Ihres Schlafzimmers.











Le linee minimaliste giocano con il bordo a contrasto che rende più solido ed evidente il giroletto.

The minimalist lines have a contrasting edge that makes the bed frame look more solid and evident.

Les lignes minimalistes jouent avec le bord en contraste qui rend plus solide et évident le tour de lit.

Die minimalistische Linienführung spielt mit der farblich abgesetzten Bordüre, die den Bettrahmen solider macht und sichtlich unterstreicht.



# Charles

COMPLETAMENTE SFODERABILE / COMPLETELY REMOVABLE FABRIC / COMPLÈTEMENT DÉHOUSSABLE / VOLLSTÄNDIG ABZIEHBAR

**MASSELLI** in legno di abete e/o scatolati in multistrato di legno di pioppo.

**PANNELLI** da 18/25 mm in particelle di legno di pioppo in classe E1 a bassa emissione di formaldeide e fibra di legno naturale.

**ESPANSI** di poliuretano indeformabile a portanza differenziata, densità da 18 kg/mc a 40 kg/mc.

**PRIMO RIVESTIMENTO** in espanso di poliestere accoppiato a caldo a vellutino aggrappante in poliestere e/o ovatta di poliestere al 100% da 200gr.

**PANNELLI FONDO** contenitore da 12-14 mm in particelle di legno di pioppo in classe E1.

**FORGINGS** fir wood, and/or boxed in poplar plywood.

**PANELS** 18/25 mm in poplar wood particles class E1 low formaldehyde emission and natural wood fiber.

**POLYURETHANE FOAM**, crushproof, of different capacity, density from 18 kg/mc to 40 kg/mc.

**FIRST COATING** hot bonded polyester foam, velvet adhesion in polyester and/or 100% polyester wool, 200gr.

**CONTAINER BOTTOM** panels 12-14 mm in poplar wood particles class E1.

**TIGE** en pin et/ou boitiers en multicouche en bois de peuplier

**PANNEAUX** de 18/25 mm en particules de bois de peuplier classe E1 à faible émission de formaldéhyde et fibre de bois naturelle.

**POLYURÉTHANE EXPANSÉ** indéformable à portée différenciée, densité de 18kg/m<sup>3</sup> à 40kg/m<sup>3</sup>.

**PREMIER REVÊTEMENT** en polyester expansé accouplé à chaud à un velours accrochant en polyester et/ou ouate de polyester à 100% de 200g.

**PANNEAUX DE FOND COFFRE** rangement de 12-14mm en particules de bois de peuplier classe E1

**MASSIVES** Tannenholz und/oder Blöcke aus Pappelmehrschichtholz.

**SPANPLATTEN** aus Pappelholz mit 18/25 mm Schichtdicke der Klasse E1, geringer Formaldehydabgabe und natürlichen Holzfasern.

**POLYURETHANSCHAUM**, nicht verformbar und mit differenzierter Tragfähigkeit, Dichten von 18 kg/m<sup>3</sup> bis 40 kg/m<sup>3</sup>.

**ERSTER ÜBERZUG** aus Polyesterschaum, der auf Polyester-Samt und/oder 100% Polyesterwatte (zu 200 g) heiß aufkaschiert wurde.

**BODENPLATTEN** des Bettkastens aus 12-14 mm starken Spanplatten aus Pappelholz der Klasse E1.



## Optional

Rete / Support / Sommier / Lattenrost Pag 548

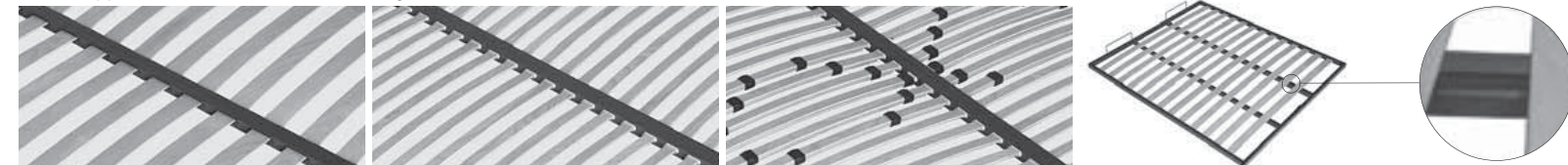

**Armony** (Standard)

**Thai**  
46 doghe  
46 slats  
46 attes  
46 Leisten

**Energy**  
Non applicabile a rete da 120 cm  
Not applicable to 120 cm support  
Non applicable au sommier de 120 cm  
Gilt nicht für Lattenrost zu 120 cm

**Doppio Flip**  
Solo 140/160x190/200 - 180x200  
Only 140/160x190/200 - 180x200  
Uniquement 140/160x190/200 - 180x200  
Nur 140/160x190/200 - 180x200

Pag 552



**Sacco contenitore multiuso**  
Multipurpose storage bag  
Sac coffre de rangement multi usage  
Mehrzweck-Aufbewahrungstasche

Pag 553



**Tessuto coprirete traspirante antipolvere**  
Support cover fabric breathable and dustproof  
Tissu couvre-sommier transpirant anti-poussière  
Atmungsaktives, vor Staub schützendes Gewebe

Pag 557



**Regolatore altezza rete solo per reti in appoggio**  
Support height adjuster only for resting frames  
Réglage hauteur sommier uniquement pour sommiers à poser  
Lattenrost-Höhenverstellung nur für aufliegende Lattenroste

Pag 556



**Clean Up System**

## RING SMART

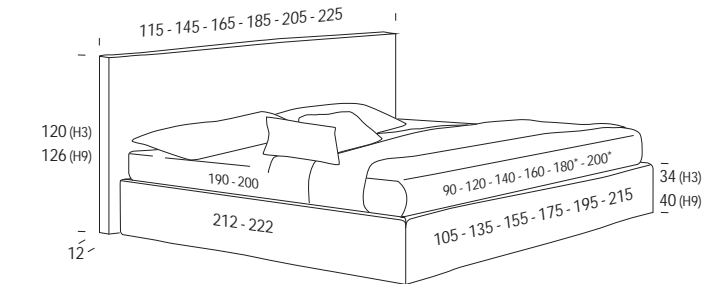

\* Rete L. 180 e L. 200 cm solo profondità 200 cm / Support W. 180 and W. 200 cm only D 200 cm / Sommier L. 180 et L. 200 cm uniquement en profondeur 200 cm / Attenrost B. 180 und B. 200 cm nur mit Tiefe 200 cm

Standard **BASIC H 3**



Wengé / Wengé  
/ Argent / Silber



Argento / Silver  
/ Argent / Silber

Pag 545



Nero / Black  
/ Noir / Schwarz



Bianco / White  
/ Blanc / Weiß

Optional **LUX H 3**



Wengé / Wengé  
/ Wengé / Wengé



Cromo / Chrome  
/ Chrome / Chrom

Pag 545



Nero / Black  
/ Noir / Schwarz



Bianco / White  
/ Blanc / Weiß

Optional **VISUAL H 9**



Wengé / Wengé  
/ Wengé / Wengé



Argento / Silver  
/ Argent / Silber

Pag 545



Nero / Black  
/ Noir / Schwarz



Bianco / White  
/ Blanc / Weiß

## Optional Pag 550

Meccanica / Mechanism  
/ Mécanique / Mechanisch

Dynamic



Maverick

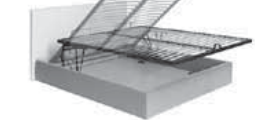

## RING YORK

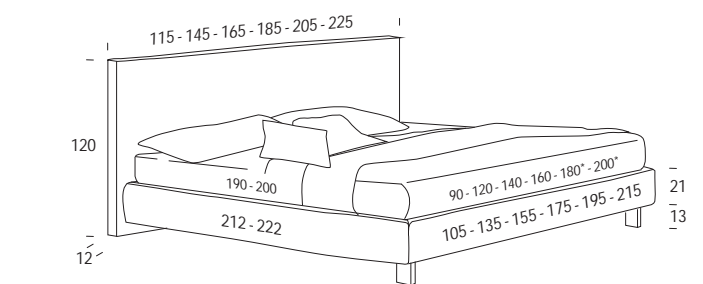

\* Rete L. 180 e L. 200 cm solo profondità 200 cm / Support W. 180 and W. 200 cm only D 200 cm / Sommier L. 180 et L. 200 cm uniquement en profondeur 200 cm / Attenrost B. 180 und B. 200 cm nur mit Tiefe 200 cm

Standard **BLADE H 13**



Satinato / Satin  
/ Satiné / Satiniert

Pag 546



Bronzato / Bronze  
/ Bronze / Bronziert

Optional **TOWER H 13**



Optional **PLEXY H 13**



Pag 546

## Optional Pag 550

Meccanica / Mechanism  
/ Mécanique / Mechanisch

Dynamic



# Rick



Forme semplici e lineari, con qualche rimando alla storia del design moderno. Il tutto sapientemente misurato per un letto di gusto minimal grazie alla leggerezza del tratto, ma di forte personalità data dall'equilibrio delle linee e dei volumi.

Simple and linear shapes, with some references to the history of modern design. The all thing skilfully measured for a bed with a minimal style due to a light stretch but with a balance of lines and volumes giving a strong character.

Formes simples et linéaires, avec quelque rappel à l'histoire du design moderne. Le tout habilement calculé pour un lit au goût minimal grâce à la légèreté du trait, mais avec une forte personnalité donnée par des lignes et des volumes équilibrés.

Schlichte und lineare Formen, mit einigen Verweisen auf den Werdegang des modernen Designs. Alles klug für ein Bett zusammengestellt, das dank der leichten Linienführung minimalistisch wirkt, aber durch das Gleichgewicht der Konturen und der Volumina eine starke Persönlichkeit ausstrahlt.

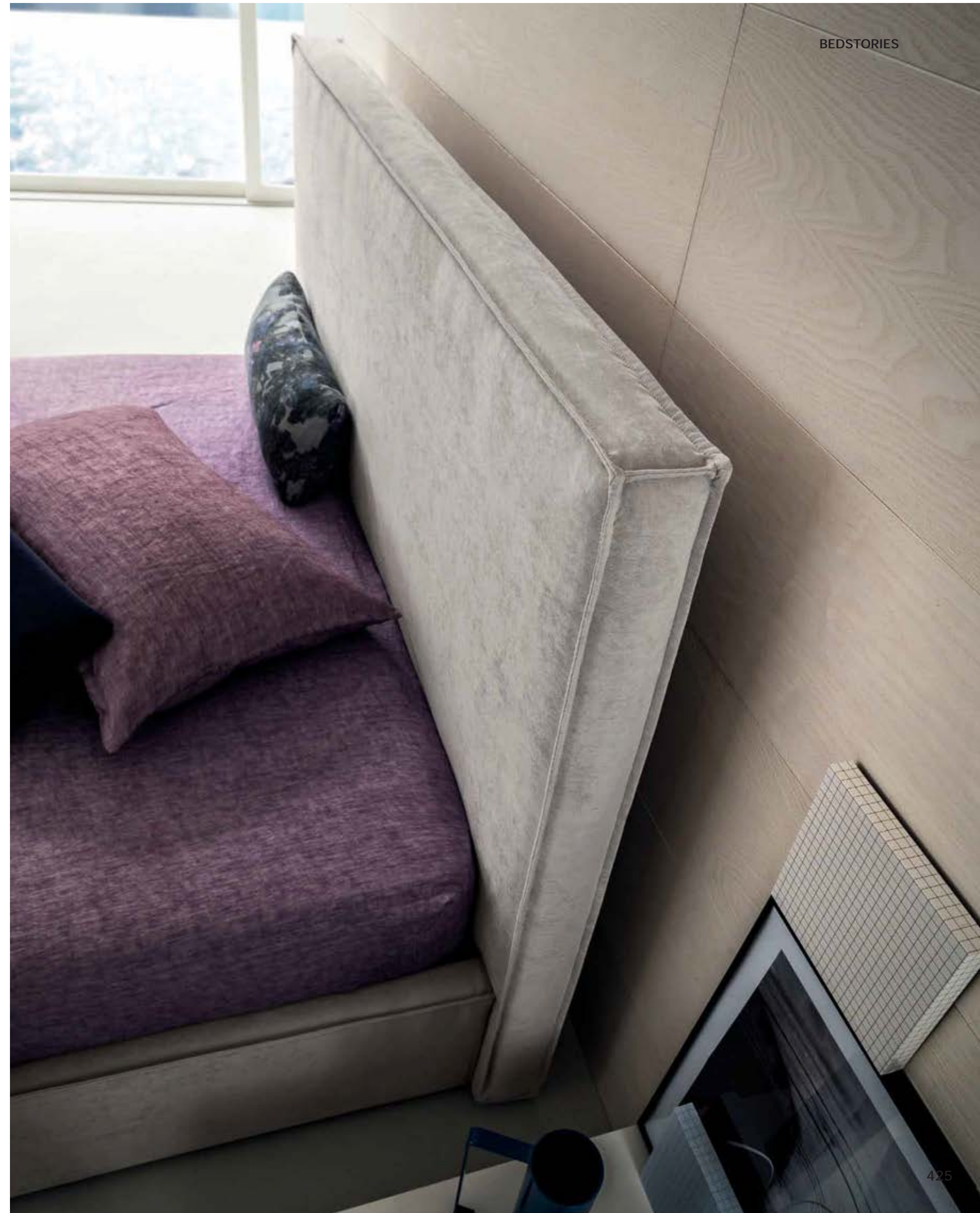





Rigorous e lineare, minimalismo morbido...  
Il disegno squadrato è segnato dal bordo pizzicato che delinea perfettamente i profili della testiera e del giroletto. Donando eleganza e comfort.

Rigorous and linear, soft minimalism...  
The square design is marked by the pinched edge that perfectly outlines the profiles of the headboard and bed frame. Giving it elegance and comfort.

Rigoureuse et linéaire, minimalisme moelleux...  
Le dessin carré est marqué par un bord pincé qui limite parfaitement les profils de la tête de lit et du tour de lit. Et donne élégance et confort.

Streng und linear, weicher Minimalismus...  
Das quadratische Design zeichnet sich durch die Kante in Pinched-Optik aus, die die Profile des Kopfteils und des Bettrahmens perfekt umreißt. Sie sorgt für Eleganz und Komfort.







# Rick

COMPLETAMENTE SFODERABILE / COMPLETELY REMOVABLE FABRIC / COMPLÈTEMENT DÉHOUSSABLE / VOLLSTÄNDIG ABZIEHBAR

**MASSELLI** in legno di abete e/o scatolati in multistrato di legno di pioppo.

**PANNELLI** da 18/25 mm in particelle di legno di pioppo in classe E1 a bassa emissione di formaldeide e fibra di legno naturale.

**ESPANSI** di poliuretano indeformabile a portanza differenziata, densità da 18 kg/mc a 40 kg/mc.

**PRIMO RIVESTIMENTO** in espanso di poliestere accoppiato a caldo a vellutino aggrappante in poliestere e/o ovatta di poliestere al 100% da 200gr.

**PANNELLI FONDO** contenitore da 12-14 mm in particelle di legno di pioppo in classe E1.

**FORGINGS** fir wood, and/or boxed in poplar plywood.

**PANELS** 18/25 mm in poplar wood particles class E1 low formaldehyde emission and natural wood fiber.

**POLYURETHANE FOAM**,

crushproof, of different capacity,

density from 18 kg/mc to 40 kg/mc.

**FIRST COATING** hot bonded

polyester foam, velvet adhesion in

polyester and/or 100% polyester

wool, 200gr.

**CONTAINER BOTTOM** panels

12-14 mm in poplar wood particles

class E1.

**TIGE** en pin et/ou boitiers en multicouche en bois de peuplier

**PANNEAUX** de 18/25 mm en particules de bois de peuplier classe E1 à faible émission de

formaldéhyde et fibre de bois naturelle.

**POLYURÉTHANE EXPANSÉ**

indéformable à portée différenciée,

densité de 18kg/m<sup>3</sup> à 40kg/m<sup>3</sup>.

**PREMIER REVÊTEMENT** en

polyester expansé accouplé à

chaud à un velours accrochant en

polyester et/ou ouate de polyester

à 100% de 200g.

**PANNEAUX DE FOND COFFRE**

rangement de 12-14mm en

particules de bois de peuplier

classe E1

**MASSIVES** Tannenholz und/oder Blöcke aus Pappelmehrschichtholz.

**SPANPLATTEN** aus Pappelholz mit 18/25 mm Schichtdicke der Klasse E1, geringer Formaldehydabgabe und natürlichen Holzfasern.

**POLYURETHANSCHAUM**, nicht verformbar und mit differenzierter

Tragfähigkeit, Dichten von 18 kg/m<sup>3</sup>

bis 40 kg/m<sup>3</sup>.

**ERSTER ÜBERZUG** aus

Polyesterschaum, der auf

Polyester-Samt und/oder 100%

Polyesterwatte (zu 200 g) heiß

aufkaschiert wurde.

**BODENPLATTEN** des Bettkastens

aus 12-14 mm starken Spanplatten

aus Pappelholz der Klasse E1.



## RING SMART

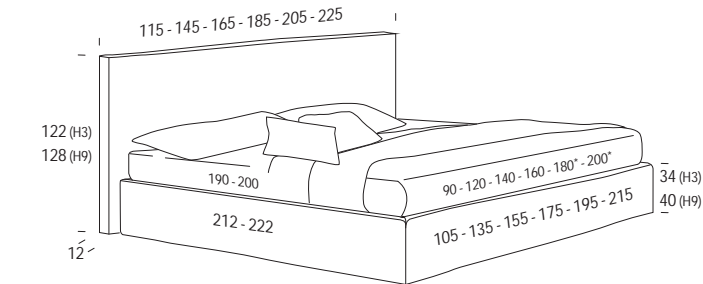

\* Rete L. 180 e L. 200 cm solo profondità 200 cm / Support W. 180 and W. 200 cm only D 200 cm / Sommier L. 180 et L. 200 cm uniquement en profondeur 200 cm / Attenrost B. 180 und B. 200 cm nur mit Tiefe 200 cm

Standard **BASIC H 3**

Pag 545

Optional **LUX H 3**

Pag 545

Optional **VISUAL H 9**

Pag 545



Wengé / Wengé / Wengé / Wengé

Nero / Black / Noir / Schwarz



Wengé / Wengé / Wengé / Wengé

Nero / Black / Noir / Schwarz



Wengé / Wengé / Wengé / Wengé

Nero / Black / Noir / Schwarz

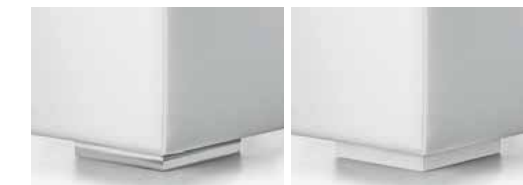

Argento / Silver / Argent / Silber

Bianco / White / Blanc / Weiß



Cromo / Chrome / Chrom / Chrom

Bianco / White / Blanc / Weiß



Argento / Silver / Argent / Silber

Bianco / White / Blanc / Weiß

## Optional

Rete / Support / Sommier / Lattenrost Pag 548

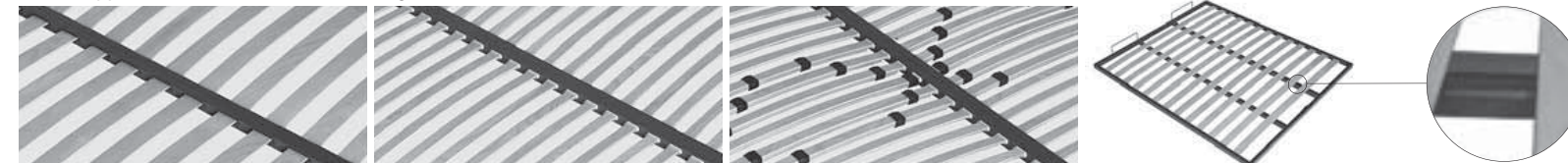

**Armony** (Standard)

**Thai**

46 doghe  
46 slats  
46 attes  
46 Leisten

**Energy**

Non applicabile a rete da 120 cm  
Not applicable to 120 cm support  
Non applicable au sommier de 120 cm  
Gilt nicht für Lattenrost zu 120 cm

**Doppio Flip**

Solo 140/160x190/200 - 180x200  
Only 140/160x190/200 - 180x200  
Uniquement 140/160x190/200 - 180x200  
Nur 140/160x190/200 - 180x200

Pag 552



**Sacco contenitore multiuso**  
Multipurpose storage bag  
Sac coffre de rangement multi usage  
Mehrzweck-Aufbewahrungstasche

Pag 553



**Tessuto coprirete traspirante antipolvere**  
Support cover fabric breathable and dustproof  
Tissu couvre-sommier transpirant anti-poussière  
Atmungsaktives, vor Staub schützendes Gewebe

Pag 557



**Regolatore altezza rete solo per reti in appoggio**  
Support height adjuster only for resting frames  
Réglage hauteur sommier uniquement pour sommiers à poser  
Lattenrost-Höhenverstellung nur für aufliegende Lattenroste

Pag 556



**Clean Up System**

# Miller



Il ring di Miller con il piedino in plexiglass trasparente, alza da terra il letto, slanciandolo. Il ring a terra, invece, rende una sensazione di pulizia, mentre le cuciture in rilievo a vista tracciano le linee eleganti e accurate del letto.

The Miller bed frame with transparent Plexiglass feet raises the bed from the ground, giving it a lighter look down. The low bed frame instead gives a clean feel while the visible relief stitching outlines the meticulous, elegant contours of the bed.

Le tour de lit de Miller avec les pieds en plexiglas transparent, soulève le lit du sol et l'élance. Au contraire, le tour de lit au sol donne une sensation de propreté et les coutures visibles en relief tracent les lignes du lit élégantes et soignées.

Das Gestell von Miller lässt das Bett mit seinem transparenten Plexiglasfuß vom Boden abheben und schlanker erscheinen. Das auf dem Boden ruhende Gestell sorgt für ein sauberes Finish, während die hervorstehenden Nähte die elegante und sorgfältige Linienführung betonen.









Il ring alto con cuciture a vista in rilievo con pizzicatura sugli angoli e sul bordo superiore del giroletto. Più lineare, essenziale e pulita la versione con il ring basso.

The high ring with stitching in relief and pinching work on the corners and top edge of the bed frame. More linear, basic and clean, the version with the low ring.

Le tour de lit haut avec couture visibles en relief et pincées sur les angles et sur le bord supérieur du tour de lit. La version tour de lit bas est plus linéaire et essentielle.

Das hohe Gestell mit sichtbaren Nähten und Pinch-Optik an den Ecken und an der Bettrahmen-Oberkante. Linearer, schlichter und sauberer die Ausführung mit niedrigem Gestell.



# Miller

COMPLETAMENTE SFODERABILE / COMPLETELY REMOVABLE FABRIC / COMPLÈTEMENT DÉHOUSSABLE / VOLLSTÄNDIG ABZIEHBAR

**MASSELLI** in legno di abete e/o scatolati in multistrato di legno di pioppo.

**PANNELLI** da 18/25 mm in particelle di legno di pioppo in classe E1 a bassa emissione di formaldeide e fibra di legno naturale.

**ESPANSI** di poliuretano indeformabile a portanza differenziata, densità da 18 kg/mc a 40 kg/mc.

**PRIMO RIVESTIMENTO** in espanso di poliestere accoppiato a caldo a vellutino aggrappante in poliestere e/o ovatta di poliestere al 100% da 200gr.

**PANNELLI FONDO** contenitore da 12-14 mm in particelle di legno di pioppo in classe E1.

**FORGINGS** fir wood, and/or boxed in poplar plywood.

**PANELS** 18/25 mm in poplar wood particles class E1 low formaldehyde emission and natural wood fiber.

**POLYURETHANE FOAM**, crushproof, of different capacity, density from 18 kg/mc to 40 kg/mc.

**FIRST COATING** hot bonded polyester foam, velvet adhesion in polyester and/or 100% polyester wool, 200gr.

**CONTAINER BOTTOM** panels 12-14 mm in poplar wood particles class E1.

**TIGE** en pin et/ou boitiers en multicouche en bois de peuplier

**PANNEAUX** de 18/25 mm en particules de bois de peuplier classe E1 à faible émission de formaldéhyde et fibre de bois naturelle.

**POLYURÉTHANE EXPANSÉ** indéformable à portée différenciée, densité de 18kg/m<sup>3</sup> à 40kg/m<sup>3</sup>.

**PREMIER REVÊTEMENT** en polyester expansé accouplé à chaud à un velours accrochant en polyester et/ou ouate de polyester à 100% de 200g.

**PANNEAUX DE FOND COFFRE** rangement de 12-14mm en particules de bois de peuplier classe E1

**MASSIVES** Tannenholz und/oder Blöcke aus Pappelmehrschichtholz.

**SPANPLATTEN** aus Pappelholz mit 18/25 mm Schichtdicke der Klasse E1, geringer Formaldehydabgabe und natürlichen Holzfasern.

**POLYURETHANSCHAUM**, nicht verformbar und mit differenzierter Tragfähigkeit, Dichten von 18 kg/m<sup>3</sup> bis 40 kg/m<sup>3</sup>.

**ERSTER ÜBERZUG** aus Polyesterschaum, der auf Polyester-Samt und/oder 100% Polyesterwatte (zu 200 g) heiß aufkaschiert wurde.

**BODENPLATTEN** des Bettkastens aus 12-14 mm starken Spanplatten aus Pappelholz der Klasse E1.



## Optional

Rete / Support / Sommier / Lattenrost Pag 548

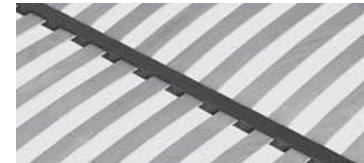

**Armony**  
(Standard)

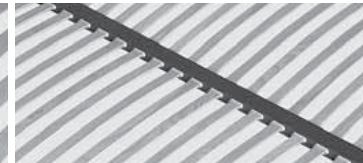

**Thai**  
46 doghe  
46 slats  
46 attes  
46 Leisten

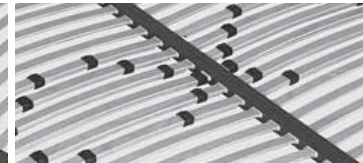

**Energy**  
Non applicabile a rete da 120 cm  
Not applicable to 120 cm support  
Non applicable au sommier de 120 cm  
Gilt nicht für Lattenrost zu 120 cm

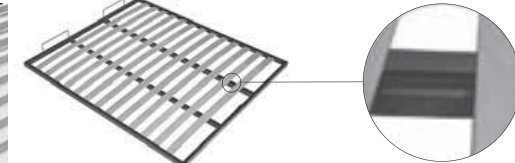

**Doppio Flip**  
Solo 140/160x190/200 - 180x200  
Only 140/160x190/200 - 180x200  
Uniquement 140/160x190/200 - 180x200  
Nur 140/160x190/200 - 180x200

Pag 552



**Sacco contenitore multiuso**  
Multipurpose storage bag  
Sac coffre de rangement multi usage  
Mehrzweck-Aufbewahrungstasche

Pag 553



**Tessuto coprirete traspirante antipolvere**  
Support cover fabric breathable and dustproof  
Tissu couvre-sommier transpirant anti-poussière  
Atmungsaktives, vor Staub schützendes Gewebe

Pag 557



**Regolatore altezza rete solo per reti in appoggio**  
Support height adjuster only for resting frames  
Réglage hauteur sommier uniquement pour sommiers à poser  
Lattenrost-Höhenverstellung nur für aufliegende Lattenroste

Pag 556



**Clean Up System**

## RING SMART

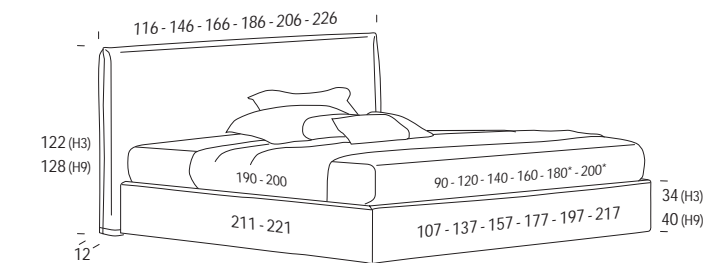

\* Rete L. 180 e L. 200 cm solo profondità 200 cm / Support W. 180 and W. 200 cm only D 200 cm  
/ Sommier L. 180 et L. 200 cm uniquement en profondeur 200 cm / Attenrost B. 180 und B. 200 cm nur mit Tiefe 200 cm

Standard **BASIC H 3**



Wengé / Wengé  
/ Argent / Silber

Pag 545



Nero / Black  
/ Noir / Schwarz

Optional **LUX H 3**



Wengé / Wengé  
/ Wengé / Wengé

Pag 545



Nero / Black  
/ Noir / Schwarz

Optional **VISUAL H 9**



Wengé / Wengé  
/ Wengé / Wengé

Pag 545



Nero / Black  
/ Noir / Schwarz



Argento / Silver  
/ Argent / Silber



Bianco / White  
/ Blanc / Weiß



Cromo / Chrome  
/ Chrome / Chrom



Bianco / White  
/ Blanc / Weiß



Argento / Silver  
/ Argent / Silber



Bianco / White  
/ Blanc / Weiß

## Optional Pag 550

Meccanica / Mechanism  
/ Mécanique / Mechanisch

Dynamic



Maverick

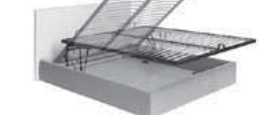

## RING YORK

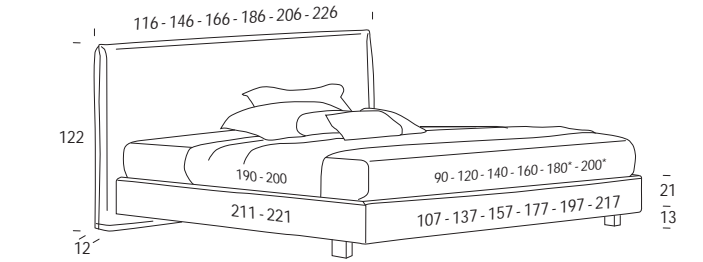

\* Rete L. 180 e L. 200 cm solo profondità 200 cm / Support W. 180 and W. 200 cm only D 200 cm  
/ Sommier L. 180 et L. 200 cm uniquement en profondeur 200 cm / Attenrost B. 180 und B. 200 cm nur mit Tiefe 200 cm

Standard **BLADE H 13**



Satinato / Satin  
/ Satiné / Satiniert

Pag 546



Bronzato / Bronze  
/ Bronze / Bronziert

Optional **TOWER H 13**



Optional **PLEXY H 13**



Pag 546

## Optional Pag 550

Meccanica / Mechanism  
/ Mécanique / Mechanisch

Dynamic



# Classic Collection

Un'idea romantica di letto che affonda le sue radici in linee dal gusto retrò, riadattate ai giorni nostri. Un classico contemporaneo elegante, versatile, capace di impreziosire qualsiasi ambiente con un tocco di estro. Classic Collection si distingue per l'armonia dei volumi, caratterizzati dalle forme sinuose e raffinate delle importanti testiere.

A romantic idea of bed rooted in retro style lines adapted to present-day. A contemporary classic, stylish, versatile, enriching any room with a hint of inspiration. Classic Collection features the harmony of volumes defined by the sinuous and elegant shapes of the imposing headboards.

Une idée romantique du lit qui fonde ses racines sur des lignes rétro, revisitées aux jours d'aujourd'hui. Un contemporain élégant classique, versatile, capable d'enrichir quelconque milieu avec une touche de créativité. Classic Collection se distingue par l'harmonie de ses volumes, caractérisés par les formes sinueuses et raffinées de ses têtes de lits importantes.

Eine romantische Vorstellung von einem Bett, dessen Linienführung Retro-angehaucht ist, aber dem heutigen Geschmack angepasst wurde. Ein zeitgemäßer Klassiker, der elegant und vielseitig ist und jedes Ambiente mit einem Touch Phantasie aufwertet. Die Classic Collection besticht durch harmonische Volumina, die sich durch geschwungene, raffinierte Formen und beachtliche Kopfteile auszeichnen.



# Vern



Vern si è fermato in un mondo parallelo dove il tempo non passa: le sue forme e le sue linee sono intramontabili.

Vern is suspended in a parallel universe where time stands still: its shapes and lines are timeless.

Vern est resté en suspend dans un monde parallèle où le temps ne passe pas: ses formes et ses lignes sont indémodables.

Vern ist in einer Parallelwelt stehen geblieben, in der die Zeit nicht vergeht: Seine Formen und Linien sind zeitlos.







Il particolare prezioso della gonnella a volant. Questa lavorazione sartoriale muove la superficie molto minimal di Vern.

The precious detail of the skirt with frills. This kind of processing moves the very minimal surface of Vern.

Le précieux détail de la jupe à volant. Cette réalisation haute couture crée un mouvement minimaliste au modèle Vern.

Das kostbare Detail des umlaufenden Volants. Dieses vom Schneider angefertigte Detail bringt Bewegung in Verns sehr minimalistische Oberfläche.

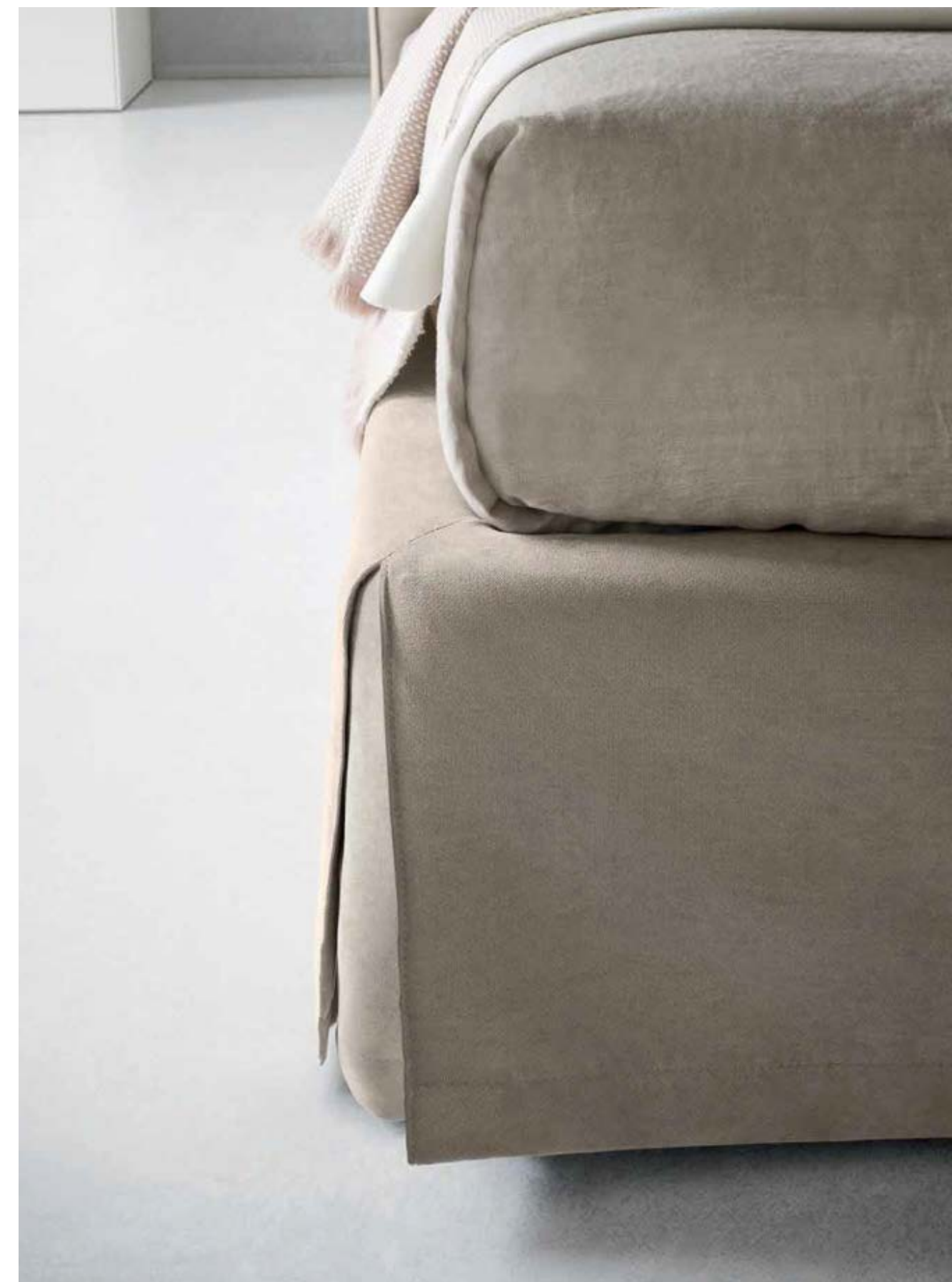

# Vern

COMPLETAMENTE SFODERABILE / COMPLETELY REMOVABLE FABRIC / COMPLÈTEMENT DÉHOUSSABLE / VOLLSTÄNDIG ABZIEHBAR

**MASSELLI** in legno di abete e/o scatolati in multistrato di legno di pioppo.

**PANNELLI** da 18/25 mm in particelle di legno di pioppo in classe E1 a bassa emissione di formaldeide e fibra di legno naturale.

**ESPANSI** di poliuretano indeformabile a portanza differenziata, densità da 18 kg/mc a 40 kg/mc.

**PRIMO RIVESTIMENTO** in espanso di poliestere accoppiato a caldo a vellutino aggrappante in poliestere e/o ovatta di poliestere al 100% da 200gr.

**PANNELLI FONDO** contenitore da 12-14 mm in particelle di legno di pioppo in classe E1.

**FORGINGS** fir wood, and/or boxed in poplar plywood.

**PANELS** 18/25 mm in poplar wood particles class E1 low formaldehyde emission and natural wood fiber.

**POLYURETHANE FOAM** crushproof, of different capacity, density from 18 kg/mc to 40 kg/mc.

**FIRST COATING** hot bonded polyester foam, velvet adhesion in polyester and/or 100% polyester wool, 200gr.

**CONTAINER BOTTOM** panels 12-14 mm in poplar wood particles class E1.

**TIGE** en pin et/ou boitiers en multicouche en bois de peuplier.

**PANNEAUX** de 18/25 mm en particules de bois de peuplier classe E1 à faible émission de formaldéhyde et fibre de bois naturelle.

**POLYURÉTHANE EXPANSÉ** indéformable à portée différenciée, densité de 18kg/m<sup>3</sup> à 40kg/m<sup>3</sup>.

**PREMIER REVÊTEMENT** en polyester expansé accouplé à chaud à un velours accrochant en polyester et/ou ouate de polyester à 100% de 200g.

**PANNEAUX DE FOND COFFRE** rangement de 12-14mm en particules de bois de peuplier classe E1.

**MASSIVES** Tannenholz und/oder Blöcke aus Pappelmehrschichtholz.

**SPANPLATTEN** aus Pappelholz mit 18/25 mm Schichtdicke der Klasse E1, geringer Formaldehydabgabe und natürlichen Holzfasern.

**POLYURETHANSCHAUM**, nicht verformbar und mit differenzierter Tragfähigkeit, Dichten von 18 kg/m<sup>3</sup> bis 40 kg/m<sup>3</sup>.

**ERSTER ÜBERZUG** aus Polyesterschaum, der auf Polyester-Samt und/oder 100% Polyesterwatte (zu 200 g) heiß aufkaschiert wurde.

**BODENPLATTEN** des Bettkastens aus 12-14 mm starken Spanplatten aus Pappelholz der Klasse E1.



## RING SMART



## RING VENICE



**Gonna in tinta**  
Skirt in matching colour  
Jupe en teinte  
Ton-in-Ton ausgeführter Volant

**Gonna a contrasto**  
Skirt contrasting  
Jupe en contraste  
Farblich abgesetzter Volant

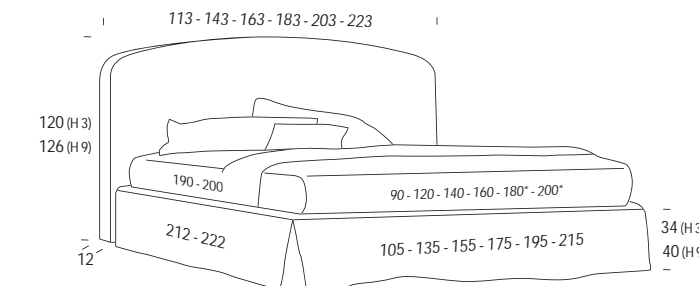

\* Rete L. 180 e L. 200 cm solo profondità 200 cm / Support W. 180 and W. 200 cm only D 200 cm  
/ Sommier L. 180 et L. 200 cm uniquement en profondeur 200 cm / Attenrost B. 180 und B. 200 cm nur mit Tiefe 200 cm

### Optional Pag 550

Meccanica / Mechanism  
/ Mécanique / Mechanisch

Dynamic

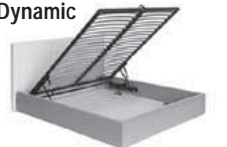

Maverick

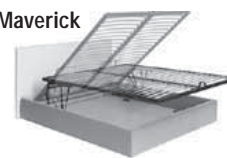

### Optional

Rete / Support / Sommier / Lattenrost Pag 548

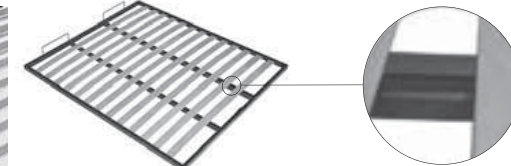
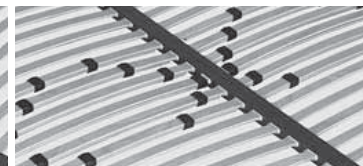
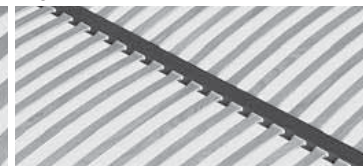
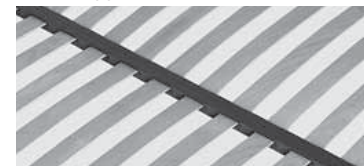

**Armony**  
(Standard)

**Thai**  
46 doghe  
46 slats  
46attes  
46 Leisten

**Energy**  
Non applicabile a rete da 120 cm  
Not applicable to 120 cm support  
Non applicable au sommier de 120 cm  
Gilt nicht für Lattenrost zu 120 cm

**Doppio Flip**  
Solo 140/160x190/200 - 180x200  
Only 140/160x190/200 - 180x200  
Uniquement 140/160x190/200 - 180x200  
Nur 140/160x190/200 - 180x200

Pag 552



Pag 553



Pag 557



Pag 556



**Sacco contenitore multiuso**  
Multipurpose storage bag  
Sac coffre de rangement multi usage  
Mehrzweck-Aufbewahrungstasche

**Tessuto coprirete traspirante antipolvere**  
Support cover fabric breathable and dustproof  
Tissu couvre-sommier respirant anti-poussière  
Atmungsaktives, vor Staub schützendes Gewebe

**Regolatore altezza rete solo per reti in appoggio**  
Support height adjuster only for resting frames  
Réglage hauteur sommier uniquement pour sommiers à poser  
Lattenrost-Höhenverstellung nur für aufliegende Lattenroste

**Clean Up System**

# Oscar

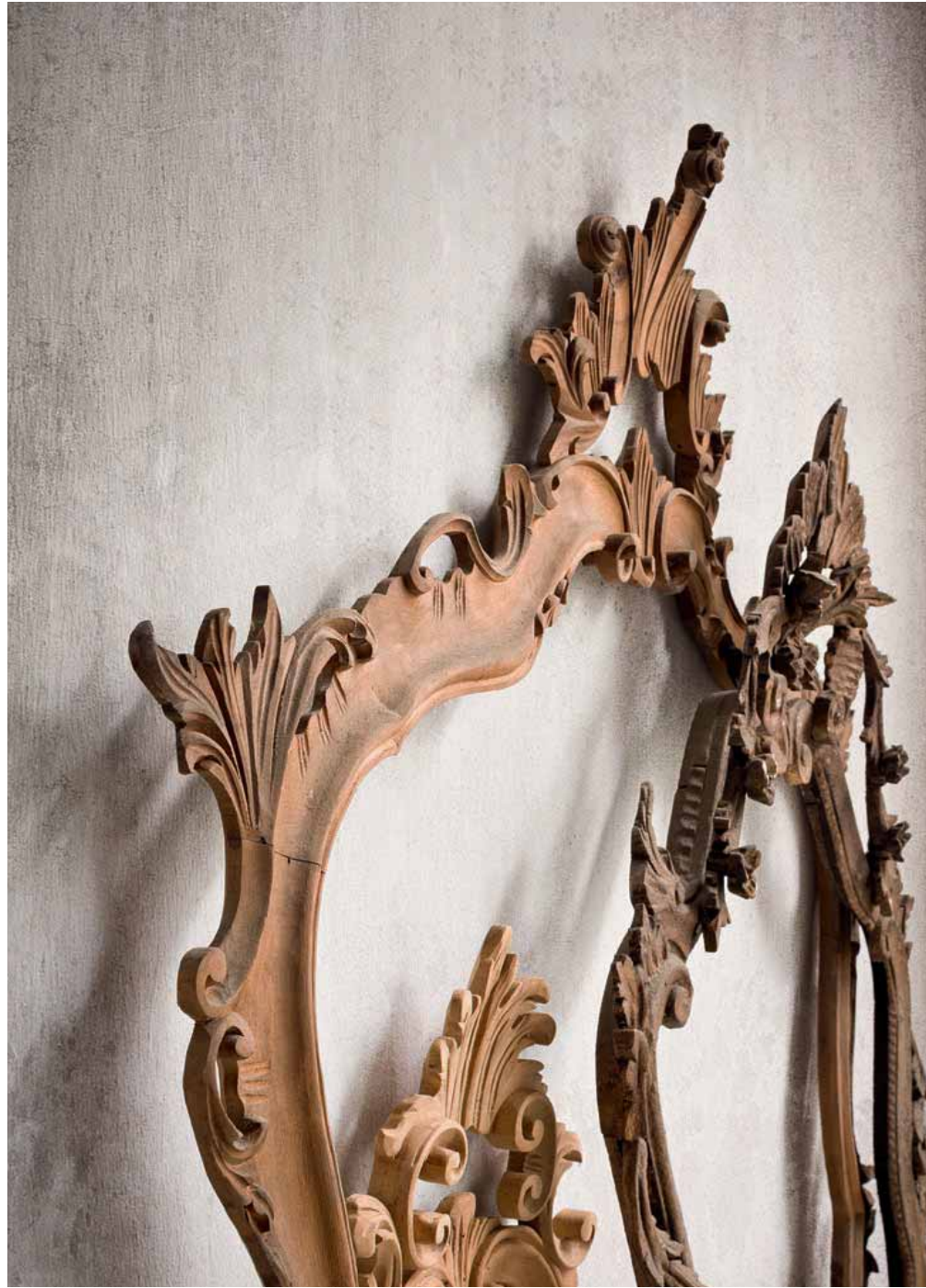

Una cornice unica, ma la possibilità di cambiare il pannello: in questo modo Oscar potrà cambiare la sua personalità in base al tuo umore.

A single frame but the option to change the panel. So Oscar can change personality to suit your mood.

Un cadre unique, mais l'opportunité de changer le panneau: ainsi Oscar pourra changer son caractère en fonction de votre humeur.

Ein einzigartiger Rahmen, der aber die Möglichkeit bietet, das Paneel zu wechseln: auf diese Weise kann Oscar seine Persönlichkeit nach Lust und Laune verändern.



BEDSTORIES





Le linee essenziali citano forme al di là del tempo. La cornice diventa un importante elemento a sé, che caratterizza la testiera scelta.

The essentials lines refer to forms beyond time. The frame becomes an important element in itself that characterizes the chosen headboard.

Lignes essentielles hors du temps. Le cadre devient un élément important qui caractérise la tête de lit choisie.

Die schlichten Linien erinnern an zeitlose Formen. Der Rahmen wird zu einem wichtigen, eigenständigen Element, das das gewählte Kopfteil charakterisiert.



Una cornice unica...  
la possibilità di testiere diverse sia  
nel colore (della cornice) sia nella  
lavorazione. Dalla più semplice e  
liscia (1) a quelle effetto capitonné  
senza bottone (2) o con bottone  
in tinta (3) o a contrasto (4). Anche  
con bottoni Swarovski Kristal  
(5) o nero (6) per una proposta  
articolata.

A unique frame...  
the possibility of different  
headboards, both in the color (of  
the frame) and in the processing.  
From the most simple and smooth  
(1) to those with a quilted effect  
without buttons (2) or with matching  
(3) or contrasting button (4). Also  
with Swarovski Kristal (5) or black  
(6) buttons for a detailed proposal.



1. Liscio / Smooth / Lisse / Glatt



2. Nuvola / Cloud / Nuage / Wolke



3. Bottone / Buttons / Bouton / Knopf

Un cadre unique...  
choix de têtes de lit différentes  
pour la couleur (du cadre) et pour  
la réalisation. De la plus simple et  
lisse (1) à celle capitonnée sans  
boutons (2) ou avec bouton de la  
même couleur (3) ou de couleur  
différente pour créer un contraste.  
(4) Disponible avec boutons  
Swarovski Kristal (5) ou noir (6) pour  
une version structurée.

Ein einzigartiger Rahmen...  
der mit Kopfteilen erhältlich ist, die  
sich in Farbe (des Rahmens) und  
in der Ausführung unterscheiden.  
Von schlichten und glatten  
Ausführungen (1) bis hin zu  
Capitonné-Verarbeitungen ohne  
Knopf (2) oder mit gleichfarbigem  
(3) bzw. farblich abgesetztem Knopf  
(4). Auch mit Swarovski-Knöpfen in  
Transparent (5) oder Schwarz (6) für  
eine ganz besondere Variante.



4. Bottoni a contrasto / Contrasting buttons / Bouton couleur différente / Farblich abgesetzter Knopf



5. Swarovski bianco / white Swarovski / Swarovski blanc / Swarovski Weiß



6. Swarovski Nero / black Swarovski / Swarovski noir / Swarovski Schwarz



# Oscar

COMPLETAMENTE SFODERABILE / COMPLETELY REMOVABLE FABRIC / COMPLÈTEMENT DÉHOUSSABLE / VOLLSTÄNDIG ABZIEHBAR

**MASSELLI** in legno di abete e/o scatolati in multistrato di legno di pioppo.

**PANNELLI** da 18/25 mm in particelle di legno di pioppo in classe E1 a bassa emissione di formaldeide e fibra di legno naturale.

**ESPANSI** di poliuretano indeformabile a portanza differenziata, densità da 18 kg/mc a 40 kg/mc.

**PRIMO RIVESTIMENTO** in espanso di poliestere accoppiato a caldo a vellutino aggrappante in poliestere e/o ovatta di poliestere al 100% da 200gr.

**PANNELLI FONDO** contenitore da 12-14 mm in particelle di legno di pioppo in classe E1.

**FORGINGS** fir wood, and/or boxed in poplar plywood.

**PANELS** 18/25 mm in poplar wood particles class E1 low formaldehyde emission and natural wood fiber.

**POLYURETHANE FOAM**, crushproof, of different capacity, density from 18 kg/mc to 40 kg/mc.

**FIRST COATING** hot bonded polyester foam, velvet adhesion in polyester and/or 100% polyester wool, 200gr.

**CONTAINER BOTTOM** panels 12-14 mm in poplar wood particles class E1.

**TIGE** en pin et/ou boitiers en multicouche en bois de peuplier

**PANNEAUX** de 18/25 mm en particules de bois de peuplier classe E1 à faible émission de formaldéhyde et fibre de bois naturelle.

**POLYURÉTHANE EXPANSÉ** indéformable à portée différenciée, densité de 18kg/m<sup>3</sup> à 40kg/m<sup>3</sup>.

**PREMIER REVÊTEMENT** en polyester expansé accouplé à chaud à un velours accrochant en polyester et/ou ouate de polyester à 100% de 200g.

**PANNEAUX DE FOND COFFRE** rangement de 12-14mm en particules de bois de peuplier classe E1

**MASSIVES** Tannenholz und/oder Blöcke aus Pappelmehrschichtholz.

**SPANPLATTEN** aus Pappelholz mit 18/25 mm Schichtdicke der Klasse E1, geringer Formaldehydabgabe und natürlichen Holzfasern.

**POLYURETHANSCHAUM**, nicht verformbar und mit differenzierter Tragfähigkeit, Dichten von 18 kg/m<sup>3</sup> bis 40 kg/m<sup>3</sup>.

**ERSTER ÜBERZUG** aus Polyesterschaum, der auf Polyester-Samt und/oder 100% Polyesterwatte (zu 200 g) heiß aufkaschiert wurde.

**BODENPLATTEN** des Bettkastens aus 12-14 mm starken Spanplatten aus Pappelholz der Klasse E1.



## RING SMART PLUS



## RING VENICE PLUS



**Gonna in tinta**  
Skirt in matching colour  
Jupe en teinte  
Ton-in-Ton ausgeführter Volant

**Gonna a contrasto**  
Skirt contrasting  
Jupe en contraste  
Farblich abgesetzter Volant

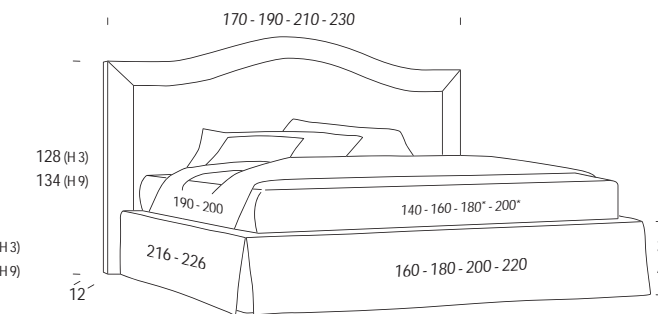
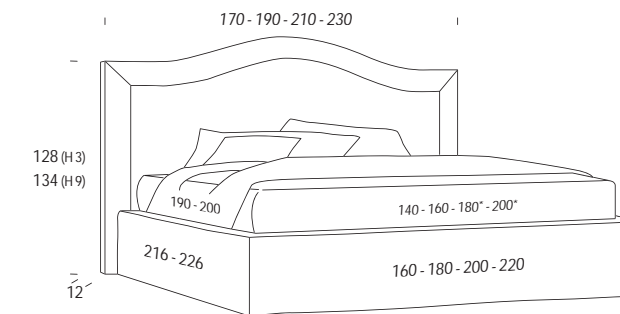

### Optional Pag 550

Meccanica / Mechanism / Mécanique / Mechanisch

Dynamic



Maverick

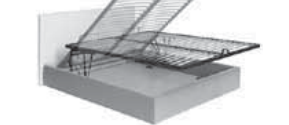

\* Rete L. 180 e L. 200 cm solo profondità 200 cm / Support W. 180 and W. 200 cm only D 200 cm / Sommier L. 180 et L. 200 cm uniquement en profondeur 200 cm / Attenrost B. 180 und B. 200 cm nur mit Tiefe 200 cm

## Optional

Rete / Support / Sommier / Lattenrost Pag 548

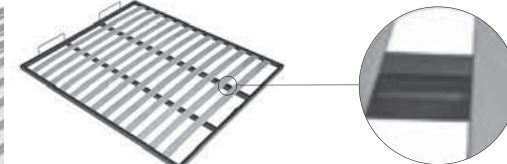
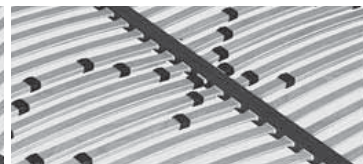
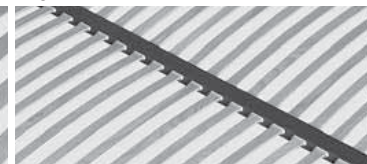
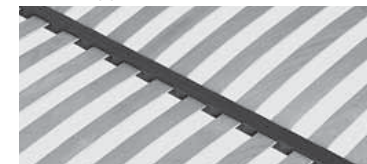

**Armony**  
(Standard)

**Thai**  
46 doghe  
46 slats  
46 attes  
46 Leisten

**Energy**  
Non applicabile a rete da 120 cm  
Not applicable to 120 cm support  
Non applicable au sommier de 120 cm  
Gilt nicht für Lattenrost zu 120 cm

**Doppio Flip**  
Solo 140/160x190/200 - 180x200  
Only 140/160x190/200 - 180x200  
Uniquement 140/160x190/200 - 180x200  
Nur 140/160x190/200 - 180x200

Pag 552



Pag 553



Pag 557



Pag 556



**Sacco contenitore multiuso**  
Multipurpose storage bag  
Sac coffre de rangement multi usage  
Mehrzweck-Aufbewahrungstasche

**Tessuto coprirete traspirante antipolvere**  
Support cover fabric breathable and dustproof  
Tissu couvre-sommier respirant anti-poussière  
Atmungsaktives, vor Staub schützendes Gewebe

**Regolatore altezza rete solo per reti in appoggio**  
Support height adjuster only for resting frames  
Réglage hauteur sommier uniquement pour sommiers à poser  
Lattenrost-Höhenverstellung nur für aufliegende Lattenroste

**Clean Up System**

# Damian



Un profilo classico per Damian, nelle curve della testiera, nel ring arrotondato. Gioco spezzato da un bordo a contrasto su angoli e testiera, quasi a sdrammatizzare tutta questa disciplina.

Damian's classic profile can be seen both in the curves on the headboard and on the rounded bed frame. Contrasting trim on the corners and headboard plays down the rigour and provides an almost playful touch.

Un profil classique pour Damian, dans les courbes de la tête de lit et dans le tour de lit arrondi. Le jeu est interrompu par un bord en contraste sur les angles et la tête de lit comme pour désamorcer toute cette discipline.

Ein klassisches Profil für Damian, in den Kurven des Kopfteils, im abgerundeten Gestell. Dies wird durch eine farblich abgesetzte Bordüre unterbrochen, fast so, als wolle man die herrschende Strenge herunterspielen.







Il comodo grande pouf coordinato nel rivestimento e nella finitura del letto da posizionare alla pediera. Un piano di seduta o un piano di appoggio disponibile con o senza contenitore...

The comfortable and big ottoman, coordinated in the cover and finishing of the bed to be placed at the footboard. A seat a support surface available with or without container...

Le grand pouf pratique assorti au revêtement et à la finition du lit à placer au pied du lit. Une surface pour s'asseoir un plan d'appui disponible avec ou sans rangement.

Der bequeme große Sitzhocker ist in Bezug und Ausführung auf das Bett abgestimmt und wird am Fußteil platziert. Eine schöne Sitzgelegenheit eine schöne Sitzgelegenheit, mit oder ohne Stauraum erhältlich...





Comunque elegante nella versione con gonnella a volant, così come nella versione svasata verso l'esterno, sollevata da un piedino importante e impreziosita da un cordoncino a contrasto.

However elegant in the version with skirt with frills. Like in the version flared outward and raised by important feet and embellished with contrasting cord.

Toujours élégante dans la version avec jupe à volant. Comme dans la version évasée vers l'extérieur et soulevée par un pied important et un cordon en contraste qui la rend plus précieuse.

Auf jeden Fall elegant sowohl in der Version mit umlaufendem Volant, als auch in der nach außen hin ausgestellten Version, die auf einem markanten Fuß ruht und durch eine farblich abgesetzte Kordel verziert wird.

# Damian

COMPLETAMENTE SFODERABILE / COMPLETELY REMOVABLE FABRIC / COMPLÈTEMENT DÉHOUSSABLE / VOLLSTÄNDIG ABZIEHBAR

**MASSELLI** in legno di abete e/o scatolati in multistrato di legno di pino.

**PANNELLI** da 18/25 mm in particelle di legno di pino in classe E1 a bassa emissione di formaldeide e fibra di legno naturale.

**ESPANSI** di poliuretano indeformabile a portanza differenziata, densità da 18 kg/mc a 40 kg/mc.

**PRIMO RIVESTIMENTO** in espanso di poliestere accoppiato a caldo a vellutino aggrappante in poliestere e/o ovatta di poliestere al 100% da 200gr.

**PANNELLI FONDO** contenitore da 12-14 mm in particelle di legno di pino in classe E1.

**FORGINGS** fir wood, and/or boxed in poplar plywood.

**PANELS** 18/25 mm in poplar wood particles class E1 low formaldehyde emission and natural wood fiber.

**POLYURETHANE FOAM** crushproof, of different capacity, density from 18 kg/mc to 40 kg/mc.

**FIRST COATING** hot bonded polyester foam, velvet adhesion in polyester and/or 100% polyester wool, 200gr.

**CONTAINER BOTTOM** panels 12-14 mm in poplar wood particles class E1.

**TIGE** en pin et/ou boitiers en multicouche en bois de peuplier.

**PANNEAUX** de 18/25 mm en particules de bois de peuplier classe E1 à faible émission de formaldéhyde et fibre de bois naturelle.

**POLYURÉTHANE EXPANSÉ** indéformable à portée différenciée, densité de 18kg/m<sup>3</sup> à 40kg/m<sup>3</sup>.

**PREMIER REVÊTEMENT** en polyester expansé accouplé à chaud à un velours accrochant en polyester et/ou ouate de polyester à 100% de 200g.

**PANNEAUX DE FOND COFFRE** rangement de 12-14mm en particules de bois de peuplier classe E1.

**MASSIVES** Tannenholz und/oder Blöcke aus Pappelmehrschichtholz.

**SPANPLATTEN** aus Pappelholz mit 18/25 mm Schichtdicke der Klasse E1, geringer Formaldehydabgabe und natürlichen Holzfasern.

**POLYURETHANSCHAUM** mit Dichten von 18 kg/m<sup>3</sup> bis 40 kg/m<sup>3</sup>. Kissen mit Watte zu 300 g überzogen.

**ERSTER ÜBERZUG** aus Polyesterschaum, der auf Polyester-Samt und/oder 100% Polyesterwatte (zu 200 g) heiß aufkaschiert wurde.

**BODENPLATTEN** des Bettkastens aus 12-14 mm starken Spanplatten aus Pappelholz der Klasse E1.



## Optional

Rete / Support / Sommier / Lattenrost Pag 548

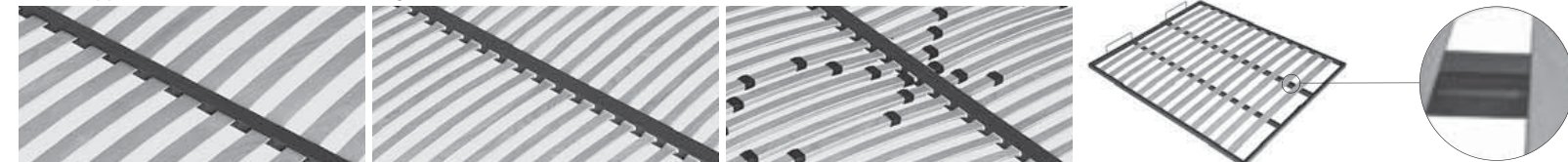

**Armony** (Standard)

**Thai**  
46 doghe  
46 slats  
46 attes  
46 Leisten

**Energy**  
Non applicabile a rete da 120 cm  
Not applicable to 120 cm support  
Non applicable au sommier de 120 cm  
Gilt nicht für Lattenrost zu 120 cm

**Doppio Flip**  
Solo 140/160x190/200 - 180x200  
Only 140/160x190/200 - 180x200  
Uniquement 140/160x190/200 - 180x200  
Nur 140/160x190/200 - 180x200

Pag 552



**Sacco contenitore multiuso**  
Multipurpose storage bag  
Sac coffre de rangement multi usage  
Mehrzweck-Aufbewahrungstasche

Pag 553



**Tessuto coprirete traspirante antipolvere**  
Support cover fabric breathable and dustproof  
Tissu couvre-sommier transpirant anti-poussière  
Atmungsaktives, vor Staub schützendes Gewebe

Pag 557



**Regolatore altezza rete solo per reti in appoggio**  
Support height adjuster only for resting frames  
Réglage hauteur sommier uniquement pour sommiers à poser  
Lattenrost-Höhenverstellung nur für aufliegende Lattenroste

Pag 556



**Clean Up System**

## RING SMART



## RING VENICE



Gonna in tinta / Skirt in plain colour  
/ Jupe en teinte / Ton-in-Ton ausgeführter Volant

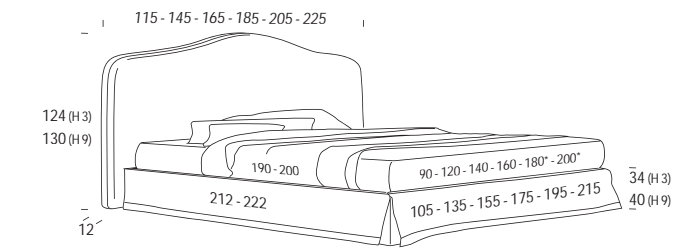

Gonna a contrasto / Skirt contrasting  
/ Jupe en contraste / Farblich abgesetzter Volant

\* Rete L. 180 e L. 200 cm solo profondità 200 cm / Support W. 180 and W. 200 cm only D 200 cm  
/ Sommier L. 180 et L. 200 cm uniquement en profondeur 200 cm / Attenrost B. 180 und B. 200 cm nur mit Tiefe 200 cm

Standard BASIC H 3



Wengé / Wengé  
/ Wengé / Wengé

Nero / Black  
/ Noir / Schwarz

Optional LUX H 3



Wengé / Wengé  
/ Wengé / Wengé

Nero / Black  
/ Noir / Schwarz

Optional VISUAL H 9



Wengé / Wengé  
/ Wengé / Wengé

Nero / Black  
/ Noir / Schwarz



Argento / Silver  
/ Argent / Silber

Bianco / White  
/ Blanc / Weiß



Cromo / Chrome  
/ Chromé / Chrom

Bianco / White  
/ Blanc / Weiß



Argento / Silver  
/ Argent / Silber

Bianco / White  
/ Blanc / Weiß

## RING CHIC



\* Rete L. 180 e L. 200 cm solo profondità 200 cm / Support W. 180 and W. 200 cm only D 200 cm  
/ Sommier L. 180 et L. 200 cm uniquement en profondeur 200 cm / Attenrost B. 180 und B. 200 cm nur mit Tiefe 200 cm

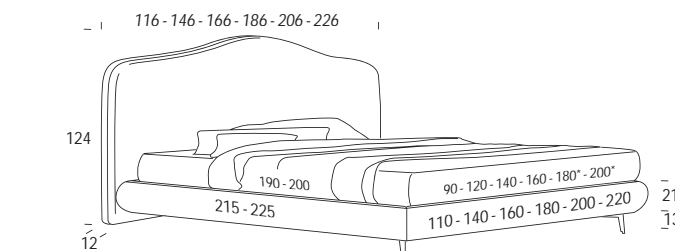

Standard BLADE H 13 Pag 546



Satinato / Satin  
/ Satiné / Satiniert

Bronzato / Bronze  
/ Bronzé / Bronziert

Optional TOWER H 13



Optional PLEXY H 13



Pag 546

Optional Pag 550

Meccanica / Mechanism  
/ Mécanique / Mechanisch

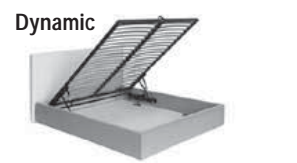

Dynamic

# Jason



Jason reinterpreta lo stile classico, portando eleganza e lusso: sembrerà di entrare nella camera di un nobile d'altri tempi.

Jason reinterprets classic style, introducing elegance and luxury. It gives the feel of walking into the bedroom of an aristocrat from bygone days.

Jason réinterprète le style classique avec élégance et luxe: ce sera comme entrer dans la chambre d'un noble d'autrefois.

Jason interpretiert den klassischen Stil neu und bringt Eleganz und Luxus mit sich: das Modell erweckt den Anschein, als würde man das Zimmer eines Adligen aus anderen Zeiten betreten.









Lo stile interpreta a modo suo una tendenza classica. Per vivere all'insegna dell'eleganza oltre che del comfort.

Style reinterprets a classic trend in its own way. To live with elegance and comfort.

Le style interprète à sa manière une tendance classique. Pour vivre sous le signe de l'élégance en plus du confort.

Der Stil interpretiert einen klassischen Trend auf seine ganz eigene Art und Weise. Im Zeichen von Eleganz und Komfort.





Il ring riprende il tema delle rotondità classiche e morbide della testiera.

The ring reprises the theme of the classic and soft roundness of the headboard.

Le cadre de lit reprend le thème des rondeurs classiques et moelleuses de la tête de lit.

Das Gestell greift das Thema der klassischen, weichen Rundung des Kopfteils wieder auf.



# Jason

COMPLETAMENTE SFODERABILE / COMPLETELY REMOVABLE FABRIC / COMPLÈTEMENT DÉHOUSSABLE / VOLLSTÄNDIG ABZIEHBAR

**MASSELLI** in legno di abete e/o scatolati in multistrato di legno di pioppo.

**PANNELLI** da 18/25 mm in particelle di legno di pioppo in classe E1 a bassa emissione di formaldeide e fibra di legno naturale.

**ESPANSI** di poliuretano indeformabile a portanza differenziata, densità da 18 kg/mc a 40 kg/mc.

**PRIMO RIVESTIMENTO** in espanso di poliestere accoppiato a caldo a vellutino aggrappante in poliestere e/o ovatta di poliestere al 100% da 200gr.

**PANNELLI FONDO** contenitore da 12-14 mm in particelle di legno di pioppo in classe E1.

**FORGINGS** fir wood, and/or boxed in poplar plywood.

**PANELS** 18/25 mm in poplar wood particles class E1 low formaldehyde emission and natural wood fiber.

**POLYURETHANE FOAM** crushproof, of different capacity, density from 18 kg/mc to 40 kg/mc.

**FIRST COATING** hot bonded polyester foam, velvet adhesion in polyester and/or 100% polyester wool, 200gr.

**CONTAINER BOTTOM** panels 12-14 mm in poplar wood particles class E1.

**TIGE** en pin et/ou boitiers en multicouche en bois de peuplier.

**PANNEAUX** de 18/25 mm en particules de bois de peuplier classe E1 à faible émission de formaldéhyde et fibre de bois naturelle.

**POLYURÉTHANE EXPANSÉ** indéformable à portée différenciée, densité de 18kg/m<sup>3</sup> à 40kg/m<sup>3</sup>.

**PREMIER REVÊTEMENT** en polyester expansé accouplé à chaud à un velours accrochant en polyester et/ou ouate de polyester à 100% de 200g.

**PANNEAUX DE FOND COFFRE** rangement de 12-14mm en particules de bois de peuplier classe E1.

**MASSIVES** Tannenholz und/oder Blöcke aus Pappelmehrschichtholz.

**SPANPLATTEN** aus Pappelholz mit 18/25 mm Schichtdicke der Klasse E1, geringer Formaldehydabgabe und natürlichen Holzfasern.

**POLYURETHANSCHAUM**, nicht verformbar und mit differenzierter Tragfähigkeit, Dichten von 18 kg/m<sup>3</sup> bis 40 kg/m<sup>3</sup>.

**ERSTER ÜBERZUG** aus Polyesterschaum, der auf Polyester-Samt und/oder 100% Polyesterwatte (zu 200 g) heiß aufkaschiert wurde.

**BODENPLATTEN** des Bettkastens aus 12-14 mm starken Spanplatten aus Pappelholz der Klasse E1.



## Optional

Rete / Support / Sommier / Lattenrost Pag 548

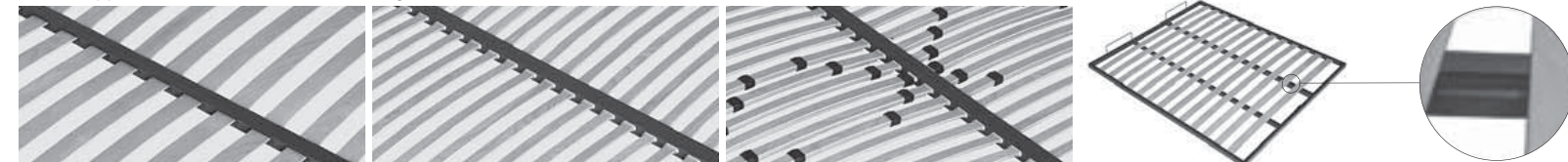

**Armony** (Standard)

**Thai**  
46 doghe  
46 slats  
46attes  
46 Leisten

**Energy**  
Non applicabile a rete da 120 cm  
Not applicable to 120 cm support  
Non applicable au sommier de 120 cm  
Gilt nicht für Lattenrost zu 120 cm

**Doppio Flip**  
Solo 140/160x190/200 - 180x200  
Only 140/160x190/200 - 180x200  
Uniquement 140/160x190/200 - 180x200  
Nur 140/160x190/200 - 180x200

Pag 552



**Sacco contenitore multiuso**  
Multipurpose storage bag  
Sac coffre de rangement multi usage  
Mehrzweck-Aufbewahrungstasche

Pag 553



**Tessuto coprirete traspirante antipolvere**  
Support cover fabric breathable and dustproof  
Tissu couvre-sommier respirant anti-poussière  
Atmungsaktives, vor Staub schützendes Gewebe

Pag 557



**Regolatore altezza rete solo per reti in appoggio**  
Support height adjuster only for resting frames  
Réglage hauteur sommier uniquement pour sommiers à poser  
Lattenrost-Höhenverstellung nur für aufliegende Lattenroste

Pag 556



**Clean Up System**

## VENICE PLUS



Gonna in tinta / Skirt in plain colour  
/ Jupe en teinte / Ton-in-Ton ausgeführt  
Volant

Gonna a contrasto / Skirt contrasting  
/ Jupe en contraste / Farblich abgesetzter Volant

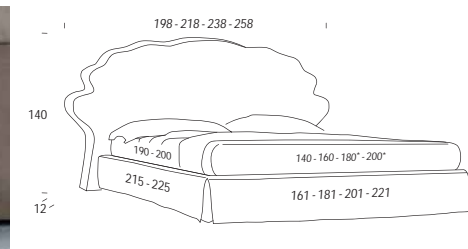

\* Rete L. 180 e L. 200 cm solo profondità 200 cm / Support W. 180 and W. 200 cm only D 200 cm  
/ Sommier L. 180 et L. 200 cm uniquement en profondeur 200 cm / Attenrost B. 180 und B. 200 cm nur mit Tiefe 200 cm

Standard BASIC H 3 Pag 543



Wengé / Wengé  
/ Wengé / Wengé

Nero / Black  
/ Noir / Schwarz

Argento / Silver  
/ Argent / Silber

Bianco / White  
/ Blanc / Weiß

Wengé / Wengé  
/ Wengé / Wengé

Nero / Black  
/ Noir / Schwarz

Cromo / Chrome  
/ Chrome / Chrom

Bianco / White  
/ Blanc / Weiß

Optional LUX H 3 Pag 543



## RING BIG

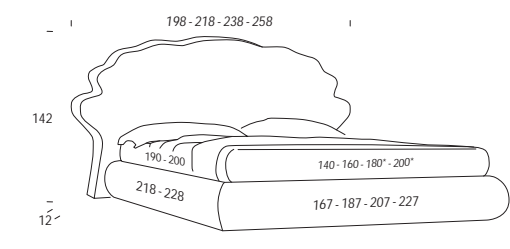

\* Rete L. 180 e L. 200 cm solo profondità 200 cm / Support W. 180 and W. 200 cm only D 200 cm  
/ Sommier L. 180 et L. 200 cm uniquement en profondeur 200 cm / Attenrost B. 180 und B. 200 cm nur mit Tiefe 200 cm

Standard CLASSIC H 5 Pag 543



Wengé / Wengé / Wengé / Wengé

Bianco / White / Blanc / Weiß

Argento / Silver / Argent / Silber

## Optional

Meccanica / Mechanism  
/ Mécanique / Mechanisch

Dynamic



Maverick

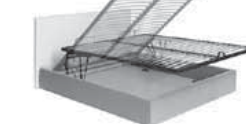

## RING CHIC

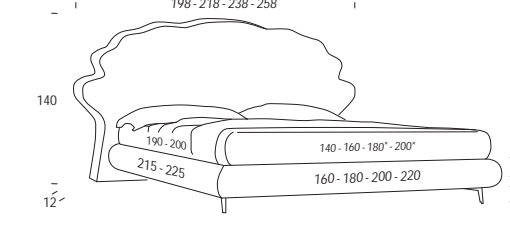

\* Rete L. 180 e L. 200 cm solo profondità 200 cm / Support W. 180 and W. 200 cm only D 200 cm  
/ Sommier L. 180 et L. 200 cm uniquement en profondeur 200 cm / Attenrost B. 180 und B. 200 cm nur mit Tiefe 200 cm

Standard BLADE H 13 Pag 546



Satinato / Satin  
/ Satiné / Satiniert

Bronzato / Bronze  
/ Bronze / Bronziert

Optional TOWER H 13



Optional PLEXY H 13



Pag 546

## Optional

Meccanica / Mechanism  
/ Mécanique / Mechanisch

Dynamic



# Contract / Home Solution

Idee e soluzioni per il mondo dell'hôtellerie che strizzano l'occhio anche agli ambienti domestici, offrendo la possibilità di creare con originalità. I pannelli della collezione Contract / Home Solutions sono infatti estremamente versatili e possono essere combinati per arredare non solo camere d'albergo, ma anche per esempio colorate stanze di bambini e zone living.

Ideas and solutions for the world of hôtellerie also looking at domestic rooms, providing the opportunity of creating with originality. The panels of the collection Contract/Home Solutions are in fact highly versatile and may be combined to furnish not only hotel rooms but also childrens colourful rooms and living spaces.

Idées et solutions pour le monde de l'hôtellerie qui clignent l'œil également vers les milieux domestiques, en offrant la possibilité de créer avec originalité. Les panneaux de la collection Contract/Home Solutions sont en effet extrêmement versatiles et peuvent se combiner afin de décorer non seulement les chambres à coucher d'hôtel, mais aussi par exemple colorer les chambres d'enfants et les zones living.

Ideen und Lösungen für die Hotellerie, die auch für den Wohnbereich geeignet sind und originelle Gestaltungsmöglichkeiten bieten. Die Paneele aus der Contract / Home Solutions Kollektion sind äußerst vielseitig und lassen sich nicht nur zur Einrichtung von Hotelzimmern, sondern beispielsweise auch von farbenfrohen Kinderzimmern und Wohnbereichen kombinieren.

# Sommier Collection

Il contract di qualità.

Un programma articolato e ricco di sommier imbottiti e completi di sistema di boiserie componibile. Tutti completamente sfoderabili. Piani letto / supporti per il materasso in tessuto tridimensionale ignifugo e traspirante o con rete a doghe.

Bassi a pavimento o alti, con piedini o ruote per una facile movimentazione e componibilità.

The quality contract.

A structured program and rich in padded sommier equipped with a woodwork modular system and all with removable covers. Bedbases/supports for the mattress in 3D, fireproof and breathable fabric or with slatted frame.

Floor-level or high, with feet or on wheels to be easily handled and modulated.

Le contrat de qualité.

Un programme articulé et riche de sommiers rembourrés, complétés par des systèmes de boiserie modulables. Tous entièrement déhoussables. Pourtours de lit / supports pour le matelas en tissu tridimensionnel ignifuge et transpirant ou avec sommier à lattes.

Bas jusqu'au plancher ou hauts, avec petits pieds ou roues pour un déplacement facile et une grande modularité.

Das feine Contract-Modell.

Ein gegliedertes und umfassendes Programm mit gepolsterten Sommier-Bettrahmen und modularem Boiserie-System. Alle sind vollständig abziehbar. Liegeflächen / Matratzenunterlagen aus dreidimensionalem, feuerhemmendem und atmungsaktivem Gewebe oder mit Lattenrost.

Bodennah oder hoch, mit Füßen oder Rollen für ein vereinfachtes Umstellen oder mehr Modularität.

Ring Sommy Small



Ring Sommy Big

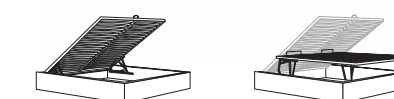

Ring Sommy Small Air



Ring Sommy Big Air



Ring Sommy Star



Ring Sommy Moon



Ring Sommy Sky



Ring Sommy Ocean



Version  
**Sommy Small**

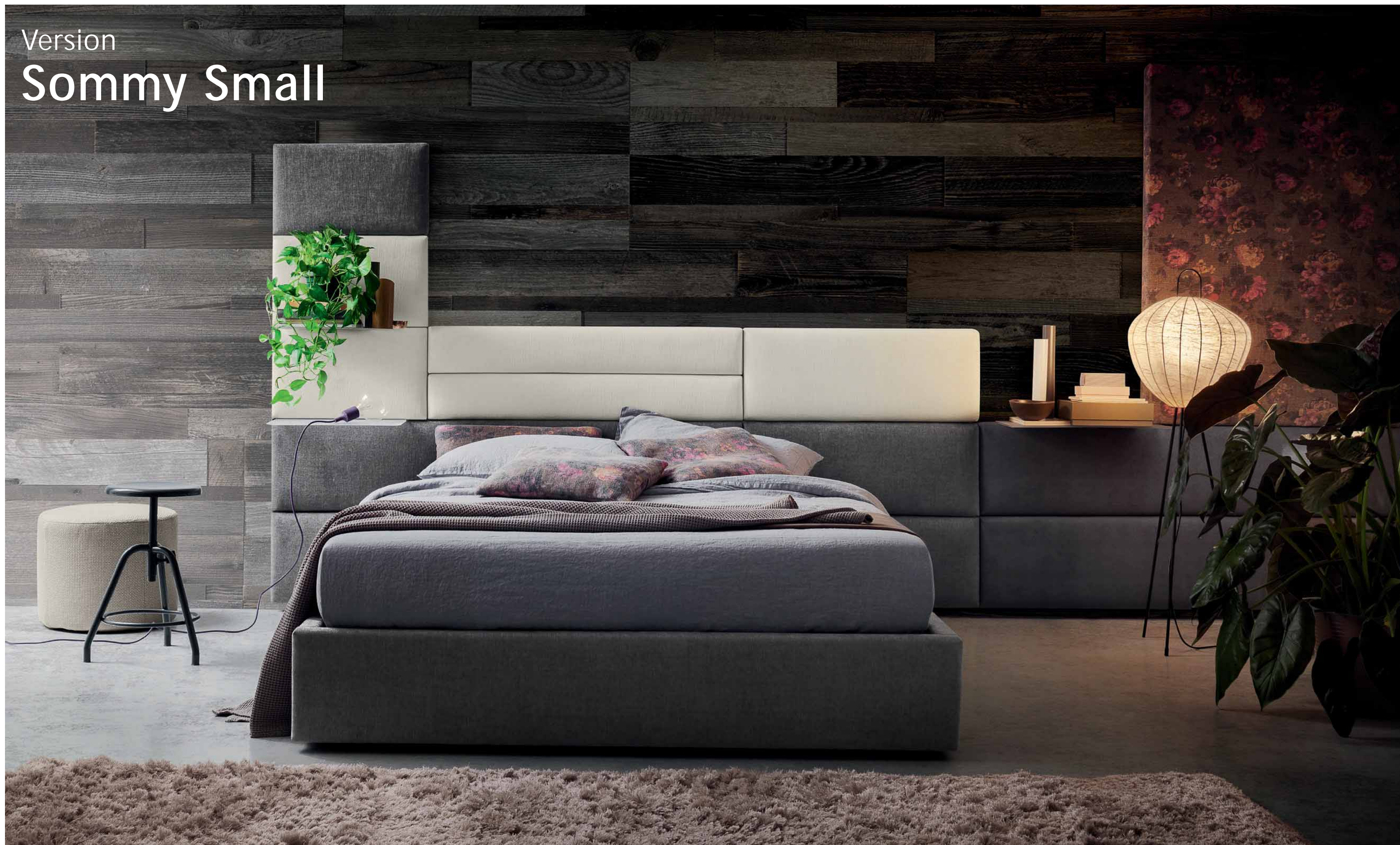

Version  
**Sommy Big**





## Ring Sommy Small



sp. 6 / th. 6  
ép. 6 / St. 6 cm



Disponibili nelle versioni  
Available in the versions  
Disponibles dans les versions  
Erhältlich in den Versionen



Senza rete  
Without bedframe  
Sans sommier  
Ohne Bettenrost



Rete in appoggio  
Resting frame  
Avec sommier en appui  
Mit aufliegendem Bettenrost

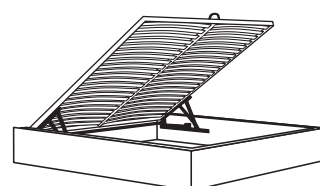

Dynamic  
con contenitore e meccanismo  
storage space and Dynamic  
mechanism  
avec conteneurs et mécanisme  
mit Bettkasten und Mechanismus

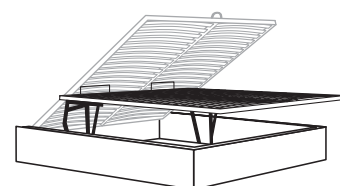

Maverick  
con contenitore e meccanismo  
with storage space and Maverick  
mechanism  
avec conteneurs et mécanisme  
mit Bettkasten und Mechanismus

Non disponibile versione Maverick nella variante Air  
Not available Maverick version in the Air variant  
Version Maverick non disponible dans la variante Air  
In der Air-Variante die Maverich-Version ist nicht verfügbar

## Ring Sommy Big



sp. 9 / th. 9  
ép. 9 / St. 9 cm



Disponibili nelle versioni  
Available in the versions  
Disponibles dans les versions  
Erhältlich in den Versionen

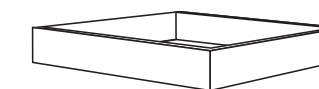

Senza rete  
Without bedframe  
Sans sommier  
Ohne Bettenrost



Rete in appoggio  
Resting frame  
Avec sommier en appui  
Mit aufliegendem Bettenrost

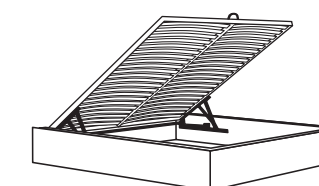

Dynamic  
con contenitore e meccanismo  
storage space and Dynamic  
mechanism  
avec conteneurs et mécanisme  
mit Bettkasten und Mechanismus

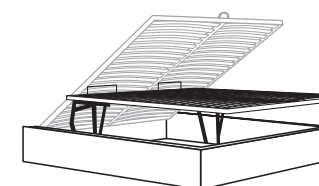

Maverick  
con contenitore e meccanismo  
with storage space and Maverick  
mechanism  
avec conteneurs et mécanisme  
mit Bettkasten und Mechanismus

Non disponibile versione Maverick nella variante Air  
Not available Maverick version in the Air variant  
Version Maverick non disponible dans la variante Air  
In der Air-Variante die Maverich-Version ist nicht verfügbar

# Ring Sommy - Small/Big

COMPLETAMENTE SFODERABILE / COMPLETELY REMOVABLE FABRIC / COMPLÈTEMENT DÉHOUSSABLE / VOLLSTÄNDIG ABZIEHBAR

**MASSELLI** in legno di abete e/o scatolati in multistrato di legno di pioppo.

**PANNELLI** da 18/25 mm in particelle di legno di pioppo in classe E1 a bassa emissione di formaldeide e fibra di legno naturale.

**ESPANSI** di poliuretano indeformabile a portanza differenziata, densità da 18 kg/mc a 40 kg/mc.

**PRIMO RIVESTIMENTO** in espanso di poliestere accoppiato a caldo a vellutino aggrappante in poliestere e/o ovatta di poliestere al 100% da 200gr.

**PANNELLI FONDO** contenitore da 12-14 mm in particelle di legno di pioppo in classe E1.

**FORGINGS** fir wood, and/or boxed in poplar plywood.

**PANELS** 18/25 mm in poplar wood particles class E1 low formaldehyde emission and natural wood fiber.

**POLYURETHANE FOAM**, crushproof, of different capacity, density from 18 kg/mc to 40 kg/mc.

**FIRST COATING** hot bonded polyester foam, velvet adhesion in polyester and/or 100% polyester wool, 200gr.

**CONTAINER BOTTOM PANELS** 12-14 mm in poplar wood particles class E1.

**TIGE** en pin et/ou boitiers en multicouche en bois de peuplier.

**PANNEAUX** de 18/25 mm en particules de bois de peuplier classe E1 à faible émission de formaldéhyde et fibre de bois naturelle.

**POLYURÉTHANE EXPANSÉ** indéformable à portée différenciée, densité de 18kg/m<sup>2</sup> à 40kg/m<sup>2</sup>.

**PREMIER REVÊTEMENT** en polyester expansé accouplé à chaud à un velours accrochant en polyester et/ou ouate de polyester à 100% de 200g.

**PANNEAUX DE FOND COFFRE RANGEMENT** de 12-14mm en particules de bois de peuplier classe E1.

**MASSIVES** Tannenholz und/oder Blöcke aus Pappelholz.

**SPANPLATTEN** aus Pappelholz mit 18/25 mm Schichtdicke der Klasse E1, geringer Formaldehydabgabe und natürlichen Holzfasern.

**SCHAUM**, formbeständig und mit differenzierter Tragfähigkeit, Dichten von 18 kg/m<sup>3</sup> bis 40 kg/m<sup>3</sup>.

**ERSTER ÜBERZUG** aus Polyesterschaum, der auf Polyester-Samt und/oder 100% Polyesterwatte (zu 200 g) heiß aufkaschiert wurde.

**BODENPLATTEN** des Bettkastens aus 12-14 mm starken Spanplatten aus Pappelholz der Klasse E1.

## Ring Sommy Small

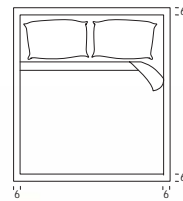

## Ring Sommy Big

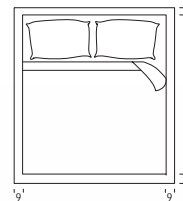

### Optional

Rete / Support / Sommier / Lattenrost Pag 548

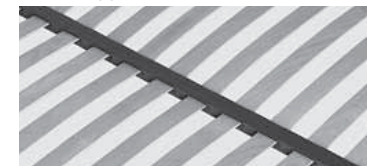

**Armony**  
(Standard)

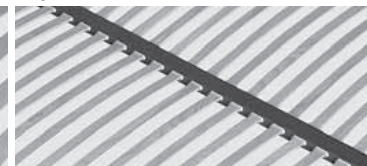

**Thai**  
46 doghe  
46 slats  
46 attes  
46 Leisten

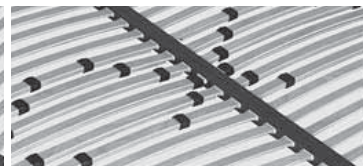

**Energy**  
Non applicabile a rete da 120 cm  
Not applicable to 120 cm support  
Non applicable au sommier de 120 cm  
Gilt nicht für Lattenrost zu 120 cm

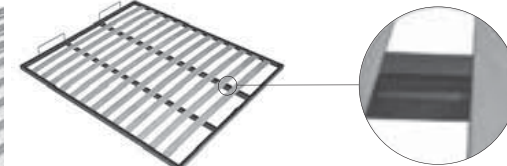

**Doppio Flip**  
Solo 140/160x190/200 - 180x200  
Only 140/160x190/200 - 180x200  
Uniquement 140/160x190/200 - 180x200  
Nur 140/160x190/200 - 180x200

Pag 552



**Sacco contenitore multiuso**  
Multipurpose storage bag  
Sac coffre de rangement multi usage  
Mehrzweck-Aufbewahrungstasche

Pag 553



**Tessuto coprirete traspirante antipolvere**  
Support cover fabric breathable and dustproof  
Tissu couvre-sommier respirant anti-poussière  
Atmungsaktives, vor Staub schützendes Gewebe

Pag 557



**Regolatore altezza rete solo per reti in appoggio**  
Support height adjuster only for resting frames  
Réglage hauteur sommier uniquement pour sommiers à poser  
Lattenrost-Höhenverstellung nur für aufliegende Lattenroste

Pag 556



**Clean Up System**

### RELAX SYSTEM

#### Ring Sommy - Small

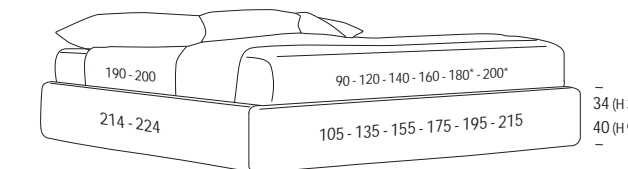

#### Ring Sommy - Big

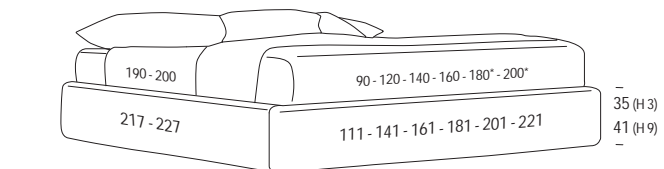

\* Rete L. 180 e L. 200 cm solo profondità 200 cm / Support W. 180 and W. 200 cm only D 200 cm / Sommier L. 180 et L. 200 cm uniquement en profondeur 200 cm / Attenrost B. 180 und B. 200 cm nur mit Tiefe 200 cm

Standard BASIC H 3 Pag 543



Wengé / Wengé  
/ Wengé / Wengé

Pag 543



Nero / Black  
/ Noir / Schwarz

Optional LUX H 3 Pag 543



Wengé / Wengé  
/ Wengé / Wengé

Pag 543



Nero / Black  
/ Noir / Schwarz

Optional VISUAL H 9 Pag 543



Wengé / Wengé  
/ Wengé / Wengé

Pag 543



Nero / Black  
/ Noir / Schwarz



Argento / Silver  
/ Argent / Silber



Bianco / White  
/ Blanc / Weiß



Cromo / Chrome  
/ Chrome / Chrom



Bianco / White  
/ Blanc / Weiß



Argento / Silver  
/ Argent / Silber



Bianco / White  
/ Blanc / Weiß

#### Ring Sommy - Small Air

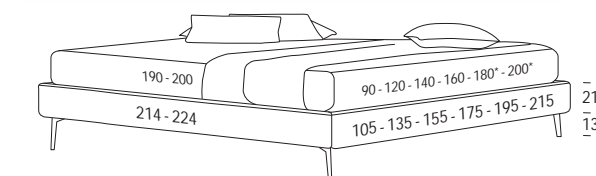

#### Ring Sommy - Big Air

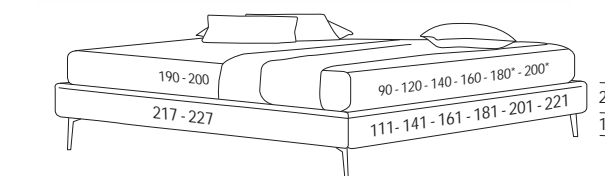

\* Rete L. 180 e L. 200 cm solo profondità 200 cm / Support W. 180 and W. 200 cm only D 200 cm / Sommier L. 180 et L. 200 cm uniquement en profondeur 200 cm / Attenrost B. 180 und B. 200 cm nur mit Tiefe 200 cm

Standard BLADE H 13 Pag 546



Satinato / Satin  
/ Satiné / Satiniert

Pag 546



Bronzato / Bronze  
/ Bronze / Bronziert

Optional TOWER H 13



Optional PLEXY H 13



Pag 546

### Optional

Pag 548

Meccanica / Mechanism  
/ Mécanique / Mechanisch

Dynamic



Version  
**Sommy Star**

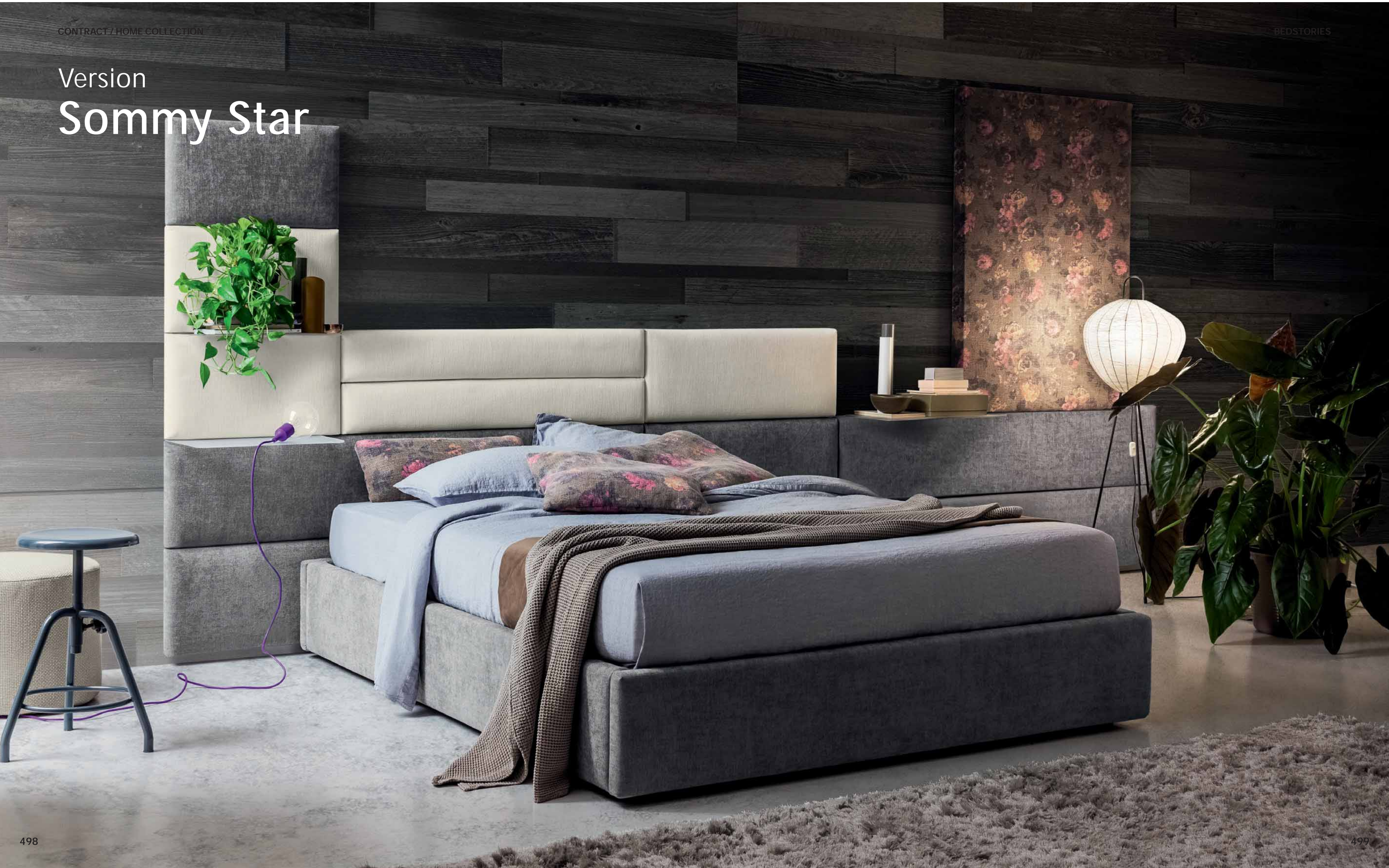

Version  
**Sommy Star**

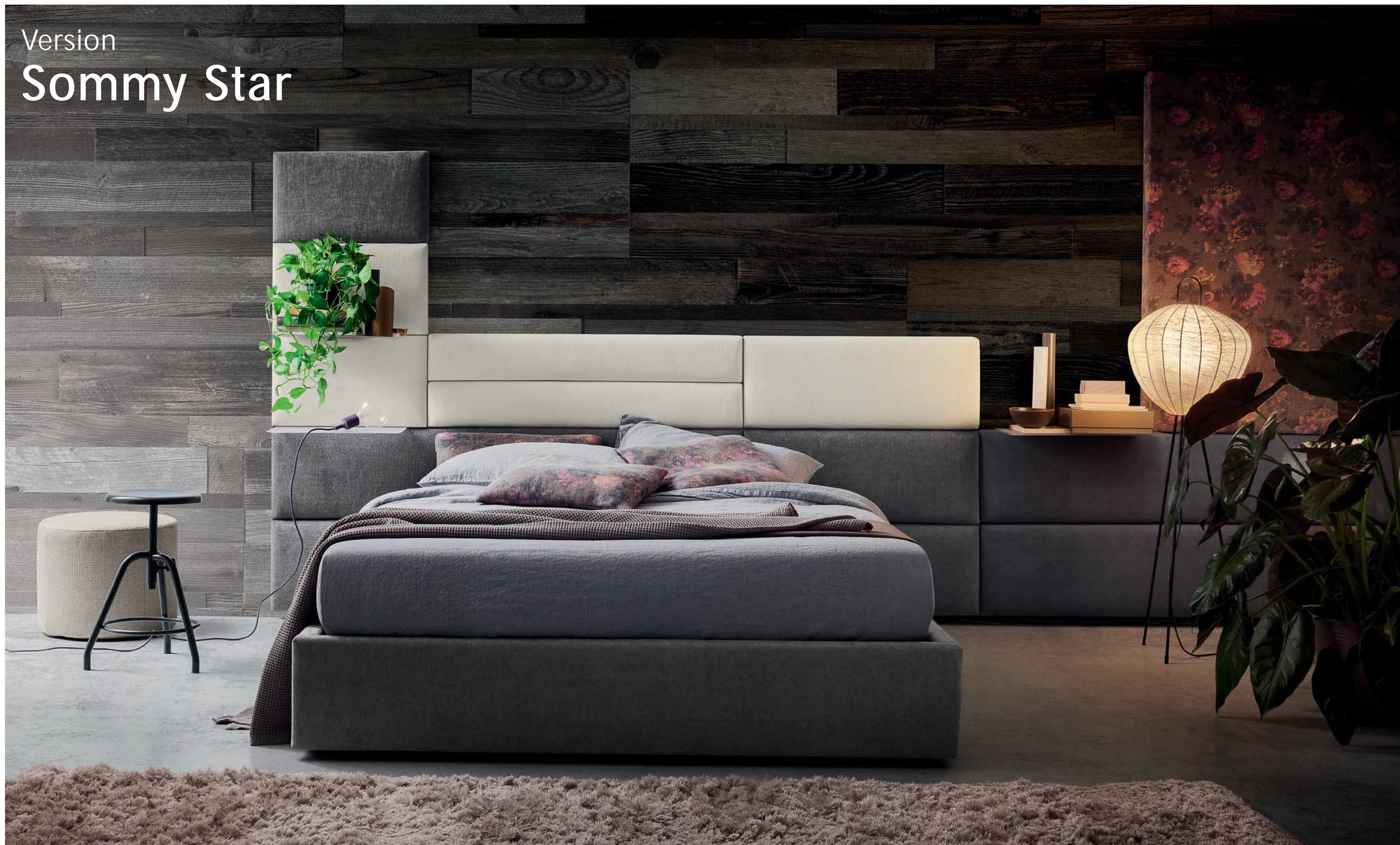

## Sommy Moon



## Sommy Star



Versione sommier matrimoniale  
Disponibile con rete a doghe.  
Possibilità di avere:  
A. cassettone estraibile Dx o Sx  
B. letto singolo estraibile con  
apertura automatica  
C. letto singolo estraibile con  
apertura semiautomatica.

Double sommier version  
Available with slatted frame  
Options:  
A. pull-out drawer Right or Left  
B. Removable single bed with  
automatic opening  
C. Removable single bed with semi-  
automatic opening

Version sommier deux places  
Disponibile avec sommier à lattes.  
Possibilité d'avoir :  
A. tiroir amovible Dx ou Sx  
B. lit simple extractible avec  
ouverture automatique  
C. lit simple extractible avec  
ouverture semi- automatique.

Version des Sommier-Doppelbetts  
Steht mit Lattenrost zur Verfügung.  
Folgende Optionen stehen zur  
Wahl:  
A. ziehbare Schublade  
B. ausziehbares Einzelbett mit  
automatischer Öffnung  
C. ausziehbares Einzelbett mit  
halbautomatischer Öffnung.



Apertura automatica  
Automatic opening  
Ouverture automatique  
Automatische Öffnung



Apertura semi-automatica  
Semiautomatic opening  
Ouverture semi-automatique  
Halbautomatischer Öffnung



# Ring Sommy Star



sp. 6 / th. 6 cm



ép. 6 / St. 6 cm

Versione con cassettone  
Version with big drawer  
Version avec un grand tiroir  
Version mit großer Schublade



Versione con letto singolo  
Version with big drawer  
Version with un grand tiroir  
Version mit Einzelbett



# Ring Sommy Moon



sp. 9 / th. 9 cm



ép. 9 / St. 9 cm

Versione con cassettone  
Version with big drawer  
Version avec un grand tiroir  
Version mit großer Schublade



Versione con letto singolo  
Version with big drawer  
Version with un grand tiroir  
Version mit Einzelbett



# Ring Sommy - Star/Moon

COMPLETAMENTE SFODERABILE / COMPLETELY REMOVABLE FABRIC / COMPLÈTEMENT DÉHOUSSABLE / VOLLSTÄNDIG ABZIEHBAR

**MASSELLI** in legno di abete e/o scatolati in multistrato di legno di pioppo.

**PANNELLI** da 18/25 mm in particelle di legno di pioppo in classe E1 a bassa emissione di formaldeide e fibra di legno naturale.

**ESPANSI** di poliuretano indeformabile a portanza differenziata, densità da 18 kg/mc a 40 kg/mc.

**PRIMO RIVESTIMENTO** in espanso di poliestere accoppiato a caldo a vellutino aggrappante in poliestere e/o ovatta di poliestere al 100% da 200gr.

**FORGINGS** fir wood, and/or boxed in poplar plywood.

**PANELS** 18/25 mm in poplar wood particles class E1 low formaldehyde emission and natural wood fiber.

**POLYURETHANE FOAM**, crushproof, of different capacity, density from 18 kg/mc to 40 kg/mc.

**FIRST COATING** hot bonded polyester foam, velvet adhesion in polyester and/or 100% polyester wool, 200gr.

**TIGE** en pin et/ou boitiers en multicouche en bois de peuplier.

**PANNEAUX** de 18/25 mm en particules de bois de peuplier classe E1 à faible émission de formaldéhyde et fibre de bois naturelle.

**POLYURÉTHANE EXPANSÉ** indéformable à portée différenciée, densité de 18kg/m<sup>3</sup> à 40kg/m<sup>3</sup>.

**PREMIER REVÊTEMENT** en polyester expansé accouplé à chaud à un velours accrochant en polyester et/ou ouate de polyester à 100% de 200g.

**MASSIVES** Tannenholz und/oder Blöcke aus Pappelmehrschichtholz.

**SPANPLATTEN** aus Pappelholz mit 18/25 mm Schichtdicke der Klasse E1, geringer Formaldehydabgabe und natürlichen Holzfasern.

Polyurethan**SCHAUM**, formbeständig und mit differenzierter Tragfähigkeit, Dichten von 18 kg/m<sup>3</sup> bis 40 kg/m<sup>3</sup>.

**ERSTER ÜBERZUG** aus Polyesterschaum, der auf Polyester-Samt und/oder 100% Polyesterwatte (zu 200 g) heiß aufkaschiert wurde.

## Ring Sommy - Star

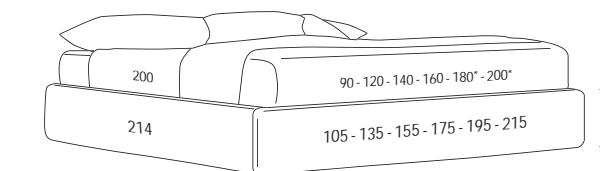

## Ring Sommy - Moon

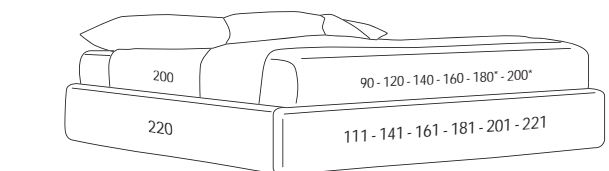

\* Rete L. 180 e L. 200 cm solo profondità 200 cm / Support W. 180 and W. 200 cm only D 200 cm  
/ Sommier L. 180 et L. 200 cm uniquement en profondeur 200 cm / Attenrost B. 180 und B. 200 cm nur mit Tiefe 200 cm

## Ring Sommy Star



## Ring Sommy Moon



### Optional

Rete / Support / Sommier / Lattenrost Pag 546

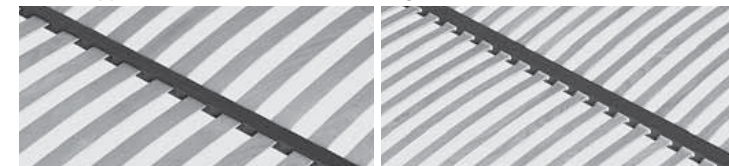

**Armony**  
(Standard)

**Thai**  
46 doghe  
46 slats  
46 attes  
46 Leisten

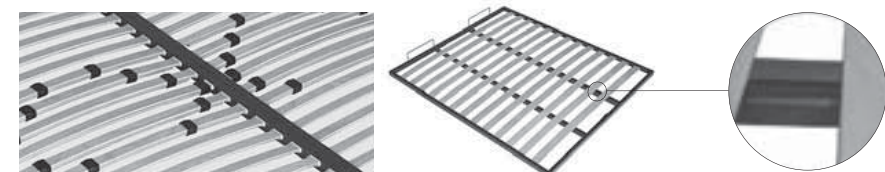

**Energy**  
Non applicabile a rete da 120 cm  
Not applicable to 120 cm support  
Non applicable au sommier de 120 cm  
Gilt nicht für Lattenrost zu 120 cm

**Doppio Flip**  
Solo 140/160/180x200  
Only 140/160/180x190/200  
Uniquement 140/160/180x200  
Nur 140/160/180x200

Pag 550



**Sacco contenitore multiuso**  
Multipurpose storage bag  
Sac coffi re de rangement multi usage  
Mehrzweck-Aufbewahrungstasche



Versione sommier matrimoniale.  
Disponibile con rete a doghe.  
Possibilità di avere: cassettone.

Queen size box spring version.  
Available with slatted support.  
Possibility to have a: big drawer.

Version sommier deux places.  
Disponible avec sommier à lattes.  
Possibilité d'avoir: un grand tiroir.

Version des Sommier-Doppelbetts.  
Steht mit Lattenrost zur Verfügung.  
Folgendes ist erhältlich: große Schublade.



Versione sommier matrimoniale.  
Disponibile con rete a doghe.  
Possibilità di avere: letto singolo estraibile con apertura semiautomatica.

Queen size box spring version.  
Available with slatted support.  
Possibility to have a: pull-out twin bed with semiautomatic opening.

Version sommier deux places.  
Disponible avec sommier à lattes.  
Possibilité d'avoir: un lit 1 place extractible avec ouverture semi-automatique.

Version des Sommier-Doppelbetts.  
Steht mit Lattenrost zur Verfügung.  
Folgendes ist erhältlich: Ausziehbares Einzelbett mit halbautomatische Öffnung.



Versione sommier matrimoniale.  
Disponibile con rete a doghe.  
Possibilità di avere: letto singolo estraibile con apertura automatica.

Queen size box spring version.  
Available with slatted support.  
Possibility to have a: pull-out twin bed with automatic.

Version sommier deux places.  
Disponible avec sommier à lattes.  
Possibilité d'avoir: un lit 1 place extractible avec ouverture automatique.

Version des Sommier-Doppelbetts.  
Steht mit Lattenrost zur Verfügung.  
Folgendes ist erhältlich: ausziehbares Einzelbett mit automatischer Öffnung.

Version  
**Sommy Sky**







Sommier disponibili con piedini finitura alluminio dotati di ruote per facile movimentazione o cambio di assetto. Boiserie dalla modularità funzionale all'utilizzo in qualunque soluzione di ambiente.

Box spring available with feet with aluminum finish with wheels for easy handling or change of position. Wall panel with functional modularity for use in any environment.

Sommiers disponibles avec pieds aluminium et roues pour un déplacement facile ou un changement de place. Boiserie modulaire pour être utilisée dans toutes les solutions d'ameublement.

Die Sommier-Modelle sind mit Füßen aus Aluminium erhältlich, die mit Rädern ausgestattet sind, damit sie leicht bewegt oder umgestellt werden können. Die Boiserie (Täfelung) ist modular zusammenstellbar, sodass sie sich in jedem Ambiente einsetzen lässt.

# Version Sommy Ocean





Un programma pratico e versatile. Gli stessi due sommieri possono diventare un angolo giorno living, una camera a due letti singoli o una camera con letto matrimoniale.

A practical and versatile program: the same two boxsprings can become a living corner for the day a bedroom with two single beds a bedroom with a queen bed.

Une solution pratique et versatile: les deux sommiers peuvent devenir un coin séjour une chambre à deux lits 1 place une chambre à un lit 2 places.

Ein praktisches und vielseitiges Programm. Die beiden Sommer-Elemente können zu einer Wohnzimmerecke, zu einem Schlafzimmer mit zwei Einzelbetten oder mit einem Doppelbett werden.





Per il blocco e lo sblocco dei piani letto nelle diverse versioni, un sistema semplice, robusto e veloce con cinghie e fibbie a scatto. Pratici piani di appoggio ovali o rettangolari da posizionare a piacere.

For locking and unlocking the bed surface in different versions, a simple, robust and fast system with straps and buckles. Practical oval or rectangular bases to be placed at will.

Pour le blocage et le déblocage des bases lit, de différentes versions, un système simple, solide et rapide avec sangles et boucles. De pratiques plans d'appui ovales ou rectangulaires à placer où l'on veut.

Zum Ver- und Entriegeln der Liegeflächen in den verschiedenen Ausführungen gibt es ein einfaches, robustes und schnelles System mit Riemen und einrastenden Schnallen. Praktische ovale oder rechteckige Ablageflächen, die nach Belieben platziert werden können.



Il piano letto del sommier per il sostegno del materasso in questa versione è realizzato in tessuto 3d, il massimo per la traspirazione del materasso e per il controllo termico. Massimo comfort, igiene e praticità.

In this version, the box spring's top for supporting the mattress is made of 3D fabric, the top for the transpiration of the mattress and for thermal control. Maximum comfort, hygiene and convenience.

La base du sommier pour le soutien du matelas dans cette version est réalisée en tissu 3D, idéal pour la transpiration du matelas et pour le contrôle thermique. Confort maximal, hygiène et commodité.

Die Matratzenstützfläche des Sommer-Betts besteht bei dieser Version aus 3D-Stoff, der die Matratze atmen lässt und für die Wärmeregulierung am besten geeignet ist. Maximaler Komfort, Hygiene und Zweckmäßigkeit.

# Ring Sommy - Sky/Ocean

COMPLETAMENTE SFODERABILE / COMPLETELY REMOVABLE FABRIC / COMPLÈTEMENT DÉHOUSSABLE / VOLLSTÄNDIG ABZIEHBAR

**MASSELLI** in legno di abete e/o scatolati in multistrato di legno di pino.

**PANNELLI** da 18/25 mm in particelle di legno di pino in classe E1 a bassa emissione di formaldeide e fibra di legno naturale.

**ESPANSI** di poliuretano indeformabile a portanza differenziata, densità da 18 kg/mc a 40 kg/mc.

**PRIMO RIVESTIMENTO** in espanso di poliestere accoppiato a caldo a vellutino aggrappante in poliestere e/o ovatta di poliestere al 100% da 200gr.

**FORGINGS** fir wood, and/or boxed in poplar plywood.

**Panels** 18/25 mm in poplar wood particles class E1 low formaldehyde emission and natural wood fiber.

**POLYURETHANE FOAM**, crushproof, of different capacity, density from 18 kg/mc to 40 kg/mc.

**FIRST COATING** hot bonded polyester foam, velvet adhesion in polyester and/or 100% polyester wool, 200gr.

**TIGE** en pin et/ou boitiers en multicouche en bois de peuplier.

**PANNEAUX** de 18/25 mm en particules de bois de peuplier classe E1 à faible émission de formaldéhyde et fibre de bois naturelle.

**POLYURÉTHANE EXPANSÉ** indéformable à portée différenciée, densité de 18kg/m<sup>3</sup> à 40kg/m<sup>3</sup>.

**PREMIER REVÊTEMENT** en polyester expansé accouplé à chaud à un velours accrochant en polyester et/ou ouate de polyester à 100% de 200g.

**MASSIVES** Tannenholz und/oder Blöcke aus Pappelmehrschichtholz.

**SPANPLATTEN** aus Pappelholz mit 18/25 mm Schichtdicke der Klasse E1, geringer Formaldehydabgabe und natürlichen Holzfasern.

**PolyurethanSCHAUM**, formbeständig und mit differenzierter Tragfähigkeit, Dichten von 18 kg/m<sup>3</sup> bis 40 kg/m<sup>3</sup>.

**ERSTER ÜBERZUG** aus Polyesterschaum, der auf Polyester-Samt und/oder 100% Polyesterwatte (zu 200 g) heiß aufkaschiert wurde.

**BODENPLATTEN** des Bettkastens aus 12-14 mm starken Spanplatten aus Pappelholz der Klasse E1.

## Ring Sommy Sky

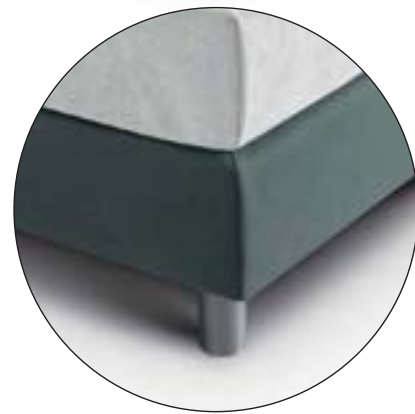

## Ring Sommy Ocean



## Ring Sommy - Sky

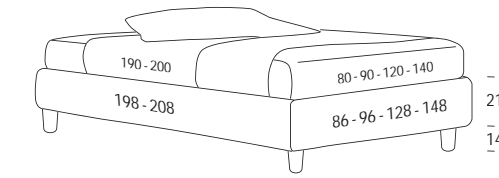

### Standard 2 PALACE H 14



Wengé / Wengé  
/ Wengé / Wengé

### Optional 2 PALACE H 14

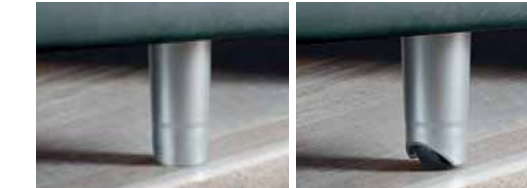

Alluminio / Aluminium  
/ Aluminium / Aluminium

con ruote antistruciolo  
with small wheels  
avec roulettes anti-trace  
mit rutschfesten Rädern

con ruote antistruciolo  
with small wheels  
avec roulettes anti-trace  
mit rutschfesten Rädern

## Ring Sommy - Ocean

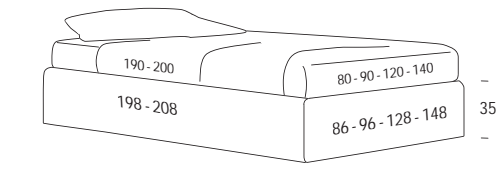

Due piedi in ABS (H 4 cm) e due piccole ruote antiraccia (H 4 cm)  
Two feet in ABS (H 4 cm) and two small wheels (H 4 cm)  
Deux pieds en ABS (H 4 cm) et deux petites roues anti-couissement (H 4 cm)  
Zwei Füße aus ABS (H 4 cm) und zwei kleine Räder (H 4 cm), die keine Spuren hinterlassen

# Erik



IL LETTO CHE  
CERCAVI,  
ORA LO CREI TU.

THE BED YOU WERE  
LOOKING FOR  
WILL BE YOUR OWN.

LE LIT QUE VOUS  
CHERCHIEZ,  
CRÉEZ LE VOUS-MÊME  
MAINTENANT.

DAS BETT, DAS  
SIE SCHON IMMER  
SUCHTEN,  
STELLEN SIE JETZT  
SELBST ZUSAMMEN.



# Scegli il tuo modello

Choose your model  
 Choisissez votre modèle  
 Wählen Sie Ihr Modell



**Le 1000 possibilità del programma letto singolo** molto versatile grazie agli ingombri contenuti è utilizzabile per il contract, per il privato, a centrostanza o anche nelle armadiature a ponte o per arredare spazi contenuti.

**Per l'estetica:** dal sommier base tutte le possibilità di testiere / fianchi / pediere.  
**Per la praticità:** contenitori con alzata assistita della rete o estraibili.

**Per la funzionalità:** letto singolo, due singoli, matrimoniale con estrazione automatica o semiautomatica del secondo letto.

**The 1000 possibilities of the single bed program** very versatile and compact, suitable for the contract, for private spaces, for the center of the room or even in suspended cupboards or for decorating small spaces.

**For aesthetics** from the basic box spring all the possibilities for headboards / sides / footboards.

**For practicality** containers with assisted lift of the support or removable.

**For functionality** single bed, double bed, queen bed, with automatic or semi-automatic extraction of the second bed.

**Les 1000 possibilités de lits 1 place** très versatile grâce à un faible encombrement utilisable pour l'hôtellerie ou le particulier, au centre de la pièce ou dans des armoires à pont ou pour meubler des espaces exigus.

**Pour l'esthétique** du sommier base toutes les possibilités de tête de lit/côtés/pied de lit.

**Pour la commodité** des coffres de rangement avec soulèvement assisté du sommier ou extractible.

**Pour la fonctionnalité** lit 1 place, deux lit 1 places, lit 2 places avec extraction deuxième lit automatique ou semi-automatique.

**Die 1000 Möglichkeiten des Einzelbettprogramms** sind dank des geringen Platzbedarfs sehr vielseitig und können sowohl im Hotel als auch privat, in der Mitte des Raumes, mit Bettbrücken oder zur Einrichtung kleiner Räume eingesetzt werden.

**Für ein gutes Aussehen:** ausgehend vom Sommer-Basismodell sind alle Kopf-/Seiten-/Fußteile möglich.

**Für mehr Zweckmäßigkeit:** Bettkasten mit Bettenrost-Anhebehilfe oder ausziehbar.

**Für mehr Funktionalität:** Einzelbett, zwei Einzelbetten, Doppelbett mit automatischem oder halbautomatischem Auszug des zweiten Bettes.

Art. 01

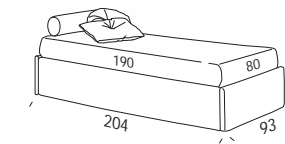

Art. 03

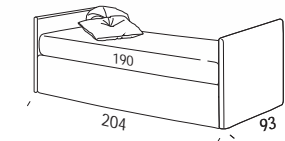

Art. 05

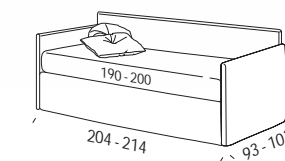

Art. 02

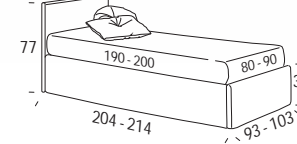

Art. 04

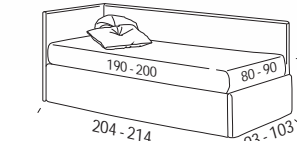

Art. 06

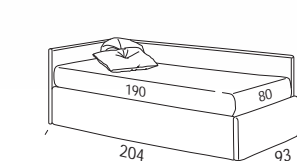

Disponibile anche nella versione MAXI L. 90 P. 200  
 Also available in version MAXI L. 90 P. 200  
 Disponible aussi en version MAXI L. 90 P. 200  
 Auch in der Ausführung MAXI B. 90 T. 200 erhältlich

Disponibile anche nella versione MAXI L. 90 P. 200  
 Also available in version MAXI L. 90 P. 200  
 Disponible aussi en version MAXI L. 90 P. 200  
 Auch in der Ausführung MAXI B. 90 T. 200 erhältlich

Disponibile anche nella versione MAXI L. 90 P. 200  
 Also available in version MAXI L. 90 P. 200  
 Disponible aussi en version MAXI L. 90 P. 200  
 Auch in der Ausführung MAXI B. 90 T. 200 erhältlich

Art. 07

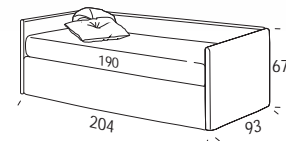

Art. 09

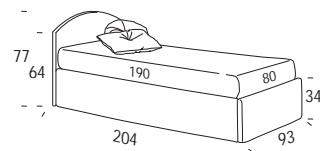

Art. 11

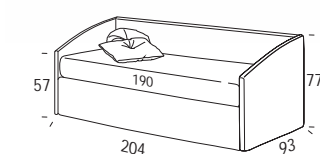

Art. 08 DX/SX Disponibile anche nella versione MAXI L.90 P.200  
Also available in version MAXI L.90 P.200  
Disponibile aussi en version MAXI L.90 P.200  
Auch in der Ausführung MAXI B.90 T.200 erhältlich

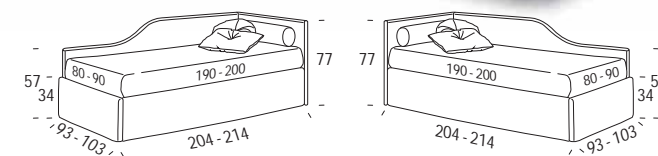

Art. 08 DX

Art. 80 SX

Art. 10

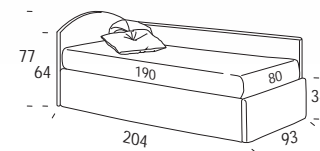

Art. 12 DX/SX

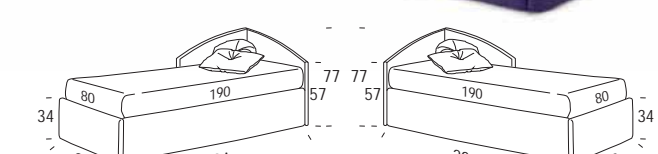

Art. 12 DX

Art. 21 SX

## Trova la soluzione che preferisci

Find the solution preferred  
Trouvez la solution que vous préférez  
Finden Sie die von Ihnen bevorzugte Lösung



### SOLUZIONE K contenitore

**CASSETTONE ESTRAIBILE.**  
Un pratico contenitore per recuperare spazio e fare ordine in camera liberando gli armadi.  
**REMOVABLE DRAWER.**  
A practical storage space to save space and put the room in order emptying the wardrobes.  
**GRAND TIROIR EXTRACTIBLE.**  
Un conteneur pratique pour récupérer espace et mettre de l'ordre dans la chambre à coucher en libérant les armoires.  
**AUSZIEHBARE SCHUBLADE.**  
Ein praktischer Stauraum für mehr Platz und Ordnung im Zimmer, belässt mehr Platz im Schrank.



### SOLUZIONE X contenitore

**CONTENITORE APERTURA RETE.**  
Con un semplice movimento il letto si alza per scoprire un vano per lenzuola, coperte e qualsiasi altra necessità.  
**FRAME OPENING STORAGE SPACE.**  
With an easy movement the bed lifts up to discover a compartment for linen, blankets and more.  
**CONTENEUR AVEC OUVERTURE SOMMIER.**  
Par un simple geste le lit se lève pour découvrir un compartiment pour ranger draps, couvertures et quelque chose d'autre nécessaire.  
**BETTKASTEN MIT BETTENROST-ANHEBUNG.**  
Mit einer einfachen Bewegung hebt sich das Bett an und gibt ein Fach für Bettlaken, Decken und andere Dinge frei.



### SOLUZIONE Y 2° letto

**LETTO SUPPLEMENTARE CON APERTURA SEMI-AUTOMATICA.**  
Tutta la comodità di un posto letto in più, anche in ambienti contenuti. Completo di materasso L.76 P.180 H.15 cm.  
**ADDITIONAL BED WITH SEMI-AUTOMATIC OPENING.**  
The convenience of an extra bed, even in reduced spaces. Equipped with a mattress L.76, D.180, H.15 cm.  
**LIT SUPPLÉMENTAIRE AVEC OUVERTURE SEMI-AUTOMATIQUE.**  
Tout le confort d'un lit en plus, même dans des milieux petits. Complet de matelas L. 76 P. 180 H. 15 cm.  
**ZUSÄTZLICHES BETT MIT HALBAUTOMATISCHER ÖFFNUNG.**  
Der ganze Komfort eines zusätzlichen Bettes, auch in kleinen Zimmern. Komplett mit Matratze B.76 T.180 H.15 cm.



### SOLUZIONE Z 2° letto

**LETTO SUPPLEMENTARE CON APERTURA AUTOMATICA.**  
Basta una mossa per alzare il letto. Con testata integrata per appoggiare il cuscino.  
Completo di materasso L.76 P.180 H.15 cm.  
**ADDITIONAL BED WITH AUTOMATIC OPENING.**  
Just a move to lift the bed. Built-in headboard to place the cushion.  
Equipped with mattress L.76 D.180 H.15 cm.  
**LIT SUPPLÉMENTAIRE AVEC OUVERTURE AUTOMATIQUE.**  
Il ne suffit qu'un simple geste pour soulever le lit. Avec tête de lit intégrée pour appuyer le coussin.  
Complet de matelas L.76 P.180 H.15 cm.  
**ZUSÄTZLICHES BETT MIT AUTOMATISCHER ÖFFNUNG.**  
Zum Anheben des Bettes reicht ein einziger Handgriff. Mit integriertem Kopfteil zum Anlehnen des Kissens.  
Komplett mit Matratze B.76 T.180 H.15 cm.

Di serie con materasso H.15 allineato  
As standard with aligned mattress H.15  
De série avec matelas H. 15 aligné  
Serienmäßig mit ausgerichteteter Matratze H.15

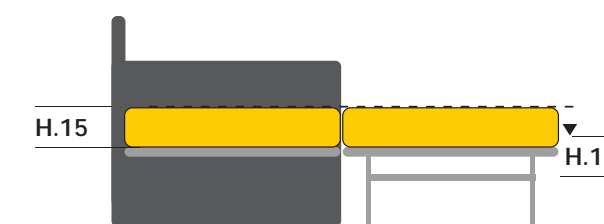

Materassi allineati  
Aligned mattresses  
Matelas alignés  
Ausgerichtete Matratzen

Totamente in espanso indeformabile 26 NY P.3,6  
Totally crushproof polyurethane foam 26 NY P. 3,6  
Complètement en expansé indéformable 26 NY P. 3,6  
Vollständig aus formstabilem Schaum 26 NY T.3,6

**Maggiorazione coprimaniglione per rete estraibile automatica**  
Handle cover surcharge for automatic removable frame  
Augmentation de prix pour un couvre-poignée pour sommier extractible automatique  
Aufschlag Griffabdeckung für automatisch ausziehbaren Bettenrost

N.B. NELLA VERSIONE A RICHIESTA CON RETE SUPERIORE L.90 P.200 IL 2° LETTO HA MATERASSO L.86 P.190 H.15  
N.B. IN THE VERSION ON DEMAND WITH UPPER FRAME L.90 D.200. THE MATTRESS OF THE SECOND BED IS L.86 D.190 H.15  
N.B. SUR DEMANDE DANS LA VERSION AVEC SOMMIER SUPÉRIEUR L.90 P.200 LE 2° LIT A UN MATELAS L.86 P. 190 H.15  
Bitte beachten: IN DER VERSION AUF ANFRAGE MIT OBEREM BETTENROST B.90 T.200 HAT DAS 2. BETT EINE MATRATZE MIT B.86 T.190 H.15





# Completa il tuo comfort

Complete your comfort

Complétez votre confort

Vervollständigen Sie Ihren Komfort

Lasciati conquistare dai comodi optional, per un relax e uno stile senza paragoni.

Let yourself be seduced by comfortable optionals for an unmatched relax and style.

Laissez-vous conquérir par des options confortables, pour un relax et un style sans comparaisons.

Lassen Sie sich von den komfortablen Optionen erobern, die für unvergleichliche Entspannung und Stil sorgen.



BENNY 50x35 cm



CONNY 40x40 cm



BENNY Ø50 cm



CLYDE 60x18 cm

## TRAPUNTA



## TRAPUNTA MAXI



(per letti versioni MAXI e per materassi superiori H.20)  
(for MAXI versions beds and mattresses exceeding H.20)  
(pour les lits version MAXI et pour les matelas supérieurs à H. 20)  
(Für Betten der MAXI Version und für Matratzen höher als H.20)

**OPTIONAL: MATERASSO SUPERIORE H.20**  
Totalmente in espanso indeformabile 26 NY P.3,6  
VERSIONE L. 80 P.190  
VERSIONE MAXI L. 90 P.200

**OPTIONAL: MATTRESS EXCEEDING H.20**  
Totally crushproof polyurethane foam 26 NY P.3,6  
VERSION L. 80 D.190  
MAXI VERSION L. 90 D.200

**OPTION: MATELAS SUPERIEUR À H. 20**  
Complètement en expansé indéformable 26 NY P. 3,6  
VERSION L. 80 P. 190  
VERSION MAXI L. 90 P. 200

**OPTIONAL: OBERE MATRATZE H.20**  
Vollständig aus formstabilem Schaum 26 NY T.3,6  
VERSION B.80 T.190  
MAXI VERSION B.90 T.200

**ATTENZIONE OPTIONAL MATERASSO H. 20 / ATTENTION: OPTIONAL MATTRESS H.20**  
/ ATTENTION OPTION MATELAS H. 20 / ACHTUNG OPTIONAL MATRATZE H.20

Non allineati in caso di soluzione con 2° letto / Not aligned in case of option with second bed  
/ Non alignés en cas de solution avec 2e lit / Nicht ausgerichtet im Fall der Lösung mit 2. Bett

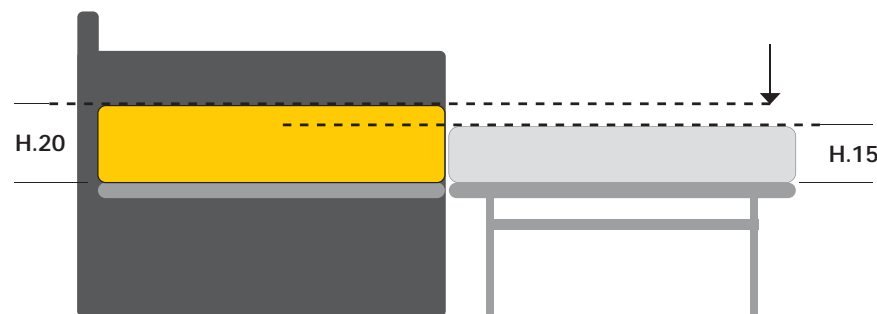

## OPTIONAL SET CUSCINI SCHIENA-DIVANO

OPTIONAL: SET OF CUSHIONS BACK-SOFA

OPTION SET COUSSINS DOSSIER-CANAPÉ

OPTIONALES SET RÜCKEN-SOFA-KISSEN

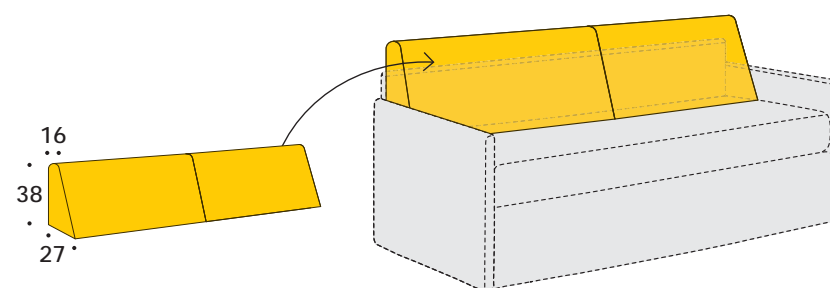

# Erik

COMPLETAMENTE SFODERABILE / COMPLETELY REMOVABLE FABRIC / COMPLÈTEMENT DÉHOUSSABLE / VOLLSTÄNDIG ABZIEHBAR

## RETE

Meccanica con tubolare d'acciaio a sezione quadra verniciata con polveri epossidiche e dotata di meccanismo testato dal nostro ufficio tecnico per oltre 2.000 cicli di apertura. Il piano dormita supporta il peso di due persone adulte di peso medio senza deformarsi.

## TELAIO

Realizzato con masselli di abete in vari spessori, parti di tamponamento in fibra di legno e/o compensato, fianchi in agglomerato di legno da 18 mm. Fibra grezza e/o agglomerato di legno a bassa emissione di formaldeide, il tutto rivestito con vellutino 100% poliammide termoaccoppiato ad espanso di poliesteri e/o ovatta di poliesteri 100% da 200gr.

## IMBOTTITURA

Seduta: materasso in espanso indeformabile in densità 25E. Rivestimento in fibra poliesteri 100gr con tessuto essenziale bianco fascia perimetrale 3D. Schienale in espanso indeformabile densità 18S rivestito in poliesteri 200g. Braccioli in fiocco siliconato rivestito in T.N.T.

## BEDFRAME

Mechanism with square stainless steel tubing epoxy painted tested by our engineering department up to more than 2.000 cycles of opening. The sleep top supports the weight of two medium-weight adult people without warping.

## FRAME

Made of forgings fir wood in various thicknesses, wood fibre and/or plywood infill parts, particle wood sides 18 mm. Raw fibre and/or wooden agglomerate at low formaldehyde emissions. Everything is coated in 100% thermo-coupled polyamide velvet in polyester foam and/or 100% polyester wadding of 200gr.

## PADDING

Seat: mattress in crushproof polyurethane foam, density 25E. Cover in polyester fibre 100gr with essential white fabric of the boundary band 3D. Backrest in crushproof polyurethane foam, density 18S polyester covered 200gr. Armrests in silicon staple fibre covered with T.N.T.

## SOMMIER

Mécanisme avec tubulaire en acier à section carrée vernie aux poudres époxydes et dotée de mécanisme testé dans notre bureau technique par plus de 2.000 cycles d'ouverture. Le plan sommeil supporte le poids de deux personnes de poids moyen sans se déformer.

## STRUCTURE

Réalisé en pin massif de différentes épaisseurs, partie de bande de remplissage en fibre de bois et/ou compensé, côtés en bois aggloméré de 18 mm. Fibre brute et/ou en bois aggloméré à basse émission de formaldéhyde, le tout revêtu par du velours 100% polyamide thermo-accouplé avec du polyester expansé et/ou 200 gr. de ouate 100% polyester.

## REMBOURRAGE

Assise: matelas en expansé indéformable en densité 25E. Revêtement en fibre de polyester 100 gr. avec tissu essentiel blanc bande périmétrique 3D. Dossier en expansé indéformable densité 18S revêtu en polyester 200 gr. Accoudoirs en fleur siliconée revêtue en T.N.T.

## BETTENROST

Struktur aus Stahlrohr mit quadratischem Querschnitt, mit Epoxidpulver lackiert und mit einem Mechanismus ausgestattet, der von unserer technischen Abteilung auf über 2.000 Öffnungszyklen getestet wurde. Die Liegefläche trägt das Gewicht von zwei Erwachsenen mittleren Gewichts, ohne sich zu verformen.

## RAHMEN

Aus massivem Tannenholz in verschiedenen Stärken, Füllungen aus Holzfasern und/oder Sperrholz, 18 mm Spanplatten an den Seiten. Rohfaser und/oder Spanplatte mit geringer Formaldehydabgabe: all dies ist mit Samt aus 100% Polyamid bezogen, der mit Polyesterschaum und/oder Watte aus 100% Polyester zu 200g heiß aufkaschiert wurde.

## POLSTERUNG

Sitzfläche: Matratze aus formbeständigem Schaum in Dichte 25E. Bezug aus Polyesterfaser zu 100g mit weißem Stoff und umlaufendem 3D-Streifen. Rückenlehne aus formbeständigem Schaum der Dichte 18S aus Polyester zu 200g. Armlehnen aus silikonbeschichteter Stapelfaser mit Vliesstoffbezug.



# Houdini



**Pouf letto**  
 Con il minimo ingombro la possibilità di un posto letto in più. Semplice e veloce. Si estrae frontalmente e si solleva dai lati per ottenere un unico morbido piano letto. Come tutte le proposte Felis completamente sfoderabile.

**Bed ottoman**  
 In a small size the possibility of an extra bed. Simple and fast. It is extracted on the front and lifted from the sides to obtain a single soft bed top. Like all proposals by Felis, it is completely removable.

**Pouf lit**  
 Avec peu d'encombrement possibilité d'avoir un lit supplémentaire. Simple et rapide. Il s'extrait de face et se soulève par les côtés pour obtenir un lit moelleux comme toutes les propositions Felis il est entièrement déhoussable.

**Schlafhocker**  
 Die Möglichkeit eines zusätzlichen Bettes bei minimalem Platzbedarf. Einfach und schnell. Wird vorne herausgezogen und seitlich angehoben, um so ein weiches Einzelbett zu erhalten. Wie alle Produkte von Felis vollständig abziehbar.

## Houdini

COMPLETAMENTE SFODERABILE / COMPLETELY REMOVABLE FABRIC / COMPLÈTEMENT DÉHOUSSABLE / VOLLSTÄNDIG ABZIEHBAR

**MASSELLI** in legno di abete e/o scatolati in multistrato di legno di pioppo.  
**PANNELLI** da 18/25 mm in particelle di legno di pioppo in classe E1 a bassa emissione di formaldeide e fibra di legno naturale.  
**ESPANSI** di poliuretano indeformabile a portanza differenziata, densità da 18 kg/mc a 40 kg/mc.  
**PRIMO RIVESTIMENTO** in espanso di poliesteri accoppiato a caldo a vellutino aggrappante in poliesteri e/o ovatta di poliesteri al 100% da 200gr.  
**POUF** dotato di 4 ruote con gomma antisdrucciolo.

**FORGINGS** fir wood, and/or boxed in poplar plywood.  
**PANELS** 18/25 mm in poplar wood particles class E1 low formaldehyde emission and natural wood fiber.  
**POLYURETHANE FOAM**, crushproof, of different capacity, density from 18 kg/mc to 40 kg/mc.  
**FIRST COATING** hot bonded polyester foam, velvet adhesion in polyester and/or 100% polyester wool, 200gr.  
**POUF** with four small wheels with anti-slip system.

**TIGE** en pin et/ou boitiers en multicouche en bois de peuplier.  
**PANNEAUX** de 18/25 mm en particules de bois de peuplier classe E1 à faible émission de formaldéhyde et fibre de bois naturelle.  
**POLYURÉTHANE EXPANSÉ** indéformable à portée différenciée, densité de 18kg/m<sup>3</sup> à 40kg/m<sup>3</sup>.  
**PREMIER REVÊTEMENT** en polyester expansé accouplé à chaud à un velours accrochant en polyester et/ou ouate de polyester à 100% de 200g.  
**POUF** avec quatre roulettes avec gomme antiglisse.

**MASSIVES** Tannenholz und/oder Blöcke aus Pappelmehrschichtholz.  
**SPANPLATTEN** aus Pappelholz mit 18/25 mm Schichtdicke der Klasse E1, geringer Formaldehydabgabe und natürlichen Holzfasern.  
**PolyurethanSCHAUM**, formbeständig und mit differenzierter Tragfähigkeit, Dichten von 18 kg/m<sup>3</sup> bis 40 kg/m<sup>3</sup>.  
**ERSTER ÜBERZUG** aus Polyesterschaum, der auf Polyester-Samt und/oder 100% Polyesterwatte (zu 200 g) heiß aufkaschiert wurde.  
**SITZPUFF** mit 4 Rädern aus rutschfestem Gummi.

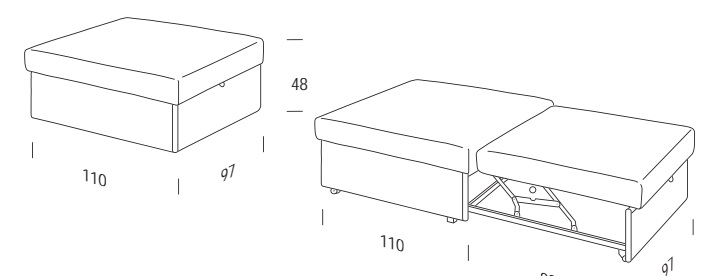

# Boiserie Collection



Sette moduli per infinite soluzioni. La boiserie modulare è combinabile a piacere e può essere attrezzata con piani di appoggio di forma ovale e rettangolare, facilmente inseribili senza alcun fissaggio.

Seven modules for endless solutions. The modular boiserie can be freely combined and may be equipped with oval and rectangular table tops, easily inserted without fixing.

Sept modules pour des solutions infinies. La boiserie modulaire se combine selon les choix et peut être équipée par des plans d'appui de forme ovale et rectangulaire, à insérer facilement sans aucune fixation.

Sieben Module für unendlich viele Lösungen. Die modulare Boiserie ist beliebig kombinierbar und kann mit ovalen und rechteckigen Ablageflächen bestückt werden, die sich einfach und ohne jegliche Befestigung einfügen lassen.



H. 35 cm / P.D.P. 7 cm

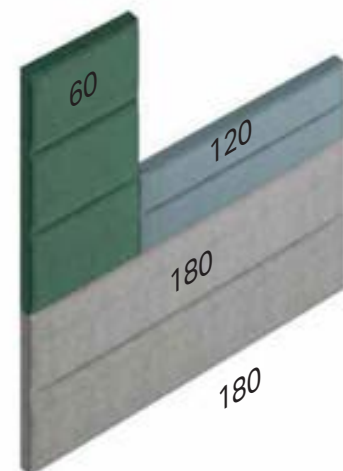
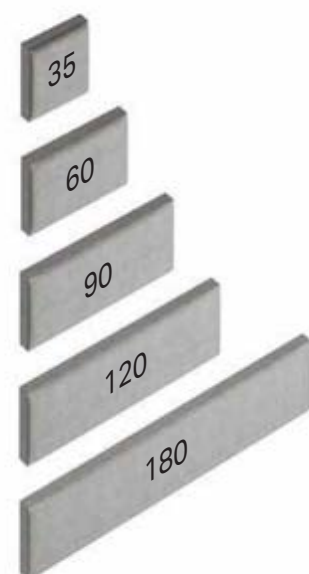

H. 17,5 cm / P.D.P. 7 cm

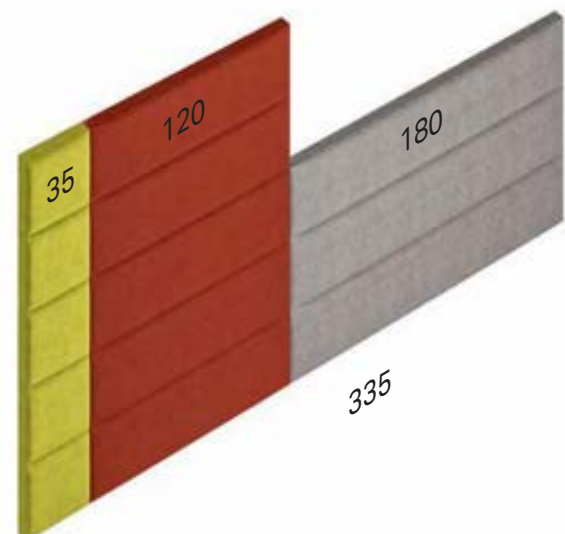

7 moduli per infinite soluzioni.  
I moduli della boiserie componibile.

7 modules for endless solutions.  
The modules of the wall panels.

7 modules pour une infinités de solutions. Les éléments de la boiserie sont modulaires.

7 Module für unendlich viele Lösungen. Die Module der zusammenstellbaren Boiserie

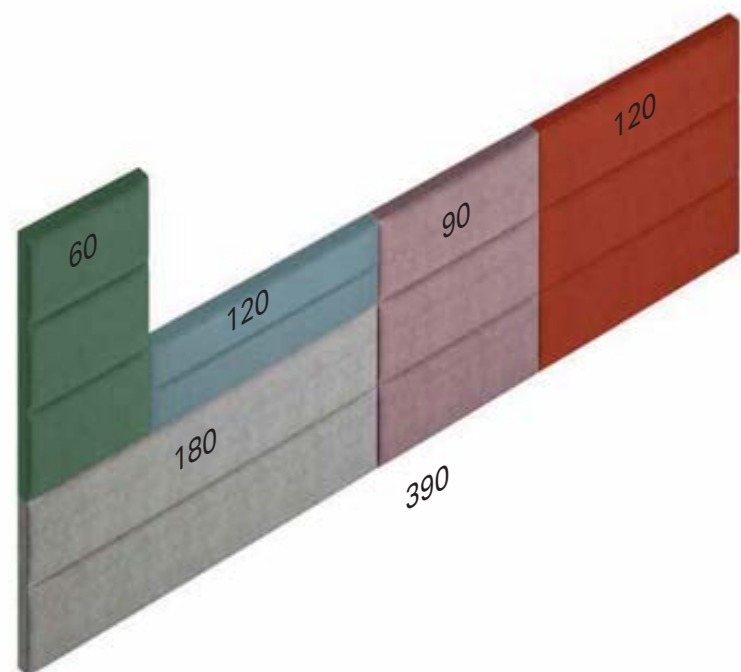

LIVING

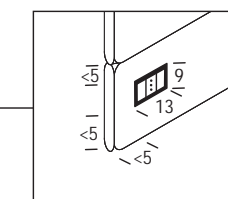

Predisposizione scatola a incasso tipo 503  
Predisposition recessed box type 503  
Boîte encastrée prédisposition type 503  
Veranlagung Einbaubox Typ 503

BEDROOM



CONTRACT



STUDIO



RELAX



# Panquette Collection



## Panquette contenitore

COMPLETAMENTE SFODERABILE / COMPLETELY REMOVABLE FABRIC / COMPLÈTEMENT DÉHOUSSABLE / VOLLSTÄNDIG ABZIEHBAR

**MASSELLI** in legno di abete e/o sciolati in multistrato di legno di pioppo.  
**PANNELLI** da 18/25 mm in particelle di legno di pioppo in classe E1 a bassa emissione di formaldeide e fibra di legno naturale.  
**ESPANSI** di poliuretano indeformabile a portanza differenziata, densità da 18 kg/mc a 40 kg/mc.  
**PRIMO RIVESTIMENTO** in espanso di poliesteri accoppiato a caldo a vellutino aggrappante in poliesteri e/o ovatta di poliesteri al 100% da 200gr.

**FORGINGS** fir wood, and/or boxed in poplar plywood.  
**PANELS** 18/25 mm in poplar wood particles class E1 low formaldehyde emission and natural wood fiber.  
**POLYURETHANE FOAM**, crushproof, of different capacity, density from 18 kg/mc to 40 kg/mc.  
**FIRST COATING** hot bonded polyester foam, velvet adhesion in polyester and/or 100% polyester wool, 200gr.

**TIGE** en pin et/ou boitiers en multicouche en bois de peuplier.  
**PANNEAUX** de 18/25 mm en particules de bois de peuplier classe E1 à faible émission de formaldéhyde et fibre de bois naturelle.  
**POLYURÉTHANE EXPANSÉ** indéformable à portée différenciée, densité de 18kg/m<sup>3</sup> à 40kg/m<sup>3</sup>.  
**PREMIER REVÊTEMENT** en polyester expansé accouplé à chaud à un velours accrochant en polyester et/ou ouate de polyester à 100% de 200g.

**MASSIVES** Tannenholz und/oder Blöcke aus Pappelholzschichtholz.  
**SPANPLATTEN** aus Pappelholz mit 18/25 mm Schichtdicke der Klasse E1, geringer Formaldehydabgabe und natürlichen Holzfasern.  
**PolyurethanSCHAUM**, formbeständig und mit differenzierter Tragfähigkeit, Dichten von 18 kg/m<sup>3</sup> bis 40 kg/m<sup>3</sup>.  
**ERSTER ÜBERZUG** aus Polyester-Samt und/oder 100% Polyesterwatte (zu 200 g) heiß aufkaschiert wurde.

<b>Art. 01</b>	<b>Art. 02</b>	<b>Art. 03</b>	<b>Art. 04</b>	<b>Art. 05</b>	<b>Art. 06</b>
Liscio Smooth Lisse	Bordo Edge Bord	Pizzicato 0,5 Pinched 0,5 Pincé 0,5	Ripreso + Bordo Gathered + Trim Reprise + Bord	Bordo + Gonna Trim + Valance Jupe + Bord	Ripreso + Gonna Gathered + Valance Jupe + Reprise
<b>Standard BASIC H 3</b>	<b>Optional LUX H 3</b>	<b>Optional VISUAL H 9</b>	<b>Optional CLASSIC H 5</b>	<b>Pag 545</b>	
Wengé / Wengé / Wengé / Wengé	Wengé / Wengé / Wengé / Wengé	Wengé / Wengé / Wengé / Wengé	Wengé / Wengé / Wengé / Wengé	<b>Vano utile 90l</b> Compartment usable 90l Compartment utile 90l Nutzbares Volumen des Fachs 90l	
Nero / Black / Noir / Schwarz	Nero / Black / Noir / Schwarz	Nero / Black / Noir / Schwarz	Bianco / White / Blanc / Weiß		
Argento / Silver / Argent / Silber	Cromo / Chrome / Chrome / Chrom	Argento / Silver / Argent / Silber	Argento / Silver / Argent / Silber		
Bianco / White / Blanc / Weiß	Bianco / White / Blanc / Weiß	Bianco / White / Blanc / Weiß	Bianco / White / Blanc / Weiß		



## Panquette nuvola

COMPLETAMENTE SFODERABILE / COMPLETELY REMOVABLE FABRIC / COMPLÈTEMENT DÉHOUSSABLE / VOLLSTÄNDIG ABZIEHBAR

**MASSELLI** in legno di abete e/o scatolati in multistrato di legno di pioppo.  
**PANNELLI** da 18/25 mm in particelle di legno di pioppo in classe E1 a bassa emissione di formaldeide e fibra di legno naturale.  
**ESPANSI** di poliuretano indeformabile a portanza differenziata, densità da 18 kg/mc a 40 kg/mc.  
**PRIMO RIVESTIMENTO** in espanso di poliester accoppiato a caldo a vellutino aggrappante in poliester e/o ovatta di poliester al 100% da 200gr.

**FORGINGS** fir wood, and/or boxed in poplar plywood.  
**PANELS** 18/25 mm in poplar wood particles class E1 low formaldehyde emission and natural wood fiber.  
**POLYURETHANE FOAM**, crushproof, of different capacity, density from 18 kg/mc to 40 kg/mc.  
**FIRST COATING** hot bonded polyester foam, velvet adhesion in polyester and/or 100% polyester wool, 200gr.

**TIGE** en pin et/ou boitiers en multicouche en bois de peuplier.  
**PANNEAUX** de 18/25 mm en particules de bois de peuplier classe E1 à faible émission de formaldéhyde et fibre de bois naturelle.  
**POLYURÉTHANE EXPANSÉ** indéformable à portée différenciée, densité de 18kg/m<sup>3</sup> à 40kg/m<sup>3</sup>.  
**PREMIER REVÊTEMENT** en polyester expansé accouplé à chaud à un velours accrochant en polyester et/ou ouate de polyester à 100% de 200g.

**MASSIVES** Tannenholz und/oder Blöcke aus Pappelmehrschichtholz.  
**SPANPLATTEN** aus Pappelholz mit 18/25 mm Schichtdicke der Klasse E1, geringer Formaldehydabgabe und natürlichen Holzfasern.  
**PolyurethanSCHAUM**, formbeständig und mit differenzierter Tragfähigkeit, Dichten von 18 kg/m<sup>3</sup> bis 40 kg/m<sup>3</sup>.  
**ERSTER ÜBERZUG** aus Polyesterschaum, der auf Polyester-Samt und/oder 100% Polyesterwatte (zu 200 g) heiß aufkaschiert wurde.

Art. 01 M

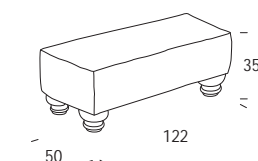

Liscio  
Smooth  
Lisse

Art. 02 N

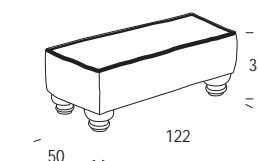

Bordo  
Edge  
Bord

Art. 03 P

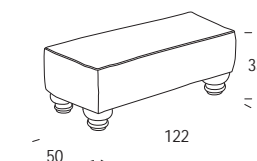

Pizzicato 0,5  
Pinched 0,5  
Pincé 0,5

Art. 04 R

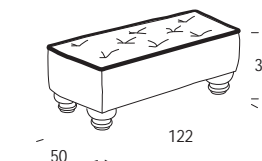

Ripreso + Bordo  
Gathered + Trim  
Reprise + Bord

Standard **BLADEH** 13



Satinato / Satin  
/ Satiné / Satiniert

Optional **TOWER** H 13



Optional **MOZART** H 13



Wengé / Wengé / Wengé / Wengé

Pag 545

**BLADE** H 13 Pag 546



Bronzato / Bronze  
/ Bronze / Bronziert

Optional **PLEXY** H 13



Bianco / White / Blanc / Weiß



Argento / Silver / Argent / Silber



Oro / Gold / Or / Gold

# Optional Info. tech.

In queste pagine, un riepilogo generale dell'ampia gamma di optional disponibili per i diversi modelli, nell'ottica di facilitare la configurazione del letto che sappia soddisfare nel migliore dei modi le richieste di funzionalità e i gusti estetici di ciascuno.

In these pages a general overview of the wide range of optionals available for the various models, with a view to ease a configuration of the bed satisfying in the best way the demands for usability and aesthetic tastes of everyone.

Dans ces pages, un aperçu général du large éventail d'options disponibles pour les divers modèles en vue de faciliter la conception du lit pour satisfaire au mieux les besoins de praticité et les goûts esthétiques de chacun.

Auf diesen Seiten finden Sie eine allgemeine Übersicht über das umfassende Sortiment der für die verschiedenen Modelle erhältlichen Optionen, denn wir möchten unseren Kunden bei der Konfiguration des Betts behilflich sein, das den funktionellen Anforderungen und dem eigenen Geschmack am besten entspricht.

## Sacca porta oggetti

Storage bag  
Sac porte-objets  
Einstecktasche

Portaoggetti in tessuto.  
L.63 x H.47 cm

Per la rivista o il libro, per il tablet o il telefono, per l'astuccio degli occhiali o le cuffie. Un comodo portaoggetti in tessuto coordinato con il rivestimento del letto, una soluzione utile pratica ed elegante.

Fabric storage bag.  
L.63 x H.47cm

For magazines or books, tablets, or phones, for glass cases or headphones. A handy storage bag in fabric coordinated with the bed cover, a useful, practical, and elegant solution.

Porte-objets en tissu.  
L.63 x H.47cm

Pour une revue ou un livre, pour la tablette ou le téléphone, pour l'étui à lunettes ou les écouteurs. Un porte-objets pratique en tissu assorti au revêtement du lit, une solution utile, pratique et élégante.

Einstecktasche aus Stoff.  
B.63 x H.47 cm

Für eine Zeitschrift oder ein Buch, fürs Tablet oder Telefon, fürs Brillenetui oder Kopfhörer. Eine bequeme Einstecktaste aus Stoff, passend zum Bettbezug, eine praktische und elegante Lösung.



Disponibile per tutti i modelli  
Available for all models  
Disponibile pour tous les modèles  
Für alle Modelle erhältlich

## Illuminazione

Lighting  
Éclairage  
Beleuchtung

Una soluzione che libera spazio. Il punto luce, inglobato nella testiera, discreto ma efficiente perché proprio lì dove serve. Gli eventuali piani accanto al letto risultano così liberi per altri oggetti o superflui.

A solution that frees up space. The light point, incorporated into the headboard, discreet but efficient because it is right there where you need it. Any surfaces by the bed are thus free for other items or unnecessary.

Une solution qui libère l'espace. Une lampe incorporée dans la tête de lit discrète mais efficace parce qu'elle se trouve exactement là où il faut. Les surfaces à côté du lit sont libres pour d'autres objets ou sont superflues.

Eine platzsparende Lösung. Das ins Kopfteil integrierte Licht ist diskret, aber effizient, denn es befindet sich genau dort, wo es gebraucht wird. Eventuelle Ablageflächen neben dem Bett sind nun frei und bieten Platz für andere Gegenstände oder Krimskräms.



Le lampade inoltre non richiedono interruttori. Per l'accensione utilizza il tecnologico sistema touch, un semplice tocco delle dita direttamente sulla lampada per accendere e spegnere.

Moreover, the lamps do not require switches. For ignition, it uses the technological touch system, the touch of your fingers on the lamp turns it on and off.

Les lampes n'ont pas besoin d'interrupteurs. Pour les allumer il y a la technologie système "tactile", un simple toucher sur la lampe pour allumer et éteindre.

Die Lampen benötigen keine Schalter. Zum Einschalten kommt das technologische Touch-System zum Einsatz; eine einfache Berührung mit dem Finger direkt auf der Lampe reicht aus, um sie ein- und auszuschalten.

Disponibile per i modelli: Kevin - Penny  
Available for models: Kevin - Penny  
Disponibile pour les modèles: Kevin - Penny  
Für folgende Modelle erhältlich: Kevin - Penny



## Portagioie

Jewelry box  
Porte-bijoux  
Schmuckkästchen

Portagioie alla base della testiera.

Le piccole gioie, il telefono, l'orologio. Tanti piccoli oggetti che non vogliamo con noi durante il sonno possono trovare posto nei pratici portaoggetti ricavati alla base della testiera. Sempre a portata di mano, ma non esposti sul piano dei mobili della camera, riposti in modo più discreto.

Jewelry box at the base of the headboard.

Jewelery, the phone, the watch. So many small items we do not want on us during sleep may find their place in the practical compartments placed at the base of the headboard. Always at hand, but not exposed on the furniture of the room, placed in a more discreet location.

Porte-bijoux à la base de la tête de lit.

Les petits objets, le téléphone, la montre. Tant de petits objets que nous ne voulons pas avec nous pour dormir peuvent trouver leur place dans les porte-objets prévus à la base de la tête de lit. Toujours à portée de main, mais non exposés sur les meubles mais rangés de manière discrète.

Schmuckkästchen am Fuß des Kopfteils.

Für diversen Krimskrams, Telefon oder Armbanduhr. All die vielen kleinen Gegenstände, die uns nachts während des Schlafs stören würden, finden Platz in den praktischen Schmuckkästchen am Fuß des Kopfteils. Immer griffbereit, aber nicht auf den Schlafzimmern Möbeln herumliegend, sondern diskret aufbewahrt.

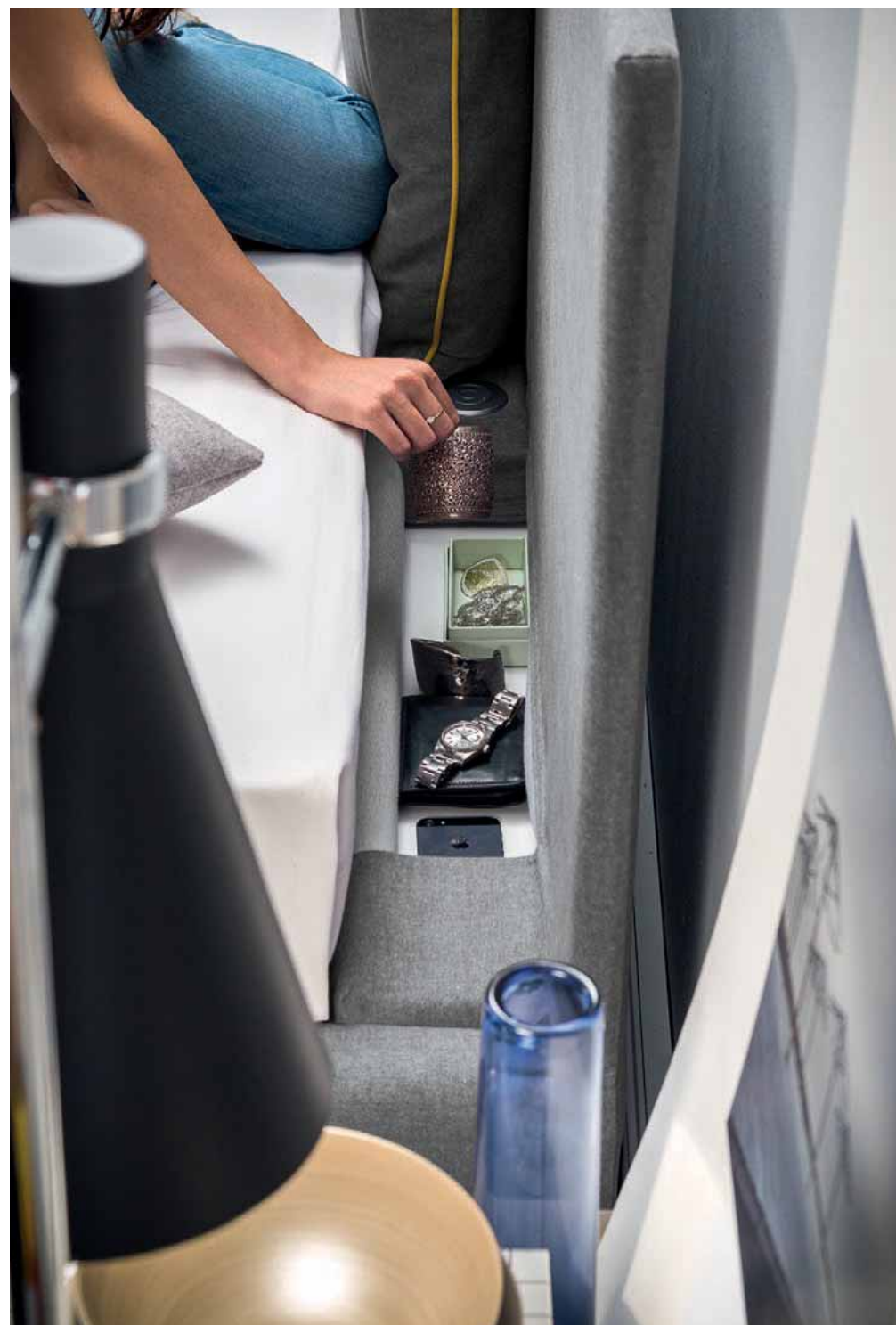

Disponibile per i modelli:  
Allen - Scotty - Edgar - Emily - George - Henry - Luis - Oliver  
Available for models:  
Allen - Scotty - Edgar - Emily - George - Henry - Luis - Oliver  
Disponibile pour les modèles:  
Allen - Scotty - Edgar - Emily - George - Henry - Luis - Oliver  
Für folgende Modelle erhältlich:  
Allen - Scotty - Edgar - Emily - George - Henry - Luis - Oliver

## Relax System

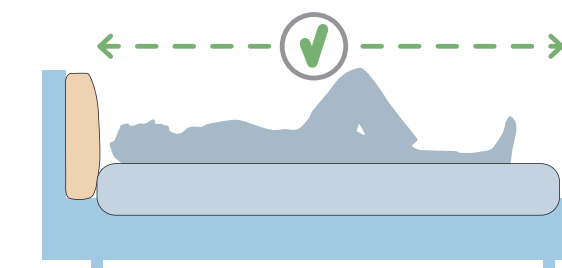

Tutta la lunghezza, tutto il materasso. Le nicchie non rubano spazio al materasso che rimane utilizzabile in tutta la sua lunghezza.

All the length, all the mattress. The niches do not take mattress space that can still be used throughout its length.

Toute la longueur, tout le matelas. Les niches ne volent pas de place au matelas qui peut être utilisé sur toute la longueur.

Volle Länge, die gesamte Matratze. Die Nischen nehmen der Matratze keinen Platz weg, die über ihre gesamte Länge nutzbar bleibt.

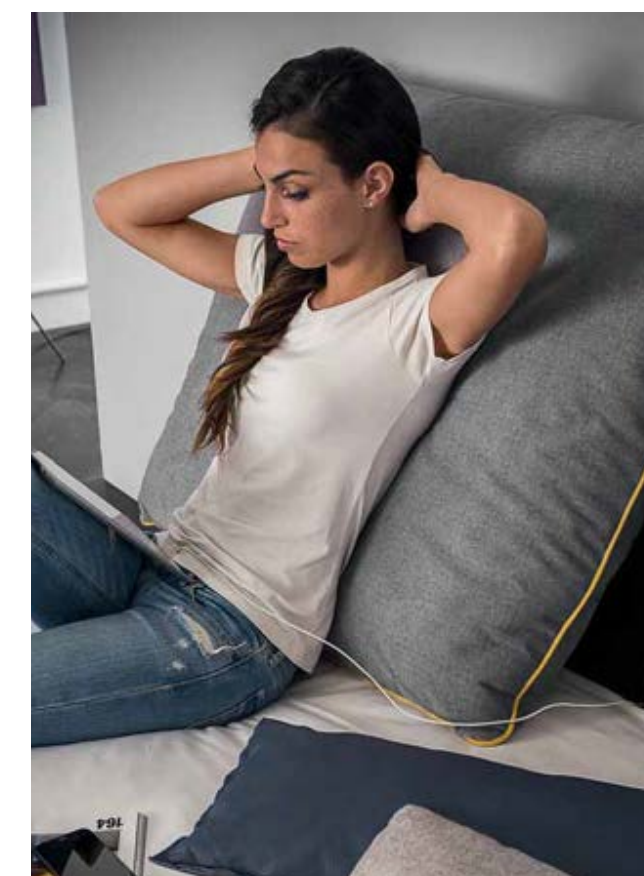
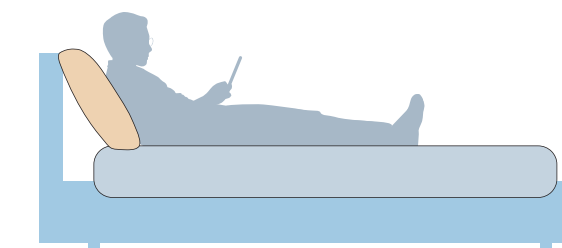

## USB carica batterie

USB battery charger  
USB chargeurs batterie  
USB-BATTERIELADEGERÄT

Disponibile per i modelli: Allen - Scotty - Edgar - Emily - George - Henry - Luis - Oliver  
Available for models: Allen - Scotty - Edgar - Emily - George - Henry - Luis - Oliver  
Disponibile pour les modèles: Allen - Scotty - Edgar - Emily - George - Henry - Luis - Oliver  
Für folgende Modelle erhältlich: Allen - Scotty - Edgar - Emily - George - Henry - Luis - Oliver

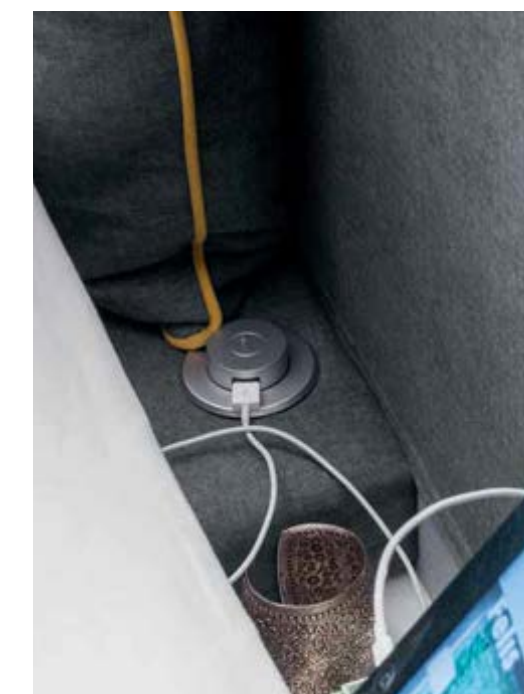

Le comode nicchie poi sono attrezzabili anche con una praticissima torretta caricabatteria per il telefono, il tablet, il personal computer... Comoda, non ingombrante, esce se serve solo con una leggera pressione e una volta utilizzata scompare.

The comfortable niches can then be equipped with a handy turret charger for your phone, tablet, personal computer... Convenient, unobtrusive, it exits, if needed, only by a little pressure and once used it disappears.

Les niches peuvent être aménagées avec une tourette pour recharger le téléphone, la tablette, l'ordinateur portable... Pratique et non encombrante elle sort seulement en cas de besoin, une légère pression pour la faire sortir et une fois utilisée elle disparaît.

Die bequemen Nischen können auch mit einem praktischen Ladegerät für Ihr Handy, Tablet oder Ihren PC ausgestattet werden. Das bequeme und nicht sperrige Ladegerät lässt sich bei Bedarf mit leichtem Druck herausnehmen und verschwindet nach Gebrauch wieder.

## Piedi

### SIXTY - H 21 cm



**Ottone** / Brass  
/ Laiton / Messing

**Carbon look**



**Rame** / Copper  
/ Cuivre / Kupfer

**Cromo** / Chrome  
/ Chrome / Chrom

Piedini conici in metallo verniciati con polveri epossidiche.  
Metal conical feet powder coated.  
Petits pieds coniques en métal vernis aux poudres époxydes.  
Konische Metallfüße mit Epoxid-Pulverbeschichtung.

### CHOKO - H 21 cm



**Ciocolato** / Chocolate  
/ Chocolat / Schokolade

Piedini in metallo a stiletto.  
Stiletto metal feet.  
Petits pieds à aiguille en métal.  
Stiletto-Füße aus Metall.

### CLOUD SYSTEM - H 21 cm



Piede in tubo rettangolare di metallo verniciato.  
Foot in painted metal rectangular pipe.  
Pied en tube rectangulaire de métal verni.  
Fuß aus lackiertem Vierkantröhr.

**Nero opaco** / Mat black  
/ Noir mat / Mattschwarz

### TWINNY - H 13 cm



**Cromo lucido** / Shining  
chrome / Chrome brillant  
/ Chrom Hochglanz



**Carbon look lucido** / Shining  
carbon look / Carbon look  
brillant / Carbon-Look  
Hochglanz



**Nero opaco** / Mat black  
Noir mat / Mattschwarz

Piedini in metallo a doppio stiletto.  
Double stiletto metal foot.  
Pieds en métal double talon.  
Doppel-Stiletto-Füße.

### PIEDE A SLITTA - H 13 cm



**Grigio Piombo** / Lead Grey  
/ Gris Plombe / Bleigrau

### BAOBAB - H 13 cm



**Rovere Londra** / Dak  
"Londra" / Chene "Londra"  
/ Eiche "Londra"



**Rovere tabacco** / Dak  
"tabacco" / Chene "tabacco"  
/ Eiche "tabacco"



**Rovere naturale** / Dak  
"naturale" / Chene "naturale"  
/ Eiche "naturale"

Piedini in legno naturale massiccio.  
Solid natural wood feet.  
Pieds de support en bois massif naturel.  
Füße aus massivem Naturholz.

## Piedi per ring a terra

Feet for ring on the ground / Pieds pour tour de lit au sol  
/ Fuesse für Bodenbettrahmen

### BASIC - H 3 cm



**Wengè** / Wengè  
/ Wengè / Wengè



**Bianco** / White  
/ Blanc / Bianco

Polipropilene rigenerato e riciclabile.  
Recycled and recyclable polypropylene.  
Polypropylène régénéré et recyclé.  
Regeneriertes und recycelbares Polypropylen.

### CLASSIC - H 5 cm



**Wengè** / Wengè  
/ Wengè / Wengè



**Argento** / Silver  
/ Argent / Silber

Faggio naturale stagionato, verniciato con tinte ad acqua.  
Aged natural beech, painted with water paint.  
Hêtre naturel vieilli, vernis avec vernis à eau.  
Abgelagertes Naturholz, Buche. Mit Farben auf Wasserbasis lackiert.

Standard



**Nero** / Black  
/ Noir / Schwarz



**Argento** / Silver  
/ Argent / Silber

### LUX - H 3 cm



**Wengè** / Wengè  
/ Wengè / Wengè



**Bianco** / White  
/ Blanc / Bianco

Piede ad "elle" composto di due pezzi per misure complessive cm 18 x 18. Faggio naturale stagionato. Verniciatura tinta: wengè, nero, bianco opaco e cromato.  
"L" feet composed of two pieces for total size 18 x 18. Aged natural beech. Paint colors: wenge, black, matt white and chrome.  
Pied en "L" composé de deux pièces pour une dimension totale de 18cm x 18. Hêtre naturel vieilli. Couleurs vernis: wengè, nero, bianco opaco et cromato.  
Aus zwei Teilen bestehender L-förmiger Fuß mit Gesamtmaß 18 x 18 cm. Abgelagertes Naturholz, Buche. In folgenden Farben lackiert: Wenge, Schwarz, Mattweiß und Chrom.

### VISUAL - H 9 cm



**Wengè** / Wengè  
/ Wengè / Wengè



**Bianco** / White  
/ Blanc / Bianco

Polipropilene rigenerato e riciclabile.  
Recycled and recyclable polypropylene.  
Polypropylène régénéré et recyclé.  
Regeneriertes und wiederverwertbares Polypropylen.

Optional



**Nero** / Black  
/ Noir / Schwarz



**Cromo** / Chrome  
/ Chrome / Chrom

Optional



**Nero** / Black  
/ Noir / Schwarz



**Argento** / Silver  
/ Argent / Silber

## Piedi per ring alti

Feet for high ring / Pieds pour cadres de lit hauts / Füße für hohe Bettgestelle

### BLADE - H 13 cm

Standard



**Satinato / Satin**  
/ Satiné / Satiniert

**Lega di alluminio pressofusa.**  
Verniciato con epossidica satinato con trattamento di spazzolatura.  
Die-cast aluminum. Painted with epoxy satin brushed.  
Alliage d'aluminium par pressofusion.  
Vernis époxy satiné brossé.  
Druckgegossene Alu-Legierung.  
Satinierter Epoxid-Pulverbeschichtung, gebürstet.



**Bronzato / Bronze**  
/ Bronze / Bronziert

**Lega di alluminio pressofusa.**  
Verniciato con epossidica bronzo con trattamento di spazzolatura.  
Die-cast aluminum. Painted with epoxy bronze brushed.  
Alliage d'aluminium par pressofusion.  
Vernis époxy bronze brossé.  
Druckgegossene Alu-Legierung.  
Satinierter Epoxid-Pulverbeschichtung, gebürstet.

### MOZART - H 9 cm

Optional



**Wengè / Wengè**  
/ Wengè / Wengè



**Argento / Silver**  
/ Argent / Silber

**Faggio naturale stagionato, verniciato con tinte ad acqua.**  
Aged natural beech, painted with water paint.  
Hêtre naturel vieilli, vernis avec vernis à eau.  
Abgelagertes Naturholz, Buche. Mit Farben auf Wasserbasis lackiert.



**Bianco / White**  
/ Blanc / Bianco



**Oro / Gold**  
/ Or / Gold

### TOWER - H 13 cm

Optional



**Acciaio cromato lucido.**  
Chrome plated steel.  
Acier chromé brillant.  
Stahl, hochglanzverchromt.

### PLEXY - H 13 cm

Optional



**Plexiglass trasparente con spessore 30mm e gommino antiscivolo.**  
Plexiglas with 30mm thickness and non-slip rubber.  
Plexiglas transparent épaisseur 30mm et caoutchouc anti-dérapant.  
30mm dickes transparentes Plexiglas mit rutschfestem Gummi.

## Reti

Supports  
Sommiers  
Bettenroste

Disponibile per i modelli:  
Taipei - Moonlight - Elle  
Available for models:  
Taipei - Moonlight - Elle  
Disponible pour les modèles:  
Taipei - Moonlight - Elle  
Für folgende Modelle erhältlich:  
Taipei - Moonlight - Elle

**Il pannello in multistrato di pioppo, utilizzato al posto della classica rete a doghe, è forato per consentire un corretto ricircolo dell'aria.**

The panel in poplar plywood, replacing the traditional slatted frame, is drilled to allow a proper air recycling.

Le panneau en multicouches de peuplier, utilisé à la place du sommier à lattes classique, est troué afin de permettre une circulation correcte de l'air.

Die Pappelmehrschichtholzplatte, die anstelle des klassischen Lattenrostes verwendet wird, weist Löcher auf, um eine gute Luftzirkulation zu ermöglichen.

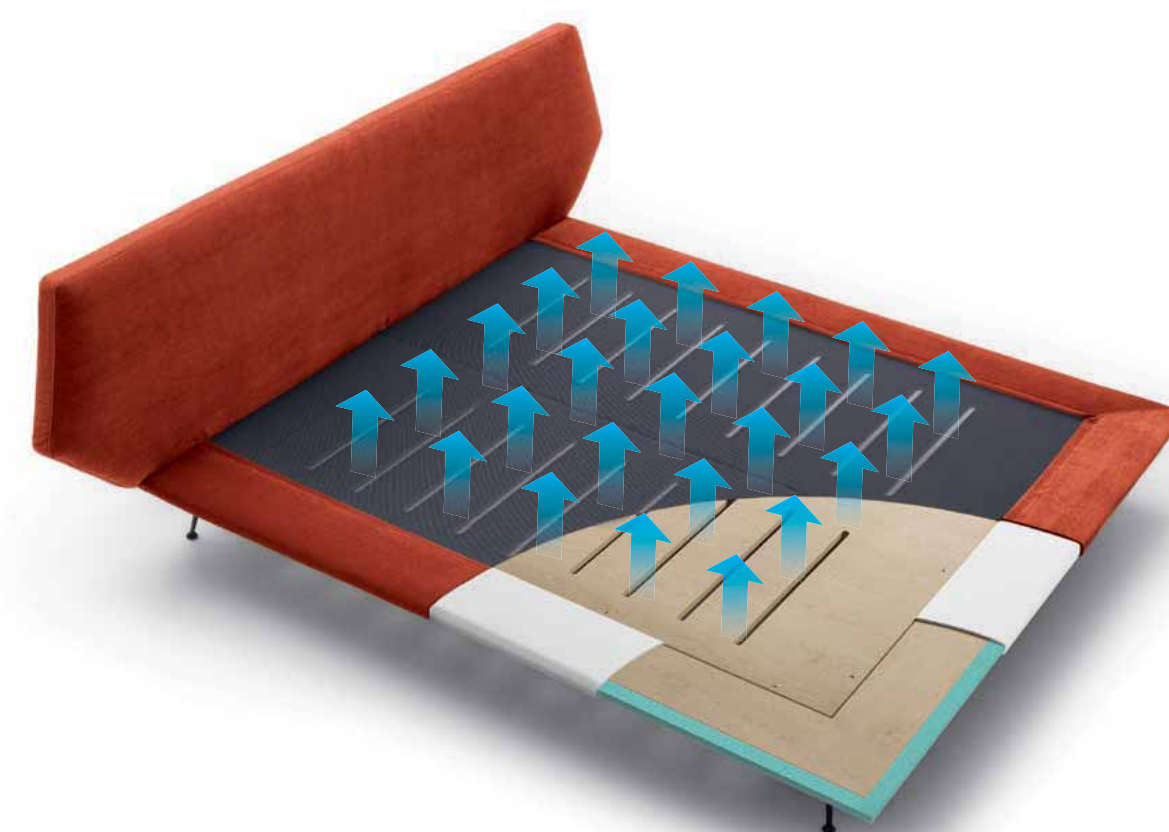

**VERSIONE RING IN TESSUTO TECNOLOGIA ANTISHOCK**  
VERSION WITH RING IN ANTISHOCK TECHNOLOGY FABRIC  
VERSION AVEC CADRE EN TISSU TECHNOLOGIE ANTI SHOCK  
BETTGESTELLVERSION AUS STOFF MIT ANTAUFPRALL-TECHNOLOGIE

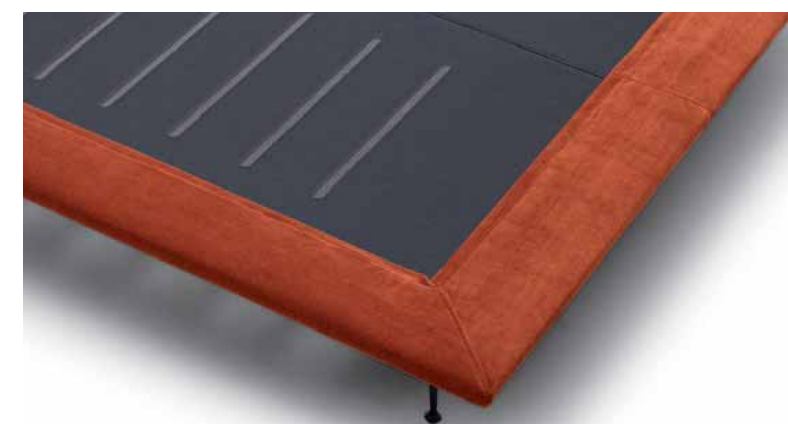

**VERSIONE CON RING IN LEGNO**  
VERSION WITH WOOD RING  
VERSION AVEC CADRE EN BOIS  
VERSION MIT BETTGESTELL AUS HOLZ



## Reti

Le reti sono a struttura metallica con doghe in faggio.  
Supports have a metal frame with beech slats.  
Les sommiers ont une structure métallique avec lattes en hêtre.  
Die Bettenroste weisen eine Metallstruktur mit Latten aus Buchenholz auf.

### 1. ARMONY

**1 - La rete Armony è attrezzata con doghe da 68 mm in multistrato di faggio evaporato e curvate a caldo a bassissimo rilascio di formaldeide: 13 doghe per la versione a 1 piazza e 26 doghe per la versione a 2 piazze. Sono solidali alla struttura metallica con attacchi in gomma siliconica. Il Telaio è in acciaio a sezione quadra 40mm x 30mm. Verniciatura con polveri epossidiche.**

1 - The Armony support is equipped with 68 mm beech plywood slats evaporated and hot curved with very low formaldehyde release: 13 slats for the single bed version and 26 slats for the double bed version. They are integrated with the metal structure with silicone rubber connections. The frame is steel with a 40mm x 30mm square section. Epoxy powder painted.

1 - Le sommier Armony a 68 lattes de 68mm en multicouches de hêtre évaporées et recourbées à chaud avec un taux de formaldéhyde très bas: 13 lattes pour la version 1 place et 26 lattes pour la version 2 places. Elles sont montées sur la structure métallique avec des pièces en silicone. Le cadre est en acier à section carrée 40x30mm Vernis epoxy.

1 - Der Armony-Bettenrost ist mit 68 mm breiten Latten aus mehrschichtigem, gedämpftem und warm gebogenem Buchenholz ausgestattet, das nur wenig Formaldehyd abgibt: 13 Latten für die Einzelbettversion und 26 Latten für die Doppelbettversion. Die Latten sind mit Silikonkautschukverbindungen an der Metallstruktur befestigt. Der Rahmen ist aus 40 mm x 30 mm starkem Vierkantstahl gefertigt. Epoxid-Pulverbeschichtung.

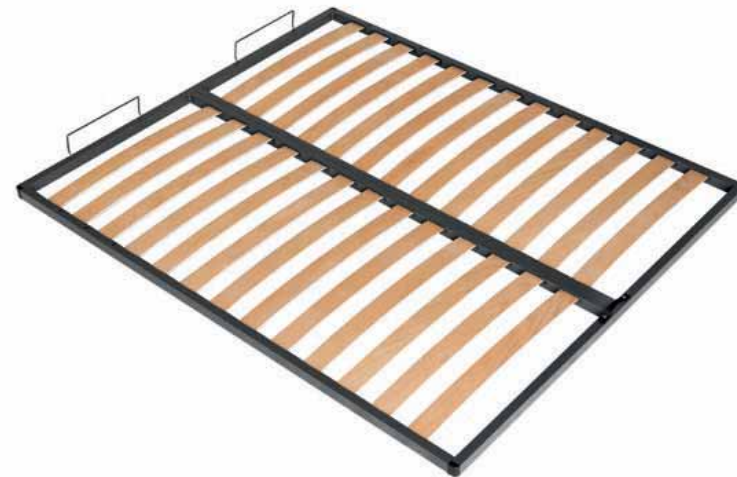

### 2. THAI

**2 - La rete Thai è attrezzata con doghe più numerose e sottili, per adattarsi maggiormente al peso specifico dell'utilizzatore e distribuire in modo uniforme la pressione del materasso. Le doghe sono da 38 mm in legno di faggio: 23 doghe per la versione a 1 piazza e 46 doghe per la versione a 2 piazze. Sono solidali alla struttura metallica grazie ad attacchi in gomma siliconica. Il Telaio è in acciaio a sezione quadra 40mm x 30mm. Verniciatura con polveri epossidiche.**

2 - The Thai support is equipped with more numerous and thinner slats, to fit better to the specific weight of the user and evenly distribute the pressure of the mattress. The 38 mm slats are made of beech: 13 slats for the single bed version and 26 slats for the double bed version. They are integrated with the metal structure with silicone rubber connections. The frame is steel with a 40mm x 30mm square section. Epoxy powder painted.

2 - Le sommier Thai a plus de lattes et elles sont plus fines, pour s'adapter plus facilement au poids de l'utilisateur et distribuer de manière uniforme la pression du matelas. Les lattes sont de 30mm en hêtre: 23 lattes pour la version 1 place et 46 pour la version 2 places. Elles sont montées sur la structure métallique avec des pièces en silicone. Le cadre est en acier à section carrée 40x30mm Vernis epoxy.

2 - Das Bettenrostmodell Thai ist mit mehreren und schmaleren Latten ausgerüstet, die sich besser an spezifische Gewicht des Benutzers anpassen und den Druck der Matratze gleichmäßig verteilen. Die Latten aus Buchenholz sind 38 mm breit: 23 Latten für die Einzelbettversion und 46 Latten für die Doppelbettversion. Die Latten sind mit Silikonkautschukverbindungen an der Metallstruktur befestigt. Der Rahmen ist aus 40 mm x 30 mm starkem Vierkantstahl gefertigt. Epoxid-Pulverbeschichtung.

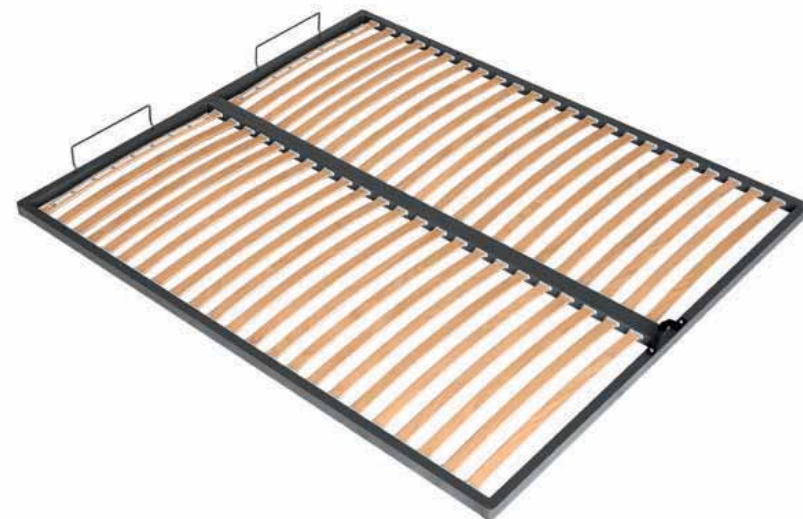

## / Supports / Sommiers / Bettenroste

### 3. ENERGY

**3 - La rete Energy è dotata di 6/12 doghe in più e relativi regolatori che consentono di variare la rigidità del piano di appoggio, nella zona lombare o dove si preferisce. Agendo sugli appositi regolatori di rigidità nelle zone prescelte e posizionandoli opportunamente è possibile definire esattamente la flessibilità delle diverse zone piano e personalizzare al massimo il sostegno della rete. Le doghe sono da 38 mm in multistrato di faggio evaporato e curvate a caldo a bassissimo rilascio di formaldeide: 23 doghe (+ 6 regolabili) per la versione a 1 piazza e 46 doghe (+ 12 regolabili) per la versione a 2 piazze. Sono solidali alla struttura metallica grazie ad attacchi in gomma siliconica. Il Telaio è in acciaio a sezione quadra 40mm x 30mm. Verniciatura con polveri epossidiche.**

3 - The Energy support is equipped with 6/12 more slats and corresponding adjusters that allow to vary the stiffness of the support surface, in the lumbar area or wherever you prefer. By moving the stiffness adjusters in select areas and placing them appropriately, it is possible to define precisely the flexibility of the different areas and personalize the support. The 38 mm slats are made with beech plywood slats evaporated and hot curved with very low formaldehyde release: 23 slats (+ 6 adjustable ones) for the single bed version and 46 slats (+ 12 adjustable ones) for the double bed version. They are integrated with the metal structure with silicone rubber connections. The frame is steel with a 40mm x 30mm square section. Epoxy powder painted.

3 - Le sommier Energy a 6/12 lattes en plus et des régulateurs qui permettent de varier la rigidité du plan d'appui sur la zone lombaire ou sur d'autres zones. En actionnant les régulateurs de rigidité dans les zones choisies et en les plaçant correctement il est possible de définir exactement la flexibilité des différentes zones et personnaliser au maximum le soutien du sommier. Les lattes de 38 mm en multicouches de hêtre évaporées et recourbées à chaud avec un taux de formaldéhyde très bas: 23 lattes pour la version 1 place (+ 6 réglables) et 46 lattes (+ 12 réglables) pour la version 2 places. Elles sont montées sur la structure métallique avec des pièces en silicone. Le cadre est en acier à section carrée 40x30mm Vernis epoxy.

3 - Das Bettenrostmodell Energy ist mit 6/12 weiteren Latten und relativen Verstellmöglichkeiten ausgerüstet, die es Ihnen ermöglichen, die Steifigkeit der Liegefläche zu variieren, im Lendenbereich oder wo immer Sie es wünschen. Durch eine entsprechende Positionierung der Steifigkeitsversteller in den ausgewählten Bereichen ist es möglich, die Flexibilität der verschiedenen Liegeflächenbereiche genau festzulegen und das Stützvermögen des Bettenrostes so weit wie möglich individuell anzupassen. Die 38 mm breiten Latten sind aus mehrschichtigem, gedämpftem und warm gebogenem Buchenholz, das nur wenig Formaldehyd abgibt: 23 (+ 6 verstellbare) Latten für die Einzelbettversion und 46 (+12) Latten für die Doppelbettversion. Die Latten sind mit Silikonkautschukverbindungen an der Metallstruktur befestigt. Der Rahmen ist aus 40 mm x 30 mm starkem Vierkantstahl gefertigt. Epoxid-Pulverbeschichtung.



### Doppio Flip

**Rete DOPPIO FLIP su richiesta. Disponibile nella versione 140/160x190/200 - 180x200.**

DUAL FLIP slatted frame optional on request. Available in 140/160x190/200 - 180x200.

Sommier DOPPIO FLIP en option sur demande. Disponible dans la version 140/160x190/200 - 180x200.

Lattenrostmodell optional DOPPIO FLIP ist nach Anfrage nur in den Größen 140/160x190/200-180x200 verfügbar.

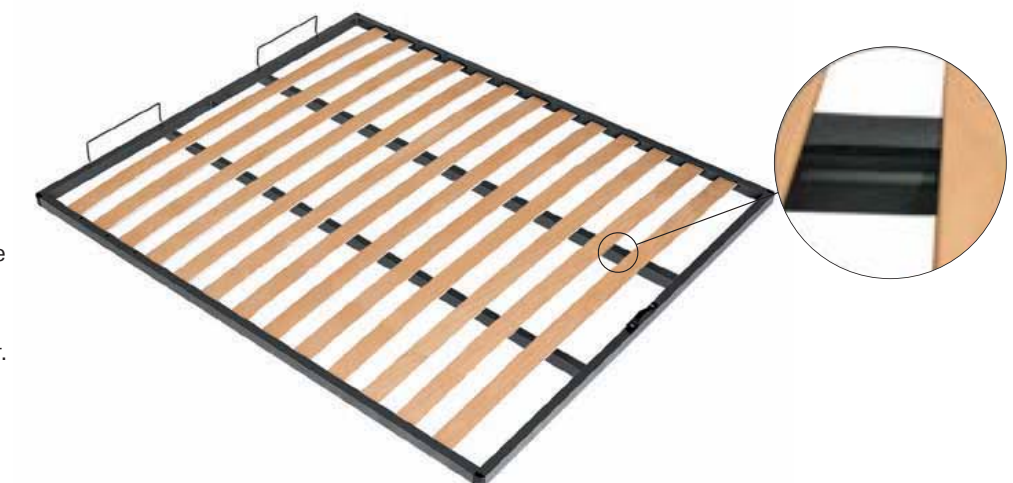

# Meccanismi

Mechanisms  
Mécánismes  
Mechanismen

**Il piano-rete si alza facilmente e senza sforzo grazie ai 2 meccanismi sicuri, brevettati e certificati. È facile veloce e pratico sollevare il materasso e avere accesso ai capaci contenitori. Il meccanismo tradizionale (A.), consente il sollevamento a 45°. Il secondo (B.), sempre servo assistito, consente sia il sollevamento a 45° sia il successivo sollevamento di rete e materasso parallelamente al pavimento all'altezza di 1 mt. In questo modo si avrà un accesso più diretto ai contenitori e si lavorerà più comodamente per rifare il letto, senza doversi abbassare.**

The support can be lifted and effortlessly thanks to two safe mechanisms, patented and certified. To lift the whole bed and access the capable containers is easy, fast and convenient. The traditional mechanism (A.) tested and certified up to 5,000 cycles, enables lifting up to 45°. The second (B.), always power assisted, allows both lifting at 45° and lifting of support and bed parallel to the floor up to the necessary height (h 1 m). To have a more complete access to the containers and to work more comfortably and make the bed without having to bend down in awkward positions and lift the mattress from below.

Le sommier se soulève aisément sans effort grâce aux 2 mécanismes sûrs, brevetés et certifiés. Le levage du matelas pour avoir accès aux conteneurs est facile, rapide et pratique. Le mécanisme traditionnel (A), permet le levage à 45°. Le deuxième (B), toujours assisté, permet tant le levage à 45° que le successif levage du sommier et matelas parallèlement au sol à la hauteur d'1 mt. De cette façon on pourra accéder directement ax conteneurs en travaillant plus facilement pour faire le lit, sans se baisser.

Die Liegefläche - der Bettenrost kann dank 2 sicherer, patentierter und zertifizierter Mechanismen leicht und mühelos angehoben werden. Die Matratze lässt sich einfach anheben und der schnelle Zugang zu den großen Stauräumen ist äußerst praktisch. Der traditionelle Mechanismus (A.) ermöglicht das Anheben in einem Winkel von 45°. Der zweite Mechanismus (B.), ebenfalls mit Servounterstützung, ermöglicht sowohl das Anheben um 45° als auch das anschließende Anheben von Bettenrost und Matratze parallel zum Boden in einer Höhe von 1 m. Auf diese Weise haben Sie einen noch direkteren Zugriff auf die Bettkästen und das Bettenmachen fällt wesentlich bequemer aus, ohne sich bücken zu müssen.

## A. Dynamic

**Meccanica ad "alzata semplice" collaudata e certificata fino a 5.000 cicli. Telaio in acciaio verniciato a polveri epossidiche e con molle a gas tarate al peso del materasso.**

Simple lift-up mechanics calibrated and certified up to 5,000 cycles. Powder coated steel frame with gas springs set on mattress weight.

Mécanique à "levée simple" testée et certifiée jusqu'à 5000 cycles. Structure en acier vernie aux poudres époxydes et avec ressorts à gaz calibrés selon le poids du matelas.

Einfacher Hubmechanismus, getestet und zertifiziert für bis zu 5.000 Zyklen. Mit Epoxidpulver lackierter Stahlrahmen und Gasdruckfedern, die auf das Gewicht der Matratze abgestimmt sind.



Vano utile H 18 cm  
Practical compartment, H 18 cm deep  
Compartment utile de H 18 cm  
Stauraum H 18 cm



Vano utile H 12 cm  
Practical compartment, H 12 cm deep  
Compartment utile de H 12 cm  
Stauraum H 12 cm

## B. Maverick

**Meccanica "a doppia alzata" collaudata fino a 4.000 cicli sia per funzione contenitore che per funzione rifacimento letto. Telaio in acciaio verniciato a polvere epossidiche e con molle a gas tarate al peso del materasso.**

"Double lift" mechanism tested up to 4,000 cycles for both the container function and the bed-making. Steel frame coated with epoxy powder paint and with gas springs calibrated to the weight of the mattress bed making.

Mécanique à double soulèvement testé jusqu'à 4.000 cycles pour la fonction de rangement et la fonction lit relevé. Le cadre en acier vernis epoxy et avec ressorts pneumatiques réglés pour le poids du matelas refaire le lit.

„Doppelhub“-Mechanismus, für bis zu 4.000 Zyklen getestet, sowohl was die Bettkasten- als auch die Bettenmachfunktion angeht. Mit Epoxidpulver lackierter Stahlrahmen und Gasdruckfedern, die auf das Gewicht der Matratze abgestimmt sind.



Vano utile H 18 cm  
Practical compartment, H 18 cm deep  
Compartment utile de H 18 cm  
Stauraum H 18 cm



## Contentore nel ring

Container inside the ring  
Rangement dans le ring  
Bettkasten im Bettgestell

I contenitori all'interno del ring sono dotati di spazzolini antipolvere applicate sul bordo da 14 mm dei pannelli di fondo che sono dotati di comode maniglie per l'eventuale movimentazione.

The containers inside the ring are hermetically closed thanks to the dustproof brushes applied on the edge, 14 mm from the base panels which are equipped with comfortable handles for any movement.

Les rangements à l'intérieur du tour de lit sont fermés hermétiquement par des brosses anti-poussière appliquées sur le bord de 14mm des panneaux de fonds qui sont dotés de poignées pour un éventuel déplacement.

Die im Inneren des Bettgestells untergebrachten Stauräume sind mit Staubbürsten ausgestattet, die an der 14mm-Kante der Bodenplatten angebracht sind, die mit praktischen Griffen für ein eventuelles Umsetzen ausgestattet sind.



Vano utile H 18 cm.  
Practical compartment, H 18 cm deep.

Compartment utile de H 18 cm.  
Stauraum H 18 cm.

Per lunghezza / by length / par longueur / bei einer Länge von 190 cm

larghezza / width / largeur / Breite cm	90	120	140	160	180	200
litri / liters / litres / Liter	350	460	530	600	670	740



Vano utile H 12 cm.  
Practical compartment, H 12 cm deep.

Compartment utile de H 12 cm.  
Stauraum H 12 cm.

Per lunghezza / by length / par longueur / bei einer Länge von 200 cm

larghezza / width / largeur / Breite cm	90	120	140	160	180	200
litri / liters / litres / Liter	350	460	530	600	670	800

## Sacca contenitore: protezione dalla polvere

Bag container: protection from dust  
Sac coffre de rangement: protection contre la poussière  
Aufbewahrungstasche: als Staubschutz

Contentore con sacca: per riporre, proteggere e contenere ordinatamente la tua biancheria, le coperte, i guanciali. Le ampie sacche con la comoda ermetica apertura a cerniera doppia zip, per la più pratica accessibilità, consentono il massimo di igiene e pulizia.

Rangement avec sac: pour ranger, protéger et contenir d'une manière ordonné le linge de maison, les couvertures, les oreillers. Les grands sacs avec une fermeture hermétique à fermeture éclair sont un petit détail. Mais une grande idée pour l'hygiène et le nettoyage.

Container with bag: to neatly store, protect and contain your underwear, blankets, pillows. The large bags with the convenient hermetic zip opening are a little ingenuity. But a great idea for maximum hygiene and cleanliness.

Bettkasten mit Tasche: zur Aufbewahrung, zum Schutz und zur ordentlichen Unterbringung Ihrer Wäsche, Decken und Kopfkissen. Die großen Beutel, die sich dank des doppelten Reißverschlusses dicht verschließen lassen, gewährleisten maximale Hygiene und Sauberkeit.



## Coprirete

Support cover  
Couvre-sommier  
Bettenrostauflege



Guaina coprirete a prova di polvere in tessuto elastico. Crea una ulteriore barriera per proteggere i contenitori dalla polvere e il materasso dallo sfregamento delle doghe. Pratico, sano, efficiente.

Support cover dust-proof in stretchy fabric. Creates a further barrier to protect the containers from dust and the mattress from the rubbing of the slats. Practical, healthy, efficient.

Gaine couvre-sommier contre la poussière en tissu élastique. Elle crée une ultérieure barrière pour protéger les coffres de rangement de la poussière et le matelas du frottement des lattes. Pratique, sain, efficace.

Vor Staub schützende Bettenrostauflege aus einem elastischen Gewebe. Schafft eine zusätzliche Barriere, um die Stauräume vor Staub und die Matratze vor Reibung an den Latten zu schützen. Praktisch, gesund, effizient.



Disponibile per tutti i modelli.  
Available for all models.  
Disponible pour tous les modèles.  
Für alle Modelle erhältlich.

## Tavolino

Table  
Table basse  
Beistelltisch



I tavolini in metallo curvato e verniciato grigio piombo sono inseribili nel ring di tutta la nostra collezione letti. Possono diventare comodini, panche e sedute a seconda delle esigenze. Più funzioni con design leggero e versatile.

Curved, lead-grey painted metal table, which can be attached to all of the bed frames in our collection. They can be used as bedside tables, benches or seats according to need. Multiple functions, with a light and versatile design.

Tables basses en métal arrondi et verni grigio piombo pouvant être insérées dans toute notre collection lits. Elles peuvent devenir des tables de chevet, des banquettes et des sièges selon les exigences. Plusieurs fonctions avec un design léger et versatile.

Die Beistelltische aus gebogenem und in Blaugrau lackiertem Metall können ins Gestell aller in unserer Kollektion befindlichen Betten eingefügt werden. Sie können je nach Bedarf zum Nachttisch, zur Sitzbank bzw. Sitzgelegenheit werden. Mehrere Funktionen bei einem leichten und vielseitigen Design.

## Cuscino per tavolino

Table seat cushion  
Coussin pour table basse  
Kissen für Beistelltisch



A richiesta sono disponibili i cuscini seduta tubolari come in foto. Realizzabili con tutti i tessuti della nostra collezione.

Specifically designed cushions are available on request to use the unit as a seat. They come in all of the fabrics in our collection.

Des coussins sur mesure sont également disponibles sur demande pour l'utilisation en siège. Réalisables dans tous les tissus de notre collection.

Nach Anfrage sind die auf dem Fotokatalog sichtbare schlauchförmige Sitzkissen verfügbar. Der Bezug des Kissen kann von allen Stoffen unserer Kollektion ausgewählt werden.

# Clean Up System per letti con contenitore

Clean Up System for bed with storage  
 Clean Up System pour lit avec coffre de rangement  
 Clean Up System für Betten mit Bettkasten

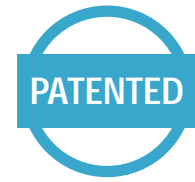

**Una nuova pratica soluzione per la pulizia sotto il letto, comodamente con swiffer, robotino, aspirapolvere. Per sollevare semplicemente il letto di 13 cm senza sforzo è sufficiente alzare due leve a scomparsa, sui lati del ring. In questo modo si abbassano 4 robuste ruote gommate antitraccia e si alza così tutto il letto che può essere anche spostato avanti e indietro senza sforzo. Quando le leve si abbassano, le ruote si sollevano e scompaiono e il letto poggia nuovamente sui suoi piedini. Facile, veloce, pratico e sicuro.**

A new practical solution for cleaning under the bed, comfortably with Swiffer, robot vacuum, vacuum cleaner. To raise the bed by 13 cm effortlessly, simply raise two retractable levers, on the sides of the ring. This way, the 4 robust non-marking rubber wheels are lowered all the bed is lifted, which can also be moved back and forth without effort. When the levers are lowered, the wheels are lifted and disappear and the bed rests on its feet again. Easy, fast, convenient, and safe.

Une nouvelle solution pour le nettoyage sous le lit, très pratique avec swiffer, robot aspirateur, aspirateur. Pour soulever simplement le lit de 13 cm sans effort il suffit de lever les deux leviers sur les côtés du tour de lit. De cette manière les 4 roues en caoutchouc anti-trace se baissent, le lit se lève et peut être déplacé sans aucun effort. Quand les leviers se baissent, les roues se soulèvent et disparaissent, le lit repose de nouveau sur ses pieds. Facile, rapide, pratique et sûr.

Eine neue, praktische Lösung für die Reinigung unter dem Bett, die bequem per Swiffer, Saugroboter oder Staubsauger erfolgen kann. Um das Bett mühelos um 13 cm anzuheben, heben Sie einfach die beiden versenkbaren Hebel an, die sich seitlich am Bettgestell befinden. Dieser Vorgang senkt 4 robuste, spurlose Gummiräder ab und hebt das gesamte Bett an, das sich dann darüber hinaus mühelos hin- und herbewegen lässt. Beim Absenken der Hebel heben sich die Räder an und verschwinden wieder, sodass das Bett erneut wieder auf seinen Füßen steht. Leicht, schnell, praktisch und sicher.

Disponibile solo per ring a terra H. 34 / Only available for floor-standing bed frame H. 34 / Disponible uniquement pour cadre de lit à poser au sol H. 34 / Nur für auf dem Boden ruhende Bettgestelle H. 34

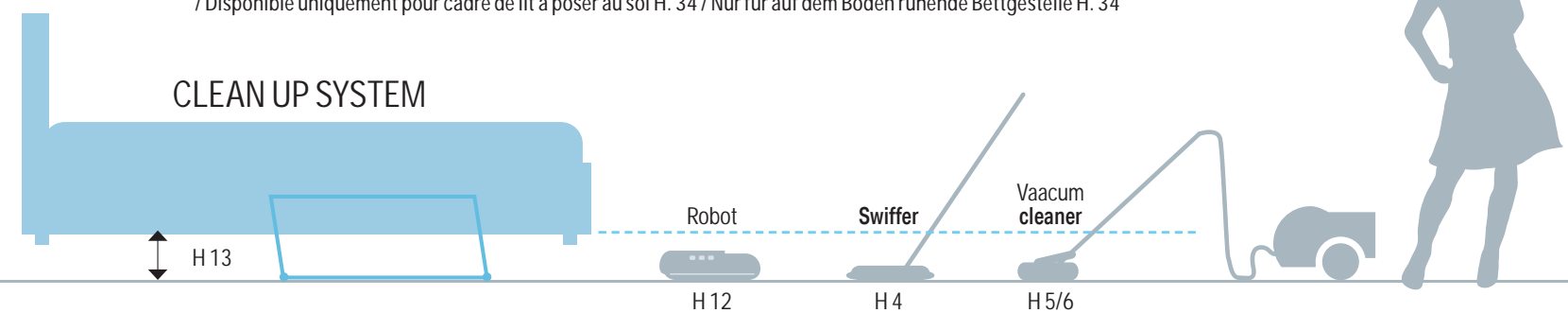

# Sempre l'altezza giusta

Always the right height  
 Toujours la bonne hauteur  
 Immer die richtige Höhe

**Angolare regolabile per sostegno rete:**  
 - per livellare alla stessa altezza due reti diverse nello stesso letto  
 - per regolare l'altezza del piano rete con lo spessore del materasso scelto  
 - o semplicemente per personalizzare e decidere l'altezza del materasso nel proprio letto.  
 Disponibili come optional in due versioni su tutti i modelli con rete senza meccanica.

A frankeable angle for the right support:  
 - to level two different supports at the same height in the same bed  
 - to ad franke the height of the support with the thickness of the chosen mattress  
 - or simply to customize and choose the height of the mattress of the bed.  
 Optionally available in two versions on all models without mechanic system.

Angle réglable pour soutenir le sommier:  
 - pour mettre à niveau la hauteur de deux sommiers différents dans un même lit  
 - pour régler la hauteur de la base de sommier avec l'épaisseur du matelas choisie  
 - ou simplement pour ersonnaliser et décider la hauteur du matelas dans le lit.  
 Disponibles en options en deux versions sur tous les modèles sans mécanique.

Verstellbares Winkelstück zum Abstützen des Bettenrosts:  
 - zum Nivellieren von zwei verschiedenen Bettenrosten auf die gleiche Höhe im selben Bett  
 - zum Anpassen der Bettenrosthöhe mit der Stärke der gewählten Matratze  
 - oder einfach nur zum Anpassen der Höhe der Matratze im eigenen Bett.  
 Erhältlich als Option in zwei Versionen für alle Modelle mit Bettenrost ohne Mechanik.

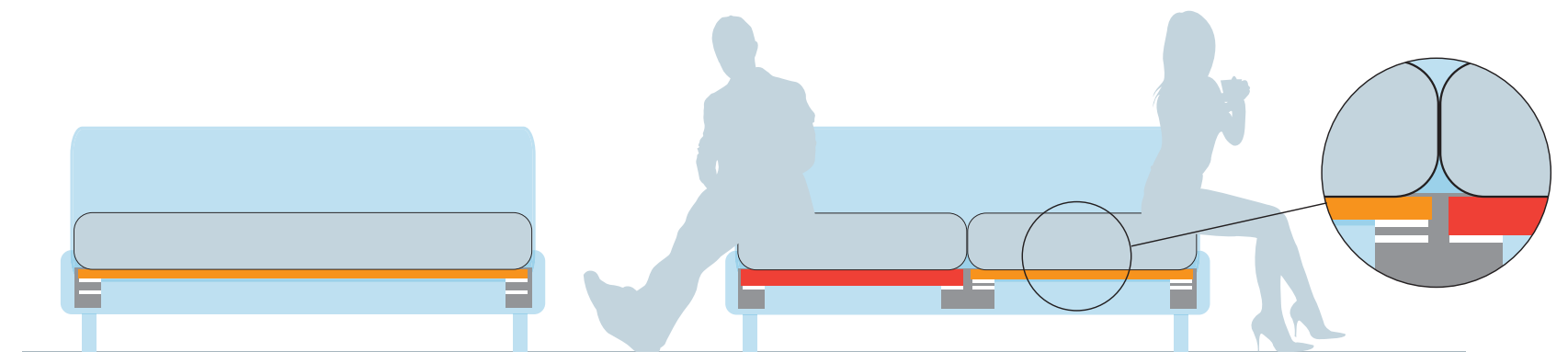

**RING ALTI / HIGH RINGS**  
 / CADRES DE LIT HAUTS / HOHE BETTGESTELLE

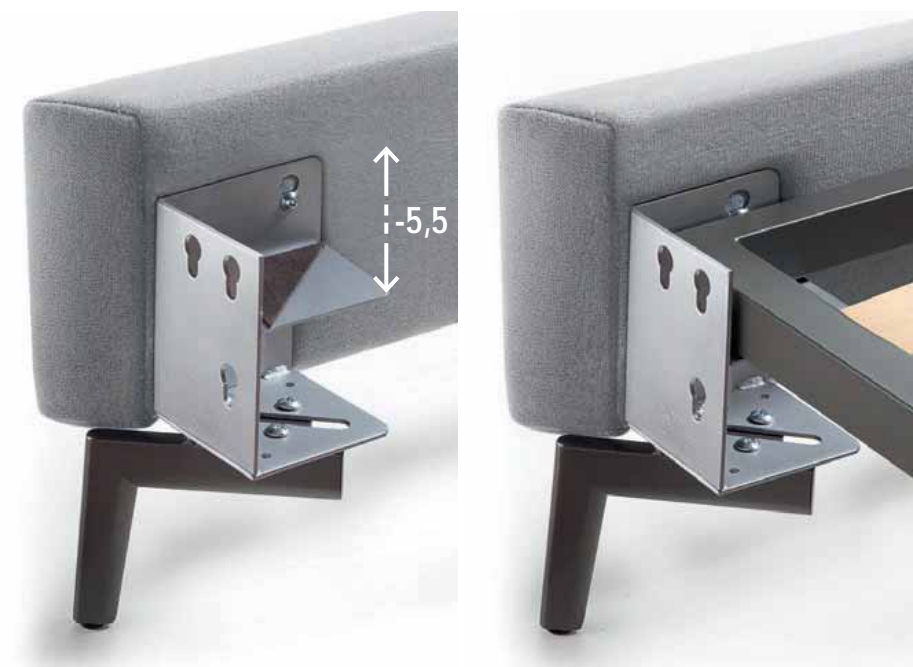

**RING BASSI / LOW RINGS**  
 / CADRES DE LITS BAS / NIEDRIGE BETTGESTELLE

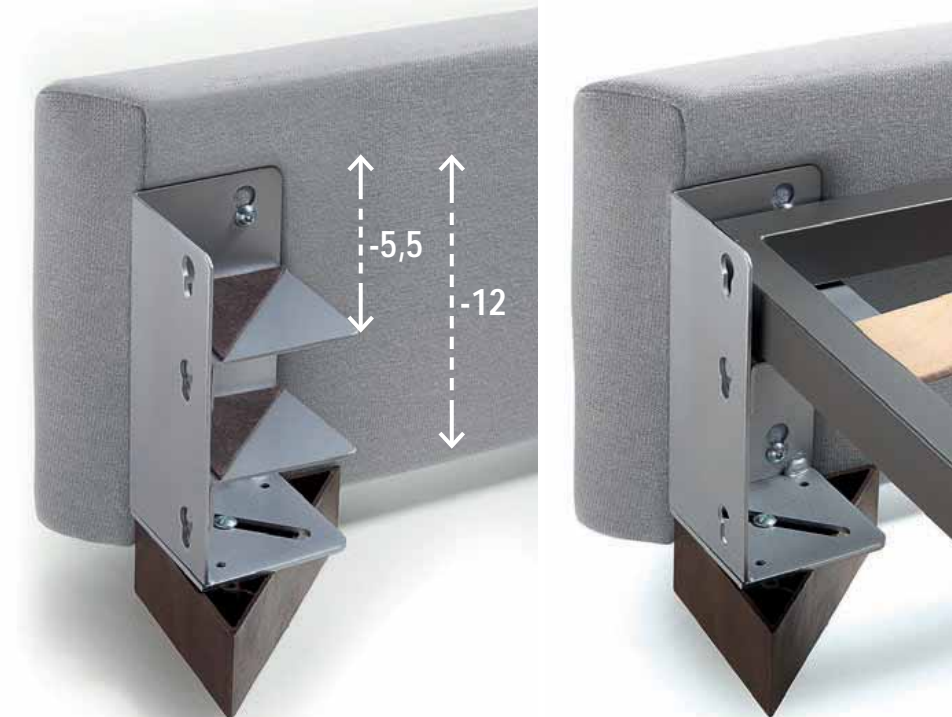





1990 YEARS 2020

**MADE IN ITALY**



art direction  
Gianluca Marcon

research and design  
Felis Lab

graphic design  
Luca Busetto

styling  
Federica Baro

color separation  
Bieffe

print  
Eurotipo

**felis**  
SOFT LIVING

FELIS SRL UNIPERSONALE

Via Pietro Zorutti, 22  
33074 Fontanafredda (PN) Italy

tel. +39 0434 737052  
fax +39 0434 737024

info@felis.it

www.felis.it

Seguici su



FELIS si riserva in qualsiasi momento la facoltà di apportare tutte le modifiche necessarie al miglioramento funzionale e qualitativo dei propri prodotti. Per ogni aspetto tecnico e dimensionale fare riferimento ai listini aziendali e relativi aggiornamenti. I colori e i materiali riprodotti nelle immagini hanno un valore indicativo.  
FELIS — ©

FELIS reserves the right to make all alterations necessary in order to improve the function and quality of its products at any time. For all technical matters and sizes, please refer to company price lists and relevant updates. The colours and materials reproduced in the pictures are purely indicative.  
FELIS — ©

FELIS se réserve en quelque moment la faculté d'apporter toutes les modifications nécessaires à l'amélioration fonctionnelle et qualitative des propres produits. Pour chaque aspect technique et de dimensions faire référence aux catalogues de la société et aux relatives mises à jour. Les couleurs et les matériaux représentés dans les images ont une valeur purement indicative.  
FELIS — ©

FELIS behält sich das Recht vor, jederzeit Änderungen vorzunehmen, die zur Verbesserung der Funktionalität und Qualität seiner Produkte notwendig sind. Für alle technischen und die Abmessungen betreffenden Aspekte verweisen wir auf die betrieblichen Preislisten und deren Aktualisierungen. Die auf den Bildern dargestellten Farben und Materialien haben reinen Beispielscharakter.  
FELIS — ©

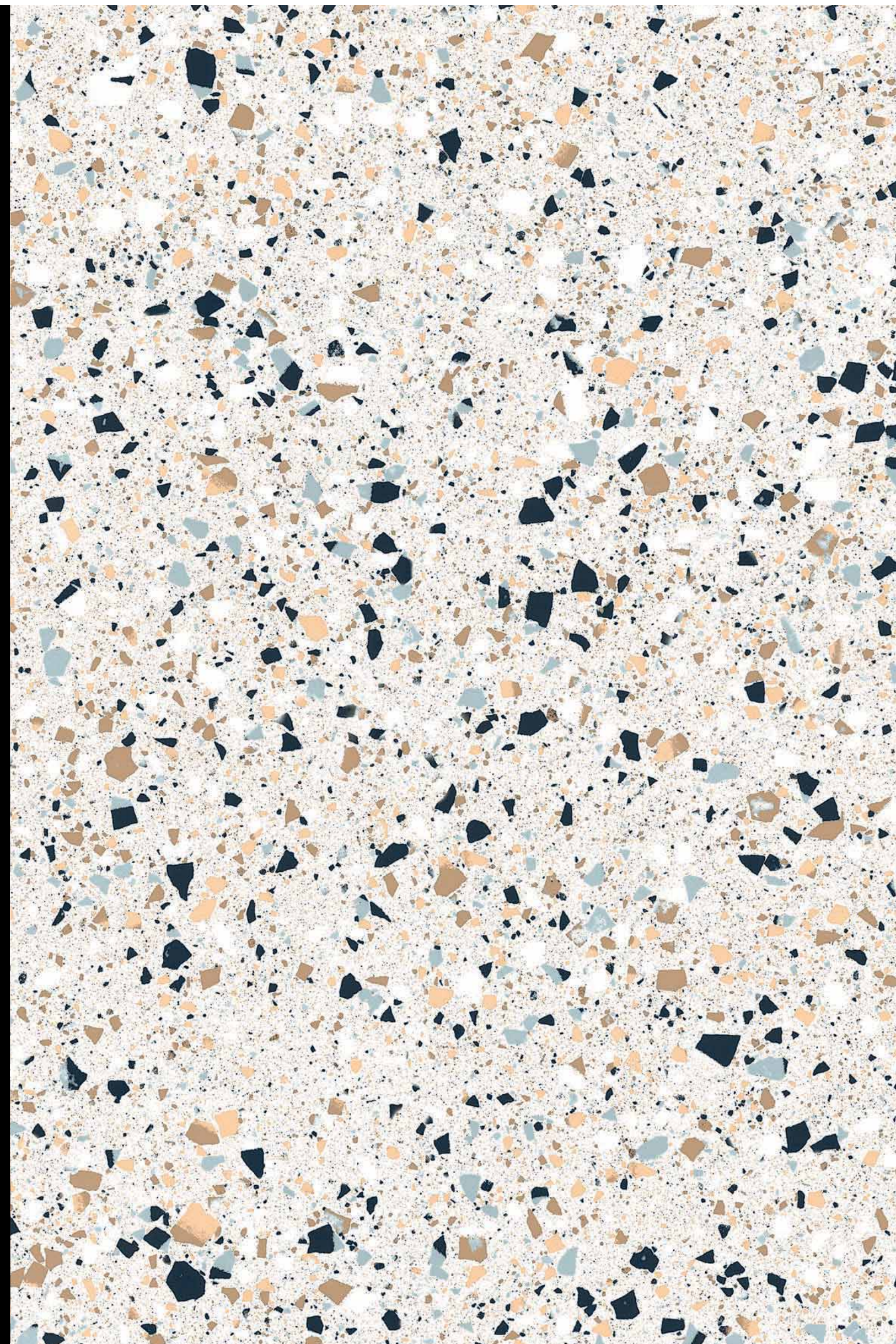



**felis**  
SOFT LIVING